

CONFIDENTIAL  
**UNCLASSIFIED**

**ARROW 1 SERVICE DATA**

SECTION 43

**ELECTRONICS**

**UHF HOMER ADAPTOR**

**AN/ARA-25**

(This data supersedes previous issue dated 25 June 57)

1 JUN 58

CONFIDENTIAL

ARROW 1 SERVICE DATA  
LIST OF REVISIONS

DATE

PAGE NO.

DATE

PAGE NO.

ARROW 1 SERVICE DATA

REVISIONS

# ARROW 1 SERVICE DATA

## ELECTRONICS

### UHF HOMER ADAPTOR AN/ARA-25

#### TABLE OF CONTENTS

TITLE	PAGE
SYSTEM SERVICE DATA	
DESCRIPTION	
General .....	1
Solenoid Relay RE-120/ARA-25 .....	1
UHF Homer Antenna AS-578A/ARA-25 .....	1
Electronic Control Amplifier AM-608/ARA-25 .....	1
Course Indicators(Dual) RMI Type ID-250/ARN .....	4
System Power Requirements .....	4
INSPECTION                    (To be issued later)	
FUNCTION TESTING	
General .....	4
Preparation for Testing .....	4
Function Testing Procedure .....	4
REMOVAL AND INSTALLATION	
General .....	5
Electronic Control Amplifier - Removal .....	5
Electronic Control Amplifier - Installation .....	6
Solenoid Relay - Removal .....	6
Solenoid Relay - Installation .....	6
UHF Homer Antenna - Removal .....	6
UHF Homer Antenna - Installation .....	6
Course Indicator - (Front Cockpit and Rear Cockpit) - Removal .....	6
Course Indicator - (Front Cockpit and Rear Cockpit) - Installation .....	6
EQUIPMENT LIST .....	9

ARROW 1 SERVICE DATA

UNCLASSIFIED

LIST OF ILLUSTRATIONS

FIGURE	TITLE	PAGE
1	UHF Homer Adaptor AN/ARA-25 - General Arrangement . . . . .	2
2	UHF Homer Adaptor AN/ARA-25 - Functional Block Diagram . . . . .	3
ROUTING DIAGRAM		
3	UHF Homer Adaptor AN/ARA-25 . . . . .	7

generator

electron  
motor

electron  
components

e-  
ce

## ARROW 1 SERVICE DATA

UNCLASSIFIED

## DESCRIPTION

## GENERAL

1 The UHF Homer Adaptor AN/ARA-25 is used in conjunction with the UHF Radio System AN/ARC-34 to obtain, for homing purposes, the bearing of the radio station to which the main receiver of the UHF Radio System is tuned. The bearing indication is displayed on Course Indicators (Dual) RMI Type ID-250/ARN. The operation of the adaptor is controlled from the UHF radio set control.

2 The UHF Homer Adaptor comprises the following main component units:

- (a) Solenoid Relay RE-120/ARA-25.
- (b) Solenoid Relay Mounting MT-1042/ARA-25.
- (c) UHF Homer Antenna AS-578A/ARA-25.
- (d) Electronic Control Amplifier AM-608/ARA-25.
- (e) Electronic Control Amplifier Mounting MT-1043/ARA-25.
- (f) Course Indicators (Dual) RMI Type ID-250/ARN (2).

## SOLENOID RELAY RE-120/ARA-25

3 Selecting the ADF position on the function switch, marked OFF-MAIN-BOTH-ADF, located on the UHF radio set control, energizes the solenoid relay. This action connects the UHF homer antenna to the UHF Radio Set AN/ARC-34 in lieu of the UHF antenna. A further action of the function switch in the ADF position is to energize a relay in the electronic control amplifier to complete the plate supply to this unit.

## UHF HOMER ANTENNA AS-578A/ARA-25

4 The UHF homer antenna receives signals in the 225 Mc/s to 399.9 Mc/s range and is automatically positioned by the electronic control amplifier to indicate the direction of the transmitting point.

5 The antenna comprises a directional receiving element, a 100 cps antenna switch, an antenna drive motor, a synchro generator and a rate generator.

6 The receiving element is rhombic shaped and, to obtain a cardioid field pattern and attain unidirectional properties, each end is grounded alternately through a terminating resistor. The termination, and consequently the field pattern, is switched from one end of the antenna to the other 100 times per second by the antenna switch. The antenna switch operates in synchronism with a vibrator circuit in the electronic control amplifier. The antenna is orientated by the antenna drive motor which is controlled by the electronic control amplifier.

ELECTRONIC CONTROL AMPLIFIER  
AM-608/ARA-25

7 The electronic control amplifier functions by positioning the UHF homer antenna correctly to indicate accurately the bearing of the transmitting point. The unit incorporates amplifier and filter circuits, a vibrator type synchronous rectifier circuit and a phase detecting motor control circuit.

8 When the UHF homer antenna is off bearing, the amplitude of signals appearing at opposite ends of the antenna will be unequal. The greater signal amplitude will appear at the end of the antenna nearer to the transmitting point. The difference in signal amplitudes will vary in relation to the angle by which the antenna is off bearing. The action of antenna switching will result in the received signals being modulated in the antenna with a 100 cps square wave-form proportional in amplitude to the angle by which the antenna is off bearing.

9 The square wave modulated signals are fed into the main receiver of the UHF Radio System. The signals are demodulated in the receiver and the 100 cps square wave containing audio components appears at the receiver output. These signals are fed to the electronic control amplifier where the audio components are filtered out. The resultant square wave is amplified and fed into the vibrator type synchronous rectifier circuit, where the square-wave voltage is rectified. The resultant voltage is fed through the phase sensitive motor control circuit to the field of the antenna drive motor.



ARROW 1 SERVICE DATA

UNCLASSIFIED

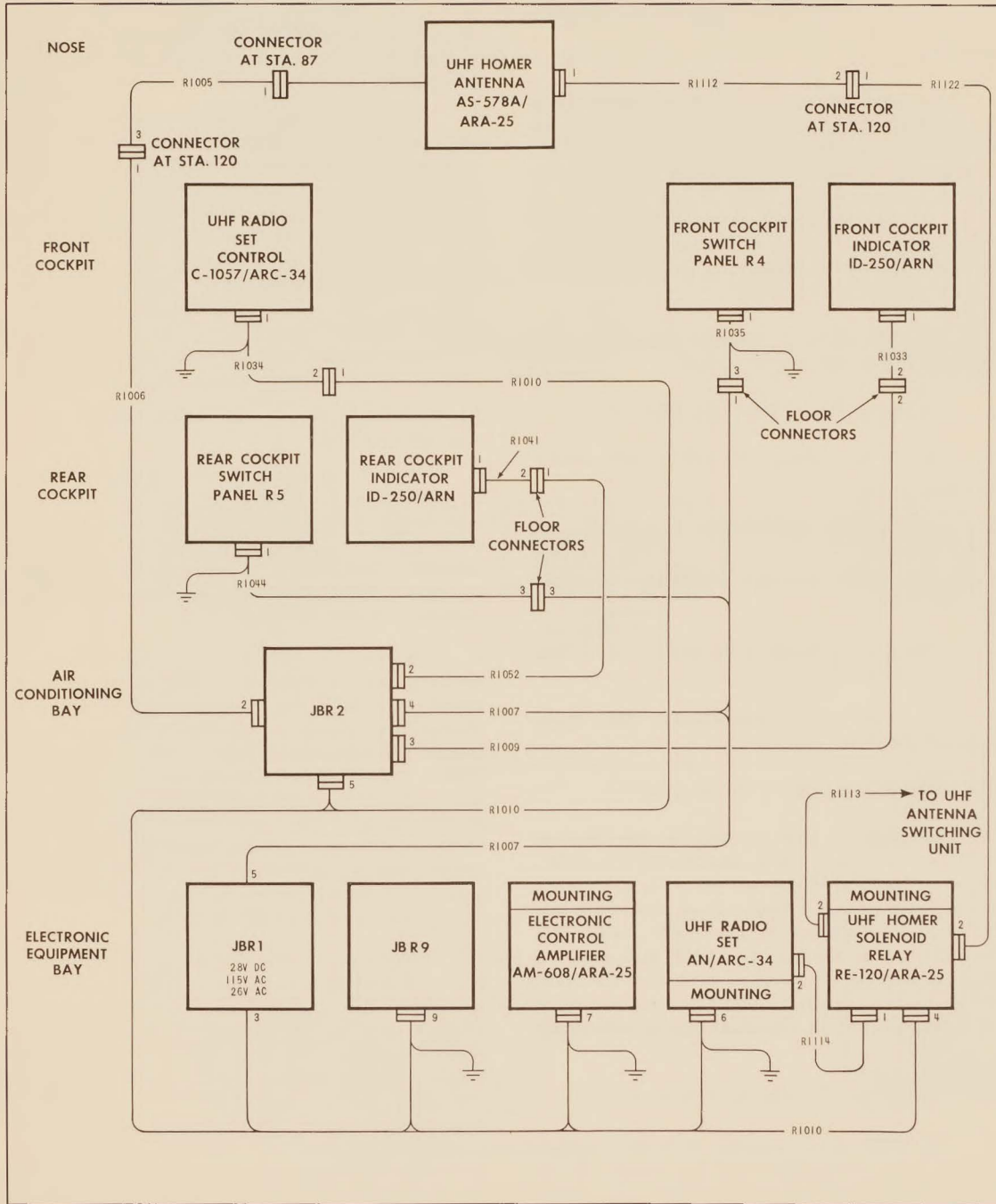

TWJ-7015-4

FIG. 1 UHF HOMER ADAPTOR AN/ARA-25 - GENERAL ARRANGEMENT

ARROW 1 SERVICE DATA

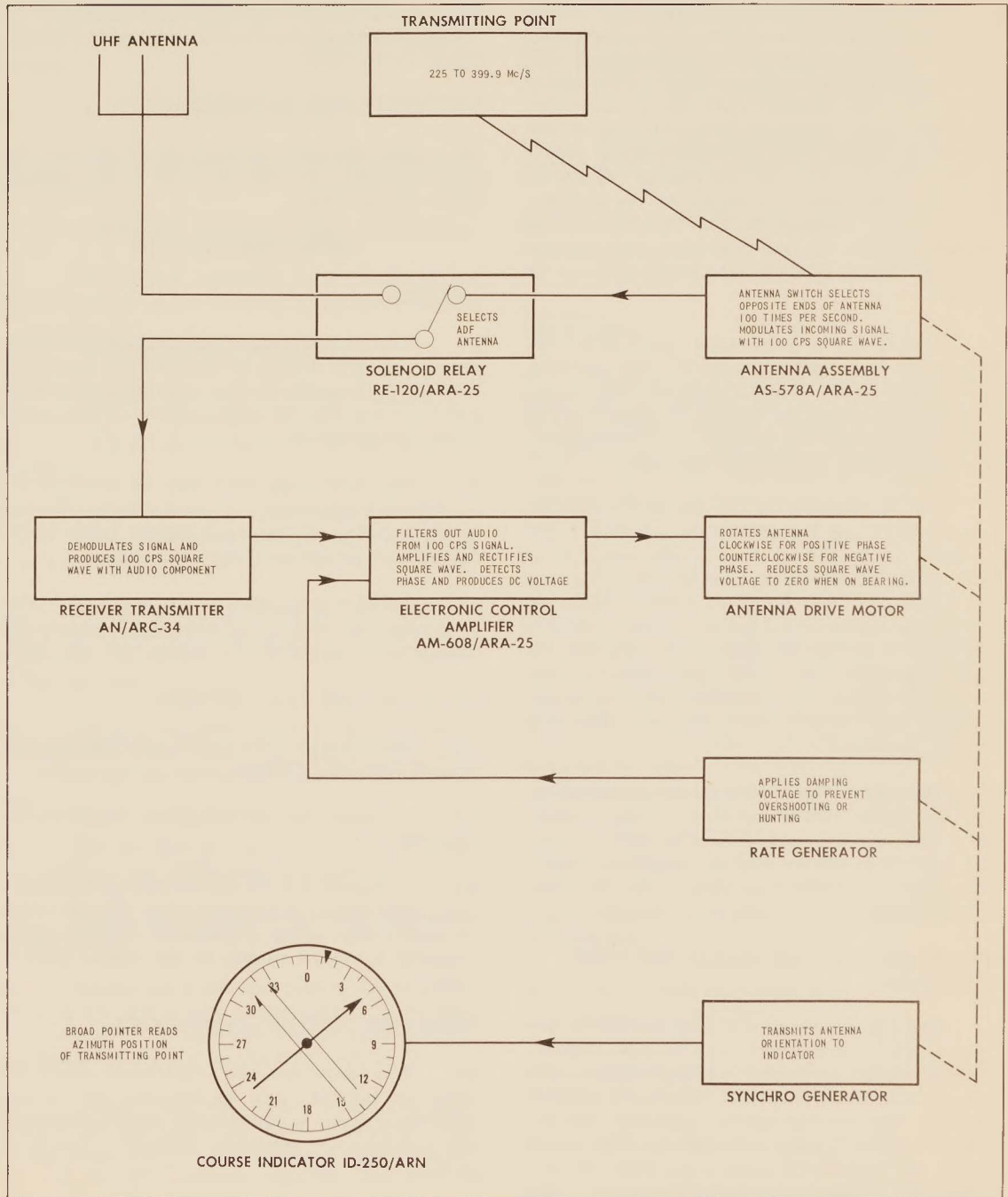

7MI-7035-1

FIG. 2 UHF HOMER ADAPTOR AN/ARA-25 - FUNCTIONAL BLOCK DIAGRAM

## UNCLASSIFIED ARROW 1 SERVICE DATA

10 A positively phased voltage will cause the antenna motor to rotate in a clockwise direction, and a negatively phased voltage will cause counter-clockwise rotation. The motor will rotate the antenna until the cross-over point of the two cardioid field patterns of the antenna is in line with the transmitting point. In this position, the level of signal voltage at each end of the antenna is equal and the square-wave control voltage in the system will be reduced to zero. In this condition, the antenna is on bearing and the drive motor ceases to rotate.

11 The synchro generator, geared to the antenna drive motor, transmits the antenna orientation to the radio magnetic indicators. The rate generator provides damping for the system to prevent the antenna overshooting or fluctuating about the bearing position.

12 Two screwdriver adjustment controls, marked GAIN and DAMPING respectively, are provided on the front face of the amplifier. Both controls are preset and locked during bench testing. The GAIN control is adjusted so that the speed of response of the indicator needle to direction change is not less than 30 degrees per second. The DAMPING control is adjusted so that the indicator needle does not fluctuate (hunt) more than 3 degrees about the bearing position.

13 Mounted in the front face of the amplifier are two fuses, F101 current rating 1 amp, and F102 current rating 1/16 (0.0625) amp. Fuse F101 is in series with the amplifier heater circuit and fuse F102 is in series with the plate supply circuit.

COURSE INDICATORS (DUAL) RM1 TYPE  
ID-250/ARN

14 Homing bearings are registered by two radio magnetic indicators, one in each cockpit. The indicators are dual reading instruments with two indicating needles, one broad and one narrow. The narrow needle operates with the Radio Compass System AN/ARN-6. The broad needle operates with either the UHF Homer System or, if fitted, the TACAN system. RMI Needle Selector switches, located one on the front cockpit switch panel R4 and one on the

rear cockpit switch panel R5, are provided to select the broad needle for operation with the system required.

## SYSTEM POWER REQUIREMENTS

15 The system operates on 27.5 volts DC with an input current of 2.85 amps, and 26 volts AC at 6VA.

## FUNCTION TESTING

## GENERAL

16 Function testing of the AN/ARA-25 UHF Homer system should be carried out periodically as laid down in the servicing schedule, and after overhaul or replacement of associated items of equipment.

17 The following test can be carried out quickly in the hangar. The screening afforded by the building will prevent signals from interfering with communication channels.

18 A UHF signal generator type TS-497/URR or equivalent and a portable 0.25 metre rod antenna are required to carry out the test.

## PREPARATION FOR TESTING

19 Prepare to carry out function testing proceeding as follows:

(a) Connect an external power supply to the aircraft.

(b) Connect a 0.25 metre portable antenna to a UHF signal generator type TS-497/URR or equivalent, using a length of coaxial cable. Connect a power supply to the signal generator.

## FUNCTION TESTING PROCEDURE

20 Two operators are required to carry out function testing, one to operate the cockpit controls and one to operate the signal generator and position the portable antenna. The procedure is as follows:

(a) Select to ON the master electrical switch in the front cockpit.



## ARROW 1 SERVICE DATA

(b) Select the controls on the radio set control C1057/ARC-34 in the front cockpit as follows:

- (1) Function selector switch to ADF.
- (2) Operational mode selector switch to MANUAL.
- (3) VOLUME control fully clockwise.

(c) Select the controls on the interphone control panel in the front cockpit as follows:

- (1) COMM mixing switch on.
- (2) Rotary selector switch to COMM.
- (3) VOL control to the 12 o'clock position.

(d) Select the RMI needle selector switches on the front cockpit switch panel R4 and the rear cockpit switch panel R5 to UHF HOMER.

(e) Set the UHF signal generator to 226.8 Mc/s unmodulated and position the portable antenna at a distance of 10 to 20 feet dead ahead of the aircraft.

(f) Plug a headset type H-70/AIC and a microphone M33/AIC-10 or equivalents into the quick-release connector on the front cockpit seat.

(g) Set up the frequency 226.8 Mc/s manually on the UHF radio set control.

(h) Allow five minutes for the equipment to warm up.

(j) Listen for a 100 cps tone in the headset, varying the frequency of the signal generator, if necessary, to tune the signal generator to the same frequency as the UHF receiver.

(k) Check that the radio magnetic indicators ID-250/ARN in the front cockpit and in the rear cockpit indicate the approximate bearing of the portable antenna relative to the aircraft. Bearing accuracy of better than 15 degrees cannot be expected on ground checks.

(m) Move the portable antenna to several positions around the aircraft and check that the radio magnetic indicators respond to the direction changes rapidly and definitely.

(n) Repeat operations (e) through (m) using frequencies 324.3 Mc/s and 384.5 Mc/s.

(p) Switch off the equipment.

## REMOVAL AND INSTALLATION

## GENERAL

21 The majority of the units comprising the UHF Homer Adaptor System AN/ARA-25 are removed by disconnecting cables and unscrewing mounting or securing bolts. Where it is considered necessary, the procedure for removal and installation of various units is described in more detail.

22 The electronic control amplifier and solenoid relay are mounted in the electronic equipment bay. Access is gained by lowering the electronic equipment bay centre access door which is hinged at the aft end to open outwards and is secured by 33 camloc fasteners. One fastener, clearly marked, must be released last and secured first. The door is raised and lowered by means of an electric motor actuator controlled by a switch located adjacent to the door. Access to the switch is gained by releasing two camlocs securing an access flap.

ELECTRONIC CONTROL AMPLIFIER -  
REMOVAL

23 To remove the electronic control amplifier proceed as follows:

- (a) Release the two quick-release fasteners holding the unit to its mounting.
- (b) Disconnect the ground wire.
- (c) Disconnect cable assembly R1010-7.
- (d) Lift the unit out of the mounting.

UNCLASSIFIED

CONFIDENTIAL

## ARROW 1 SERVICE DATA

### ELECTRONIC CONTROL AMPLIFIER - INSTALLATION

24 The procedure for installing the electronic control amplifier is the reverse of that given for removal.

### SOLENOID RELAY - REMOVAL

25 To remove the solenoid relay proceed as follows:

- (a) Release the two quick-release fasteners holding the unit to its mounting.
- (b) Disconnect cable assemblies, R1113-2, R1114-1, R1010-4 and R1122-2.
- (c) Lift the unit from its mounting.

### SOLENOID RELAY - INSTALLATION

26 The procedure for installing the solenoid relay is the reverse of that given for removal.

### UHF HOMER ANTENNA - REMOVAL

27 Access to the UHF Homer Antenna is gained by removing the access panel from the underside of the nose section of the aircraft at station 100.

28 To remove the UHF homer antenna proceed as follows:

- (a) Remove two clamps holding the antenna power cable assembly to the aircraft structure.
- (b) Disconnect the antenna power cable from the connector at station 87.

(c) Disconnect cable assembly R1112-1 from the antenna.

(d) Remove six screws holding the antenna to the aircraft structure.

(e) Carefully detach the antenna from the aircraft structure to avoid damage to the receptacle protruding from the antenna.

### UHF HOMER ANTENNA - INSTALLATION

29 The procedure for installing the UHF homer antenna is the reverse of that given for removal.

### COURSE INDICATOR (FRONT COCKPIT AND REAR COCKPIT) - REMOVAL

30 To remove the course indicator from the main instrument panel in the front cockpit or the main instrument panel in the rear cockpit proceed as follows:

- (a) Remove four mounting screws and withdraw the indicator from the panel.
- (b) Disconnect cable assembly R1033-1 in the front cockpit or R1041-1 in the rear cockpit, from the receptacle on the rear of the instrument.

### COURSE INDICATOR (FRONT COCKPIT AND REAR COCKPIT) - INSTALLATION

31 The procedure for installing the course indicators is the reverse of that given for removal.



ARROW 1 SERVICE DATA

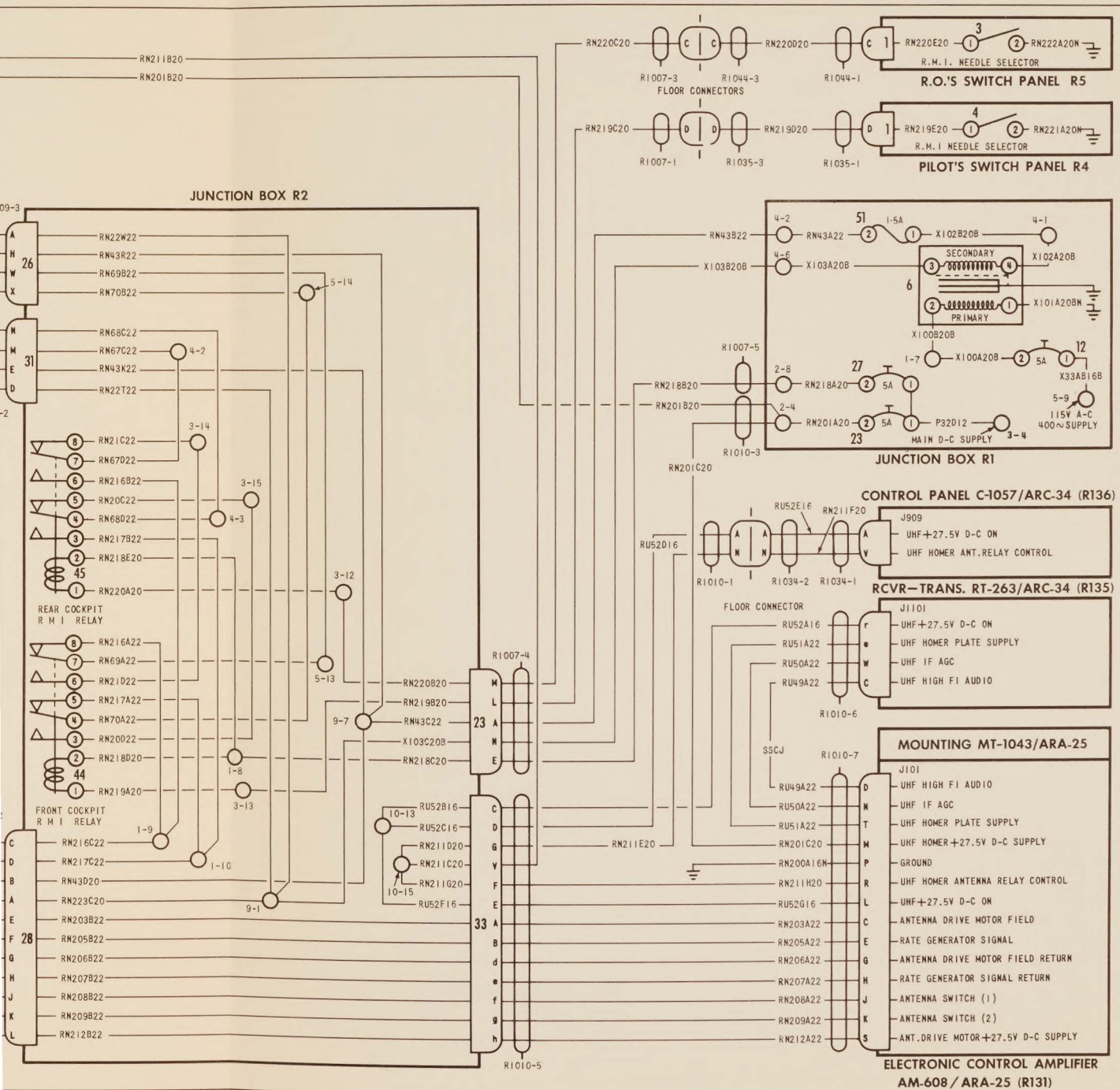

FIG. 3 UHF HOMER ADAPTOR AN/ARA-25



## ARROW 1 SERVICE DATA

UNCLASSIFIED

## EQUIPMENT LIST

PART NO.	MANUFACTURER	NOMENCLATURE	UNITS PER ASSEMBLY
AM-608/ARA-25	GFE	Electronic Control Amplifier	1
RE-120/ARA-25	GFE	Solenoid Relay	1
AS-578A/ARA-25	GFE	Antenna	1
MT-1042/ARA-25	GFE	Mounting, Solenoid Relay	1
MT-1043/ARA-25	GFE	Mounting, Electronic Control Amplifier	1
ID-250/ARN	GFE	Course Indicator - (See also Section 41)	2

