

G. T. WOODS.  
AUTOMATIC AIR BRAKE.

(Application filed Feb. 5, 1901.)

(No Model.)

3 Sheets—Sheet 1.

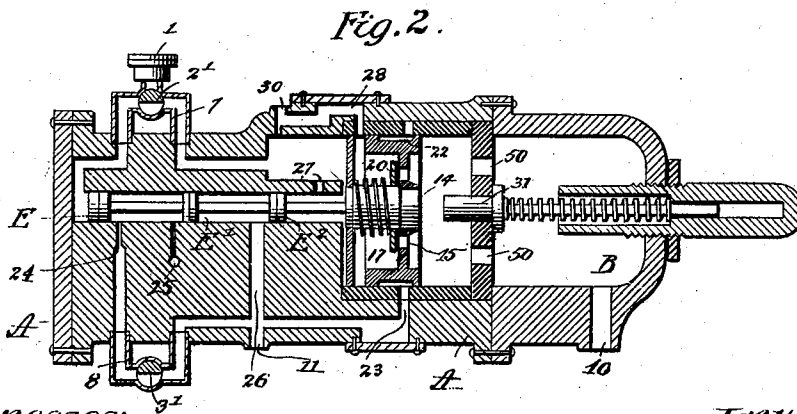
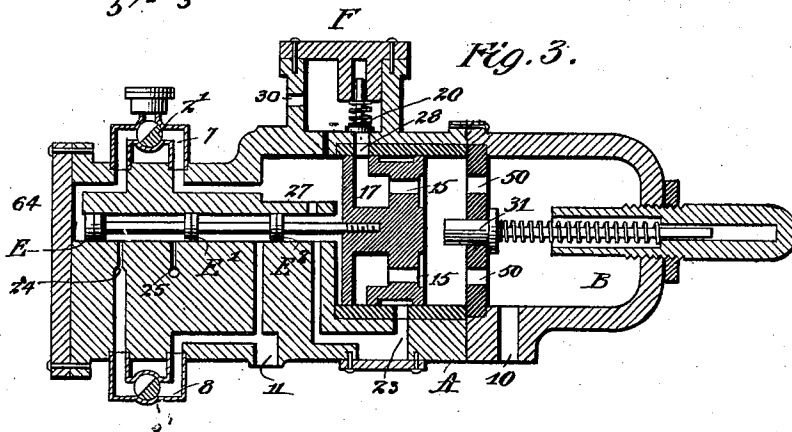
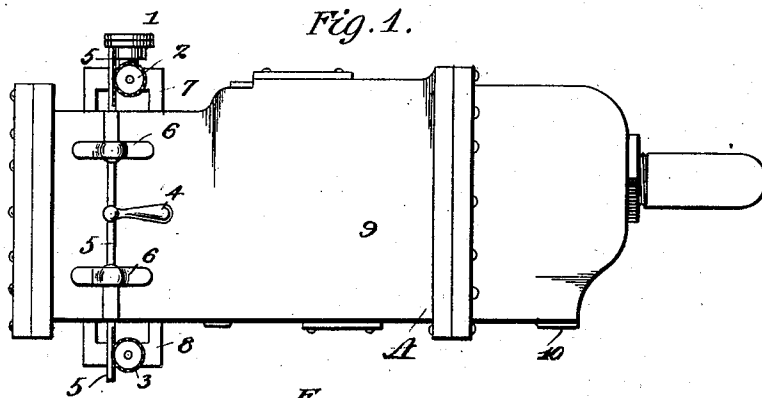

Witnesses:

C. L. Belcher.  
G. T. Woods.

Inventor  
G. T. Woods.

G. T. WOODS.  
AUTOMATIC AIR BRAKE.

(Application filed Feb. 5, 1901.)

(No Model.)

3 Sheets—Sheet 2.

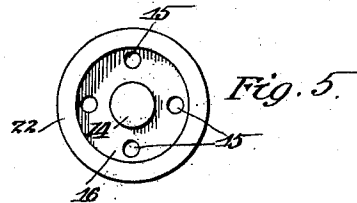
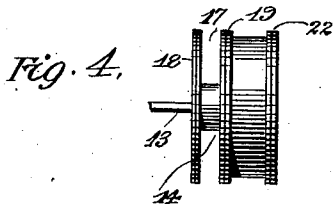
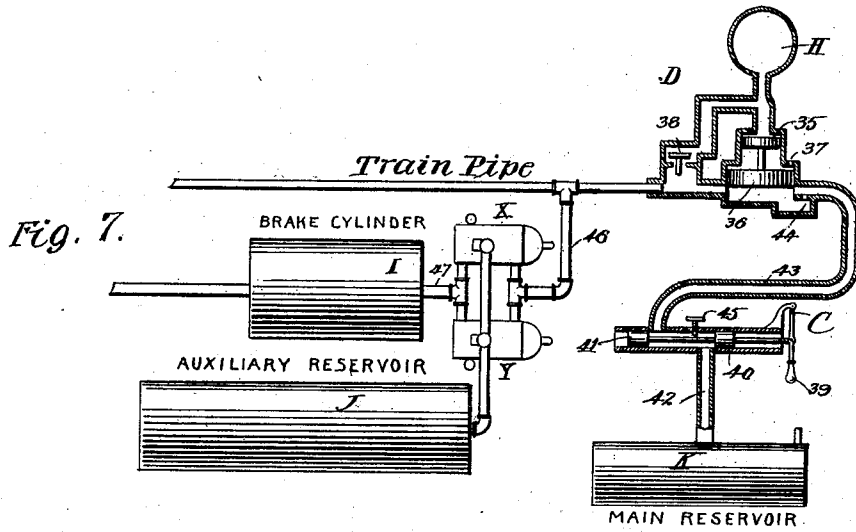
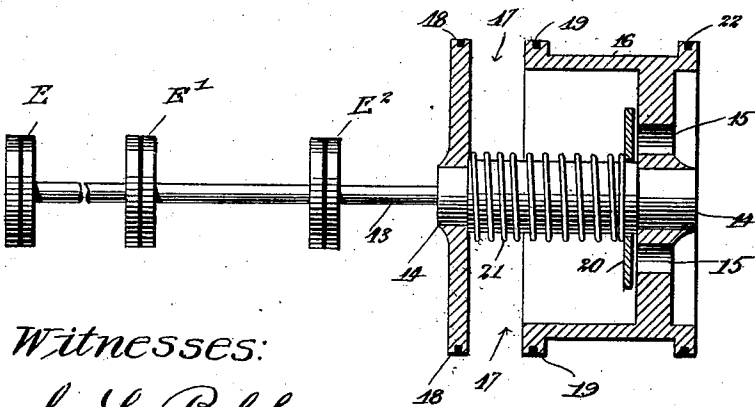

Fig. 6.



Witnesses:

C. L. Belcher  
Lydia Woods,

Inventor  
G. T. Woods.

No. 701,981.

Patented June 10, 1902.

G. T. WOODS.  
AUTOMATIC AIR BRAKE.

(Application filed Feb. 5, 1901.)

(No Model.)

3 Sheets—Sheet 3.

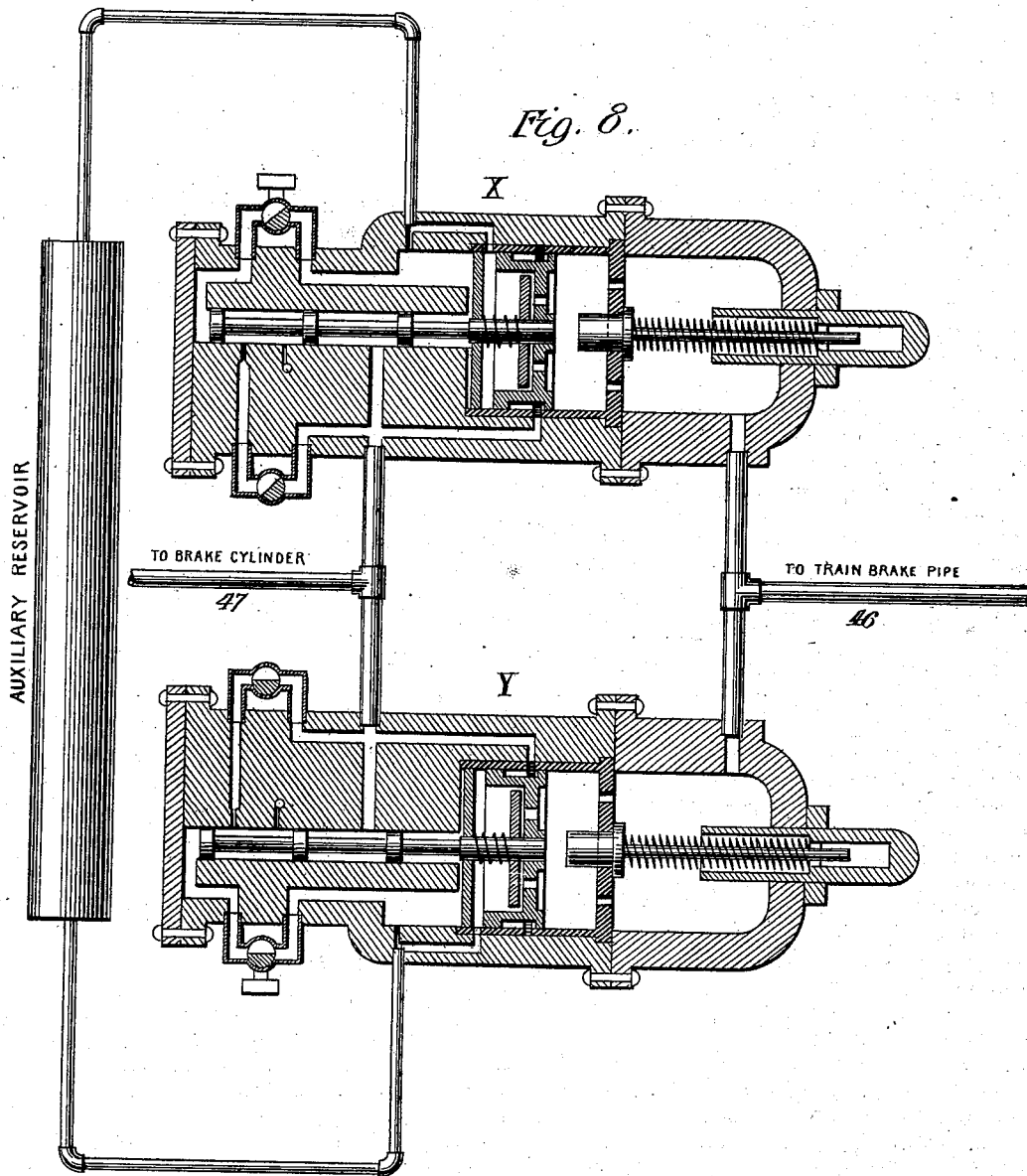

WITNESSES:

*Lyatis Woods.*  
*S. G. Woods.*

INVENTOR

*G. T. Woods.*

# UNITED STATES PATENT OFFICE.

GRANVILLE T. WOODS, OF NEW YORK, N. Y., ASSIGNOR, BY MESNE ASSIGNMENTS, TO THE WESTINGHOUSE AIR BRAKE COMPANY, OF PITTSBURG, PENNSYLVANIA, A CORPORATION OF PENNSYLVANIA.

## AUTOMATIC AIR-BRAKE.

SPECIFICATION forming part of Letters Patent No. 701,981, dated June 10, 1902.

Application filed February 5, 1901. Serial No. 46,080. (No model.)

*To all whom it may concern:*

Be it known that I, GRANVILLE T. WOODS, a citizen of the United States, and a resident of New York, in the county of New York and State of New York, have invented certain new and useful Improvements in Automatic Air-Brakes, of which the following is a specification.

My present invention relates to the peculiar construction and arrangement of the valves and other parts of an automatic brake mechanism which is preferably operated by compressed air.

My invention has for one of its objects to compel a positive action of each brake when the same is expected to "go on," to stop the car, or to "come off," and thereby release the car.

Railway accidents are reported frequently as being due to the failure of the air-brake systems; and it is one of the objects of my present invention to avoid some of the weak points of the familiar systems in daily use.

The brake system in general to which my present improvements are shown applied is that in common use and includes, in addition to the brake-cylinder, auxiliary reservoir, and train-pipe, the usual equipment on the locomotive—such as an air pump or compressor, a storage-tank, and an engineer's valve—all of which parts are familiar to persons skilled in the construction and operation of brake mechanisms. In addition to the parts named a complete automatic air-brake system includes as one of its essential elements a valve mechanism located on each car and serving to control the admission and escape of air in the brake-cylinder for effecting the application and release of the brakes. Such valve mechanism is popularly known as "triple-valve" mechanism, and the present improvements relate more particularly to the valve element or part of the brake system and introduces a peculiar mode of operation, notwithstanding the fact that I employ the usual pressure of air when causing a gradual application of the brakes and also when a "quick-action" or emergency stop is being made, the gradual application being produced by energy from the auxiliary reservoir; but the quick

action is caused by an initial air-supply from the train-pipe to the brake-cylinder and a final air-supply from said auxiliary reservoir to the said brake-cylinder.

It is well known to those skilled in the profession of locomotive-running that if an air-brake on one car fails to go on it not only causes the loss of the braking effect of that particular car-brake, but it also causes the other brakes of the train to lag or go on slowly, because the air-pressure in the train-pipe in such cases is not reduced quickly, there being one less brake-cylinder to take a portion of said air from said train-pipe, and thereby accelerate the remaining valve apparatus. It is also well known that if an emergency stop is made at a time when the brake system is normal the time and distance required in which to make the stop is short, while the same train will require a longer time and distance in which to cease its motion when the brake system is slightly abnormal. The difference between the short time and distance demanded in the one case and the longer time and distance required in the other case is often the span between life and death. To insure a far more positive, powerful, and a much quicker action than is possible to be obtained by the use of the familiar systems aforesaid, I have provided a novel construction and arrangement of the main or double-acting-valve part, the valve of which may be of any suitable kind and combined with the valve-piston part (I term the combination a "valve device") and the various ports, so that not only will the valves and other parts cooperate, but they may be incorporated with the valve mechanism of the well-known Westinghouse air-brake system or any form of air-brake which will operate interchangeably with said Westinghouse system. Furthermore, by the addition of one of my valve devices to each car which is at present supplied with the said Westinghouse system or the New York air-brake apparatus or some similar equipment a system will thereby be produced which will embody the majority of the most valuable features of my present invention, and thus add greatly to the reliability of the common air-brake equipment.

To more fully understand my invention, reference is made to the accompanying drawings, in which—

Figure 1 is a side view of the outside case of my invention. Fig. 2 illustrates a sectional view of the casing and some of the parts of Fig. 1. In Fig. 3 is shown a sectional view of some of the parts and a full side view of other parts of a modification of my invention. Fig. 4 is a side view of the valve-piston part. Fig. 5 is a face view looking from right to left of said valve-piston part. Fig. 6 is an enlarged sectional view of the valve device illustrated in Figs. 2 and 8. Fig. 7 illustrates one way of connecting up the brake-system, so that if one of the valve devices or a valve should fail to operate the other valve device will operate, so that the brake-cylinder will be certain to receive the air-pressure required for its operation. Fig. 8 is a sectional view of the valve devices and their casings when such are arranged as shown in Fig. 7.

In Fig. 1 the part indicated by numeral 1 is an air vent or box which is filled with cotton or some other suitable porous material, so that when the air is drawn through the same from the outside atmosphere, as hereinafter set forth, the porous material then acts as a filter, serving to prevent grit or dirt from entering the valve-chamber or valve-space which is within the valve-case. Valves 2 and 3 are controlled by moving handle 4 upward or downward. The direction in which said handle is moved will of course depend upon which of the air-passages are to be opened and which are to be closed. Said handle connects with valves 2 and 3 through rod or bar 5, as shown in the drawings. 6 6 are guides for bar 5. The ends of said bar and the outer ends of said valves are provided with teeth, so as to produce what is termed a "rack-and-pinion" movement. 7 and 8 are the passage-ways or air-pipes controlled by valves 2 and 3.

In Figs. 2, 4, 5, 6, and 8 I have shown the valve device which controls the various ports. When I use the words "valve device" I mean the valve-piston and the main valve acting as different parts of one device, one of said parts controlling the admission of air from the auxiliary reservoir to the brake-cylinder, while the other part governs the air-admission from the train-pipe to the brake-cylinder. The valve device or, in other words, the valve-like device and the parts connected thereto are more clearly illustrated in Fig. 6, which is the preferred form, enlarged so that the parts may be more readily indicated and understood, and the same may be used as a reference to assist in the explanation of Fig. 2, &c. The preferred construction of said apparatus is as follows: The main-valve part, as shown in this case, is what is technically termed a "piston-valve" and the piston part to which said valve is connected and by which it is moved is (in the present art)

technically termed a "valve-piston," each part being so named because of its peculiar construction, movements, and the work it performs. The main-valve part herein shown has three partitions E E' E<sup>2</sup>. These are fixed upon stem 13, which in turn is firmly attached to the hub 14 of the valve-piston part. The valve-piston part of the valve device may be made in one piece, as shown in Fig. 3, or it may be composed of several parts, as shown in Fig. 2. The valve-piston part has one or more ports or passages 15, leading through the web or wall 16 into piston-port 17 in the body of the said piston, thence out at the port-opening between the wall 18 and flange 19. In Figs. 2, 6, and 8 the said ports 15 are closed one way by check-valve 20, which is held to its seat by spring 21. In practice the space between flanges 19 and 22 is sufficiently great to normally cover port 23, which (when open or uncovered by the valve-piston part) leads from the train brake-pipe through passage 11 to the brake-cylinder. The three partitions E E' E<sup>2</sup> of the main-valve part are arranged in the following manner: Partitions E and E' are so arranged that the restricted port 24 is normally between them, while the restricted exhaust-port 25 is always between them. Port 26 is always between partitions E' and E<sup>2</sup>, while port 27 is normally between partition E<sup>2</sup> and wall 18. Now as the valve device moves from the extreme end of its path at the left to the other extreme end of its path to the right (as in emergency stops) then partition E moves to another position between ports 24 and 25. Partition E' remains in its normal pathway between ports 25 and 26, while partition E<sup>2</sup> takes up a new position between port 27 and wall 18, at which time the brakes will go on. When the engineer causes the valve device to move to "take off" the brakes, said partitions take up their normal positions to the left. In Fig. 3 the check-valve 20 is arranged in a valve-box outside of the case A. In this arrangement valve 20 normally covers port 28. When valves 2' and 3' are open, as in Fig. 2, then passage 7 leads from the auxiliary-reservoir opening 30, around through valve 2' to opening 11, thence to the brake-cylinder.

In some brake systems the auxiliary reservoir is charged to the same restricted port or passage which communicates between the auxiliary reservoir J and the brake-cylinder I. In my apparatus as illustrated in Figs. 2, 3, &c., the passage 28 is for charging the auxiliary reservoir J, and said passage is arranged as a "by-pass"—that is, it provides a large direct passage around the restricted port (through which air is supplied from the auxiliary reservoir to the brake-cylinder) directly to the opening 30, leading to the auxiliary reservoir, thus avoiding the slow reservoir-recharging process used in said familiar systems. By the arrangement herein set forth the engineer is permitted to recharge

the auxiliary reservoir while the brakes are on or applied. This new and valuable feature is the result of the peculiar arrangement of the ports and valves, and its value is great when a long heavy train is running down-grade and the engineer desires to keep the train under control. It is well known that when the brakes are "on" the air constantly leaks from the brake-cylinder. Hence the necessity of recharging the auxiliary reservoir while the brakes are on.

It will be observed that valves 2' and 3' (shown in Fig. 3 and also in the upper portion X of Fig. 8) are set to obstruct the passages 7 and 8, which said valves control, while in Fig. 2 and also the lower part Y of Fig. 8 valves 2' and 3' are set to permit an open way through said passages. These valves are never set to obstruct the air-passages except when two valve devices and their inclosing cases communicate with one brake-cylinder, as shown in Figs. 7 and 8, one of said valve devices acting as a graduating main valve, while the other valve device acts as an emergency-valve only, operating only when emergency stops are being made. Whenever two valve devices are coupled up, as shown in Figs. 7 and 8, one of the said devices is converted into a differential piston—that is to say, the valves 2' and 3', while being turned, as shown in said figures, so as to obstruct the passages 7 and 8, leading to or from the valve-piston part, will simultaneously open a passage leading from the outer end E of the main-valve part, through box or vent 1, to the outer atmosphere. Now if air under pressure is admitted to both sides of the valve-piston part the total number of pounds useful pressure upon the said piston-surface next to partition E<sup>2</sup> will be less than the total number of pounds useful pressure on the piston-surface next to the adjusting-stem 31, this difference in the useful pressures being due to the counteracting influence of the surface of partition E<sup>2</sup>, which is so exposed as to oppose the pressure against the piston-surface next thereto. It will be noted that as partition E is not exposed to the air-pressure when said air-passages are obstructed the end surface thereof cannot be taken into the calculation. The surfaces of partition E<sup>2</sup> and piston-wall 18 should be so proportioned that the arrangement as a differential piston will remain quiescent unless required to act when making an emergency stop, at which time about twenty pounds reduction is made in the train-pipe air-pressure, so that the preponderance of pressure will be on the auxiliary-reservoir side of said piston part. Then the auxiliary-reservoir air-pressure will move the said differential piston back toward the right until it reaches the extreme limit of its path, as hereinafter explained, thus acting absolutely independent of any motion (or the effect of any motion) which the associate graduating main-valve device may make.

In Fig. 7 I have shown a main air-pressure reservoir, an auxiliary reservoir, a brake-cylinder, two valve devices X and Y, an engineer's valve C, and an automatic discharge-limit valve, which is connected in the train-pipe at point D between the engineer's valve and the brake apparatus. The object of said discharge-limit valve is to prevent the escape of more than a predetermined amount of air through the action of the engineer's valve when an emergency stop is to be made. It is well understood that when an emergency stop is to be made the engineer suddenly discharges twenty pounds (more or less) from the train-pipe. When said reduction of train-pipe pressure takes place, the valve mechanism should act promptly to admit air from the train-pipe and also from the auxiliary reservoir to the brake-cylinder. Now when an emergency stop is required the engineer has no time to gage the escaping air. Therefore a much greater reduction of the air-pressure takes place than such cases demand, thus reducing the amount of compressed air which should have passed from the train-pipe into the brake-cylinder instead of being discharged into the atmosphere, and thereby reducing the efficiency of the brake system and adding to the time required to effect a stop. The arrangement of the discharge-limit valve is as follows: Parts 35 and 36 form the two heads of a differential piston, said heads being connected by a stem, as shown, or head 35 may be made in the form of a plunger, if so desired. This said piston moves within a case or cylinder in the usual way, as shown. The usual vent is indicated at 37. An air-reservoir is shown at H and a check-valve at 38. The operation is as follows: The lever 39 of the engineer's valve is shown in position to admit air under pressure from reservoir K through pipe 42 into the space between the valve-heads 40 and 41, thence through pipe 43, under piston-head 36, then to the train-pipe. Meanwhile some of the air forces its way past check-valve 38 and accumulates in reservoir H and the tubular communications immediately connected therewith. Thus there will be a pressure against both ends or heads of said differential piston, and when the pressure in said reservoir H is equal to that in the train-pipe the check-valve 38 will be seated and the air in reservoir H will be "entrapped" or confined. The under surface of head 36 being greater in square inches than the upper surface of head 35 permits the preponderance of pressure to move the piston upward to the position shown in the drawings. Now if the engineer pulls lever 39 to the right until it reaches the limit of its travel by being brought up against screw 45 then air will rush out from the train-pipe and past the outer end of head 41. As soon as the pressure in the train-pipe has been reduced to the predetermined limit the preponderance of pressure will then be against the small head 35 of said differential piston, and therefore said piston will be

forced down to its seat. In other words, the pressure of the said entrapped air is not reduced by the reduction of the train-pipe pressure. Therefore when the train-pipe pressure is reduced to a point where its total number of pounds pressure against head 36 is below the total number of pounds pressure exerted against head 35 by the entrapped air then the said piston will be forced down to its seat, and thereby limiting the reduction of the train-pipe pressure by closing or obstructing the train-pipe at the appropriate moment, thus permitting the air to be transferred while at its highest permissible pressure from the train-pipe to the brake-cylinder. When the train-pipe is to be recharged, lever 39 is moved to the position shown in the drawings. Then air will pass from the reservoir K, as hereinbefore set forth, until it reaches passage 44, through which the air has access to the under side of piston-head 36, which will then be forced upward until it reaches the position shown in the drawings. Air will in the meantime recharge the train-pipe and the auxiliary reservoirs. It will be noted that the discharge of air is automatically limited or stopped independently of the engineer's valve. When connecting up a single valve device to a car, connections are made between the train-pipe and valve-case A, as follows: A branch pipe leads from said train-pipe and connects with said case at point 10. Another connecting-pipe is placed between the brake-cylinder and said case at point 11, while a third pipe connection is supplied between the auxiliary reservoir and said case at point 30. The train-pipe has the usual connections from car to car, &c. When a single valve device is used, the operation is as follows: To charge the auxiliary reservoir and prepare the brakes for action, air at about seventy pounds pressure is permitted to flow from the main reservoir K through the train-pipe and its connections into opening 10, (of valve-case A,) thence through chamber B, passages 50, ports 15, around check-valve 20, through piston-port 17, port 28, passage 30, to the auxiliary reservoir. A portion of the air passes along through passage 7, valve 2, to the outer side of partition E. In the meantime the valve device has been forced to the extreme left of case A. Thus the brake-cylinder is cut off from the train-pipe and the auxiliary reservoir, and the exhaust-passage is open between the brake-cylinder and the atmosphere. When it is desired to apply the brake gradually, the handle 39 of the engineer's valve will be moved for a moment to such a position that communication between the main reservoir K on the engine and the train-pipe will be closed and an escape-passage is open between the train-pipe and the atmosphere. Thereby the air-pressure in the train-pipe will be reduced about five pounds. This reduction of pressure on the train-pipe side of the valve-piston part disturbs the balance previously existing on the opposite sides there-

of, resulting in establishing a preponderance of air-pressure on the auxiliary-reservoir side, and the air delivered from the auxiliary reservoir through passage 30 and acting upon the valve-piston part causes the valve device to move toward the right. This movement will continue until partition E has passed to the right of port 24, thus allowing auxiliary-reservoir air to flow through passages 30 and 7, valve 2', to port 24, thence through passage 8 and valve 3', passage 11, to brake-cylinder, where it acts upon the piston thereof to cause the brakes to go on. When by reason of the flow of air into the brake-cylinder the pressure in the valve-chamber and auxiliary reservoir has been reduced to or below that of the train-pipe, a slight return or leftward movement of the valve device will be produced, (by the combined action of the train-pipe pressure and the adjusting-stem 31), sufficient to cause the partition E to rest upon and close port 24, and thus close communication between the valve-chamber and the brake-cylinder and confine the air admitted within the latter. In case it is desired to gradually increase the air-pressure in the brake-cylinder the above operation is repeated. To permit the air in the brake-cylinder to escape and "let off" or release the brakes, the air-pressure in the train-pipe is restored or increased by a proper and well-known movement of the engineer's valve. The increase of pressure in the train-pipe causes the valve device to move leftward to the limit of its path, when it will occupy the position shown in Fig. 2, &c., thereby placing restricted port 24 in communication with exhaust-port 25 and allowing the brake-cylinder air to escape. It should be understood that in practice I cause the passage which directly connects with exhaust-port 25 to be much more restricted than any of the other said passages, thereby causing the exhaust from the brake-cylinder to be very gradual. At the same time the restoration of the pressure in the train-pipe will unseat check-valve 20, (after the piston-port 17 registers with port 28,) and air from the train-pipe will flow into the auxiliary reservoir, recharging it for future use. The pressure in the auxiliary reservoir will then equal that in the train-pipe, when the check-valve 20 will be seated by its spring 21. When it becomes necessary to recharge the auxiliary reservoir while the brakes are on, the engineer moves his valve suddenly and connects the main reservoir K to the train-pipe. This causes the valve devices to move quickly to the full limit of their paths toward the left, thus placing the auxiliary reservoir in communication (through large passages) with the fully-charged train-pipe, thus causing the auxiliary reservoir to be charged in an instant. The passage from the brake-cylinder through the exhaust (said passage being open while said recharging was being accomplished) is quite small or restricted at the ports. Therefore the air which

is confined in said brake-cylinder will have escaped but slightly before said auxiliary reservoir was fully charged and the engineer discharged some air from the train-pipe as when first applying the brakes. Thus it will be noted that the brake-cylinder was permitted to receive a second supply of air-pressure before the first supply was exhausted. When it becomes necessary or desirable to apply the brakes quickly and with full power for an emergency stop, the engineer's valve will be moved to close the communication between the main reservoir K and the train-pipe and open the latter to the atmosphere and produce a sudden reduction of pressure of about twenty pounds in the train-pipe. The effect of this sudden diminution of pressure in the train-pipe is immediately manifest at the discharge-limit valve (which acts instantly) and the nearest valve device or that on the first car, causing the valve device to be moved by the higher pressure of auxiliary-reservoir air quickly toward the right to the end of its path. Then port 23 registers with the piston-port 17 of the valve-piston part, and thereby placing the auxiliary reservoir and the train-pipe in communication with the brake-cylinder and closing the exhaust-port. The following passages are now open: A pathway leads from opening 30 through passage 7, valve 2', port 24, passage 8, valve 3' to opening 11, thence to the brake-cylinder. Another communication is from opening 30 through ports 27 and 26 to opening 11, thence to the brake-cylinder. Yet another air-pathway is from opening 10 through chamber B, opening 50, ports 15, piston-port 17, and port 23 to opening 11, thence to the brake-cylinder. The auxiliary reservoir and the train-pipe being thus brought suddenly into communication with the brake-cylinder passages will cause check-valve 20 to be immediately unseated and train-pipe air will pass along said path between opening 10 and opening 11, thence directly into the brake-cylinder, thus effecting the quick initial application of the brakes and also a further reduction of pressure in the train-pipe that will be sufficient to accelerate the action of the valve mechanisms on the cars following. The valve-piston part will in the meantime be held to its outward position (toward the right) by the relatively higher air-pressure from the auxiliary reservoir, which is delivered through large passage 30, while the transmission of the auxiliary-reservoir air from passage 30 to the brake-cylinder is retarded by having to pass through the restricted port 24. After the air-pressures in the train-pipe and the brake-cylinder have equalized auxiliary-reservoir air will continue to flow from the auxiliary reservoir into the brake-cylinder until there is an equalization of air-pressure in both said auxiliary reservoir and brake-cylinder. Then adjusting-stem 31, together with the train-pipe pressure, will move the valve device toward the left until

partition E covers port 24. It will be seen that the valve-piston part is moved in one direction by the auxiliary-reservoir pressure, the return movement being produced by the train-pipe pressure or adjusting stem 31, or both combined, as hereinbefore set forth. It will be noted that by restricting the flow of auxiliary-reservoir air a considerable volume of train-pipe air is allowed to flow freely into the brake-cylinder, notwithstanding the admission to the brake-cylinder at the same time of a small volume of the auxiliary-reservoir air under a higher pressure. An appreciable period of time is required to raise the pressure in the brake-cylinder to that in the auxiliary reservoir, and it is during this interval and before the pressure in the brake-cylinder is raised to that in the train-pipe the air in the latter is free to enter the brake-cylinder. To release the brakes, a sufficient amount of air is admitted from the train-reservoir K to the train-pipe to overcome the resistance of the auxiliary-reservoir pressure and friction of the valve mechanism and move the valve device to the end of its stroke, (toward the left, as shown in Fig. 2, &c.) and thereby establish a communication between the brake-cylinder and the atmosphere by way of the exhaust-passage 25. It will be noted that ports 26 and 27 are brought into use only when an emergency action of the valve device takes place. In making a gradual stop the valve device is not moved far enough to the right to allow ports 26 and 27 to communicate with each other.

In Fig. 8 I have illustrated an arrangement in which two valve devices (such as shown in Fig. 2) are so coupled up that both parts X and Y are permanently and independently connected to the train-pipe, the brake-cylinder, and the auxiliary reservoir; but the valve devices of each part X and Y control the various ports at the appropriate time, and the action of one of said valve devices will always be absolutely independent of the condition or action of the other valve device. In other words, the valves 2 and 3 (part X) being set to obstruct the air-passages 7 8, which said valves control, and valves 2' 3' (part Y) permitting the passage-ways, which they control to be open, then the valve device of part X must act as a differential valve device, as previously set forth herein, while the valve device of part Y will act in the manner hereinbefore set forth, describing the operation of a single valve device. In making either a gradual stop or an emergency stop the engineer's valve is manipulated in exactly the same manner as when controlling the Westinghouse system, that being the same manner in which my present single valve device is controlled. In making the gradual stop the valve device in part Y controls the air-pressure necessary to make the stop and acts as previously set forth herein. In the meantime the valve device in part X will remain quiescent for the reasons already set forth herein.

When an emergency stop is to be made, air is discharged from the train-pipe, thereby reducing the pressure about twenty pounds. The preponderance of air-pressure will then be on the auxiliary-reservoir side of both of said valve devices. Therefore they will immediately move toward the right to the ends of their paths. This will open five paths through which the air-pressure will travel to reach the brake-cylinder. The said paths are as follows: The train-pipe discharges into the brake-cylinder through ports 15 in both valve devices, and thence through ports 23 to the brake-cylinder. Another path leads from openings 30 (in both valve cases) through ports 27 and 26 (part X) to the brake-cylinder, and a fifth path leads from opening 30 (part Y) through passage 7, valve 2', around to port 24, thence through valve 3' to the brake-cylinder. To release the brakes, air is admitted as previously described, and the valve devices will move to their normal position to the left, at which time the air confined in the brake-cylinder escapes through one outlet only—viz., through passage 8', valve 3', restricted port 24, and exhaust-port 25. The partition E in part X is exposed to the atmosphere through vent 1. It will be observed from the foregoing description that if one of the valve devices failed to perform its work the other device would act promptly. This is because the train-pipe pressure and the auxiliary-reservoir pressure act upon the pistons of said valve devices simultaneously, independently, and differentially. From the explanation herein set forth it will be noted that I may use one of said parts (X or Y) for gradual stops, while the other part may be used for quick action or emergency stops only. Either part X or Y (when arranged as illustrated in Figs. 7 and 8) may be transformed at will by means of handle 4 from a graduation valve device to an emergency valve device, and vice versa.

I do not limit my invention to any particular kind or shape of valve.

I am aware that it has been proposed to control the direct or emergency communication between the train-pipe and the brake-cylinder by means of a supplemental valve and piston which is unconnected with the main-valve piston, but upon the movement of which said supplemental piston (to obtain motion) must depend for a supply of air-pressure, and such construction, which involves an operation and arrangement different from that of my invention, I therefore hereby disclaim.

What I claim is—

1. In an air-brake system, the combination of a train-pipe having a direct communication with two adjacent piston or valve chambers, a communication between an auxiliary reservoir and a brake-cylinder, a communication between the train-pipe and the brake-cylinder, a restricted exhaust-passage between the brake-cylinder and the atmosphere, a valve device in one of said chambers and adapted

to control said exhaust and also admit air from the auxiliary reservoir to said brake-cylinder when such valve device is in its normal condition, and a normally inert valve device in the remaining or second of said chambers and adapted to admit air-pressure sufficient to apply the brakes independently of the condition of the first-mentioned valve device in an emergency application, the said restricted exhaust being adapted to restrict the escape of air from the brake-cylinder if the first-mentioned valve device should fail to close the exhaust when an emergency-brake application is made.

2. In an air-brake system, the combination of a passage from the train-pipe, a passage from the brake-cylinder which is smaller or more restricted than said train-pipe passage, and a valve device, consisting of a valve connected with a ported piston, coacting with both of said passages and controlling communication between said train-pipe passage and the auxiliary reservoir and also between said brake-cylinder and the exhaust whereby when it is desired to release the brakes, the train-pipe air will have a passage through said ported piston and thence through a large passage-way to the auxiliary reservoir, the brake-cylinder air will have a passage-way through a valve-controlled restricted passage to the atmosphere.

3. A valve apparatus for automatic air-brakes, having in combination two ports or passages communicating with the brake-cylinder, one of said passages being small and from the auxiliary reservoir and the other a large passage from the train-pipe, so that the flow of auxiliary-reservoir air is restricted as compared with the flow of train-pipe air when both are flowing to the brake-cylinder during an emergency brake action, a ported piston actuated in both directions by air-pressure, a stem having one end suitably connected with said piston, and a suitable valve operated by said stem to open and close the passage from the auxiliary reservoir while said piston controls the valved passage from the train-pipe to the brake-cylinder and opens the same for emergency stops only.

4. In an air-brake system, the combination of a passage from the train-pipe, a passage from the auxiliary reservoir which is smaller or more restricted than said train-pipe passage, and a valve device consisting of a valve which is mechanically connected to and moved in both directions by a ported piston, the said valve device coacting with both of said passages and controlling communication between them and the brake-cylinder whereby, when an emergency application of the brakes is desired the train-pipe air and the auxiliary-reservoir air, the former at a lower pressure than the latter, will both have passages open to the brake-cylinder as follows: said train-pipe air-passage being through said piston and thence through a by-path in the valve-case, the said auxiliary-reservoir

air-passage being through another path in the valve-case and controlled by said valve.

5. A valve mechanism for automatic air-brakes having in combination, a passage leading to the brake-cylinder from the train-pipe, a passage leading to the brake-cylinder from the auxiliary reservoir, which is smaller or more restricted than said train-pipe passage, a ported piston actuated in one direction, by pressure from the train-pipe to close said train-pipe passage, and actuated in the opposite direction by pressure from the auxiliary reservoir to open said train-pipe passage, a stem having one end suitably connected with said piston, and a valve suitably connected with said stem and moved thereby to control said passage between the auxiliary reservoir and the brake-cylinder, while said piston controls the passage between said train-pipe and the brake-cylinder and opens said passage for emergency stops only.

6. In an automatic air-brake system, the combination, with the train-pipe, an auxiliary reservoir, and a valve device, of a second valve device which is adapted to act absolutely independent of the action or inaction of the first-mentioned valve device and only when emergency brake applications are made, both of said valve devices being adapted to admit air from the auxiliary reservoir to brake-cylinder, and a passage from said train-pipe to said brake-cylinder, and controlled by said second valve device.

7. In an air-brake system, the combination of a train-pipe, two valve devices communicating therewith, the piston parts of both of said devices being constantly under the train-pipe air-pressure and each of said devices being adapted to operate absolutely independent of either the action or inaction of the other and each of such devices being adapted to control a passage leading from the auxiliary reservoir to the brake-cylinder.

8. In an air-brake mechanism, the combination of a train-pipe having a connection to a valve-device chamber or casing, a communication between said chamber or casing and an auxiliary reservoir, a communication between said chamber or casing and a brake-cylinder, and a normally inert differential piston-valve device located within said chamber or casing and adapted to act when making emergency stops only, and establish a check-valved communication between said train-pipe and said brake-cylinder, the piston of said valve device being actuated by auxiliary-reservoir air-pressure in one direction to open or establish the latter communication, and moved by train-pipe air-pressure to cut off or close said communication, during such movements said device operating free from any other valve device.

9. In an air-brake system, the combination of a train-pipe, an auxiliary reservoir, a brake-cylinder, two valve devices adapted to act absolutely independent of each other, air communication between said train-pipe and

the auxiliary reservoir, air communication between said train-pipe and said brake-cylinder, air communication between said auxiliary reservoir and said brake-cylinder and a restricted air-passage between said brake-cylinder and the atmosphere, each of said valve devices being adapted to influence the air movement from said auxiliary reservoir to said brake-cylinder, one of said valve devices operating only during emergency applications of the brakes.

10. In an air-brake system, the combination of a valve device, substantially as described, having a ported piston mechanically connected with a valve, a chamber or case for said piston, a chamber for said valve, a passage from the train-pipe to said piston-chamber, a passage from said piston-chamber to the auxiliary reservoir, a passage from said piston-chamber to the brake-cylinder, a restricted passage from said auxiliary reservoir to the brake-cylinder, and a restricted passage from said brake-cylinder to the exhaust-opening, the said piston when at one end of its cylinder forms a part of a communication between said train-pipe and said auxiliary reservoir, said valve in the meantime forming a part of a communication between said brake-cylinder and said exhaust-opening, but when said piston is at the other end of its cylinder it becomes a part of a communication between said train-pipe and said brake-cylinder, said communication being open for emergency stops only, and said valve, in the meantime, opening a communication between the auxiliary reservoir and said brake-cylinder.

11. In an air-brake mechanism, the combination of a train-pipe having a tubular connection to two adjacent valve-device chambers or casings, a tubular connection from each of said chambers or casings to a brake-cylinder, a tubular connection from each of said chambers or casings to an auxiliary reservoir, a passage from the brake-cylinder to the atmosphere, a graduating-valve device located within one of said chambers or casings, and a normally inert differential piston-valve device located within the other chamber or casing, the latter valve device being adapted to operate when making emergency stops only, and control the communication between said train-pipe and said brake-cylinder, each piston of said valve devices being actuated by auxiliary-reservoir air-pressure in one direction to open or establish said communications and moved by train-pipe air-pressure in the opposite direction to close or cut off said communications, in operation said valve devices acting absolutely independent of each other.

Signed at New York, in the county of New York and State of New York, this 17th day of January, A. D. 1898.

GRANVILLE T. WOODS.

Witnesses:

E. RILEY,  
ORY CANE.