

Sept. 23, 1924.

1,509,145

H. C. HAUMUELLER

WHEEL TONGS

Filed Aug. 16, 1923

2 Sheets-Sheet 1

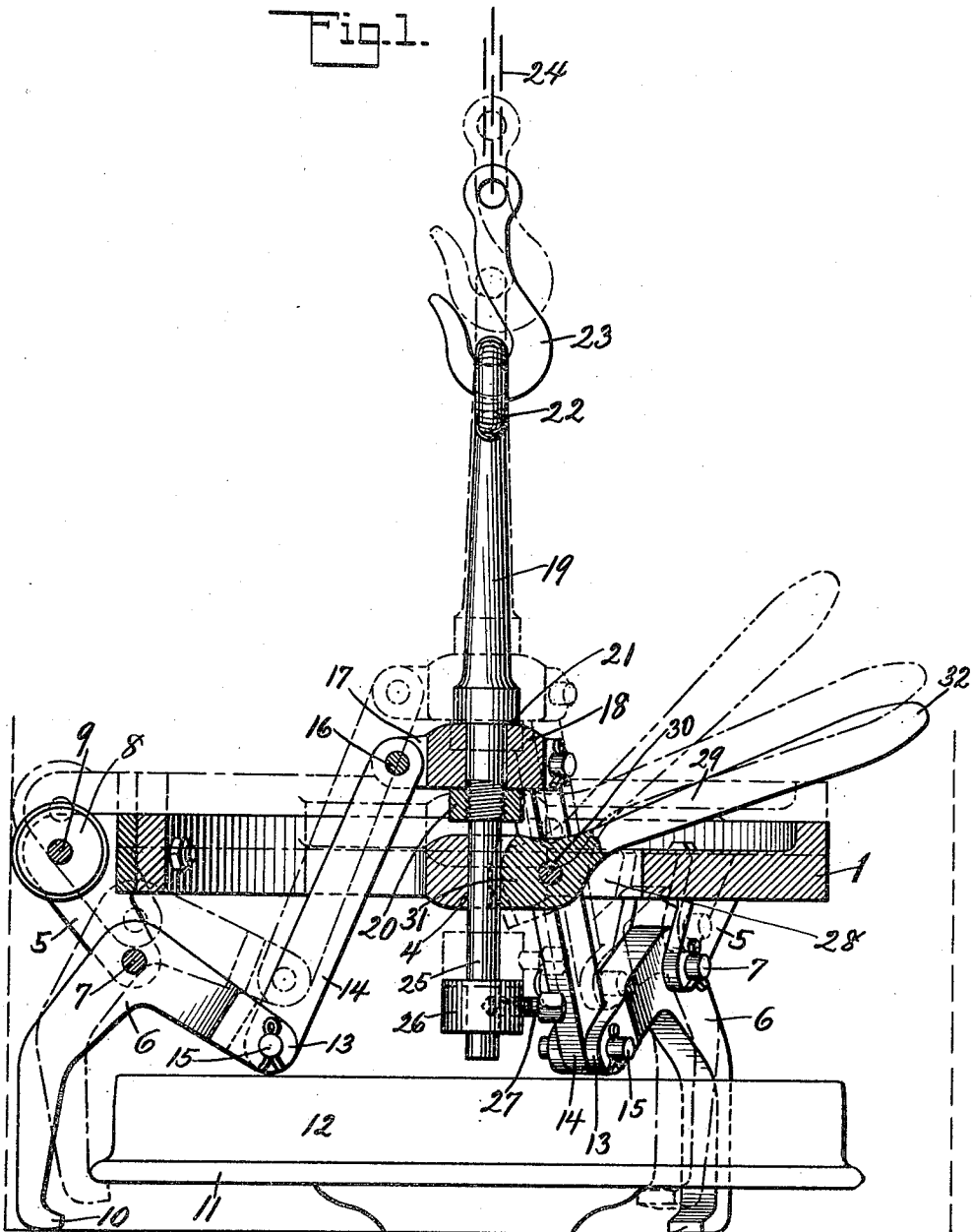

INVENTOR:
H.C. Haumueller
BY *F.H. Libes*
ATTORNEY.

Sept. 23, 1924.

H. C. HAUMUELLER

1,509,145

WHEEL TONGS

Filed Aug. 16, 1923

2 Sheets-Sheet 2

Fig. 2.

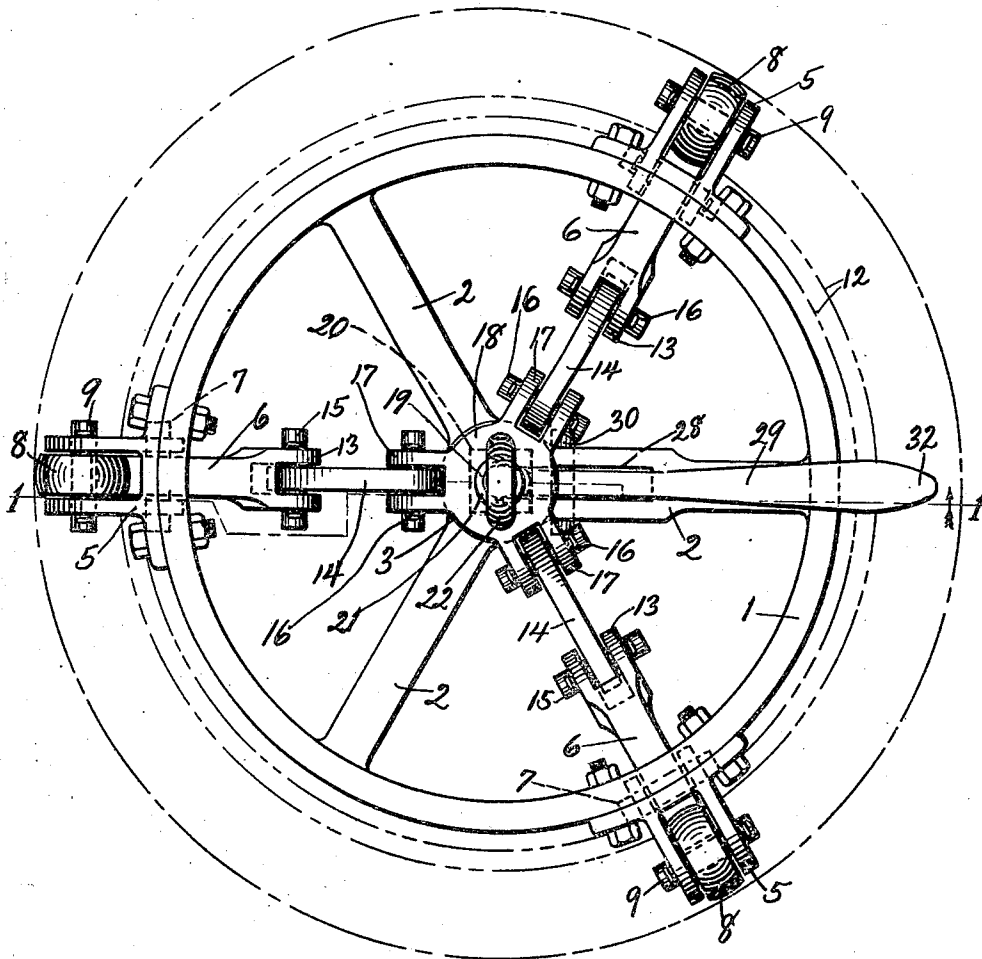

INVENTOR:
H. C. Haumueller
BY *F. H. Gibbs*

ATTORNEY.

UNITED STATES PATENT OFFICE.

HENRY C. HAUMUELLER, OF ST. LOUIS, MISSOURI, ASSIGNOR TO AMERICAN CAR AND FOUNDRY COMPANY, OF NEW YORK, N. Y., A CORPORATION OF NEW YORK.

WHEEL TONGS.

Application filed August 16, 1923. Serial No. 657,710.

To all whom it may concern:

Be it known that I, HENRY C. HAUMUELLER, residing at St. Louis, State of Missouri, and being a citizen of the United States, have invented certain new and useful Improvements in Wheel Tongs, of which the following is a full, clear, and exact description, such as will enable others skilled in the art to which it appertains to make and to use the same, reference being had to the accompanying drawings, which illustrate the preferred form of the invention, though it is to be understood that the invention is not limited to the exact details of construction shown and described, as it is obvious that various modifications thereof within the scope of the claims will occur to persons skilled in the art.

In said drawings:

Fig. 1 is a central vertical section of a wheel tongs constructed in accordance with this invention taken on the line 1—1 of Fig. 2 and showing the supporting and operating rod in elevation; and

Fig. 2 is a plan view of the same.

It is an object of this invention to provide an improved tongs of the character described which may be readily operated to engage and disengage a wheel and which may be locked in the disengaging or open position in order that it may be moved and readily engaged with another wheel.

As shown in the drawings the device comprises a ring member 1 having radial spokes or arms 2 which are united at the center by a hub 3 having an opening 4. Equally spaced about the ring 1 and bolted thereto are brackets 5 in which bell crank levers 6 are pivotally mounted on pins 7 and in which rollers 8 are mounted on pins 9. The bell crank levers 6 have their ends 10 inwardly bent to engage beneath the flanges 11 of wheels 12 while their other ends are bifurcated as at 13 to receive the ends of links 14 which are pivotally secured therein by pins 15. The upper ends of the links 14 are pivotally secured by pins 16 to the lugs 17 formed on a collar 18 secured on the supporting and operating rod 19 by a nut 20 which forces the collar 18 against a shoulder 21 formed on the rod 19.

The rod 19 is provided at its upper end with an eye 22 to receive the hook 23 attached by a chain 24 to a suitable hoisting device in the usual manner. The lower por-

tion of the rod 19 is of a reduced diameter as at 25 and is passed through the opening 4 in the hub 3 and has a collar 26 below the hub 3 secured thereon by a set screw 27. One of the spokes or arms 2 is slotted as at 28 and has a weighted cam lever 29 pivotally mounted therein on a pin 30. The lever 29 has a cam portion 31 which is adapted to engage with the portion 25 of the rod 19 and has a handle portion 32 which is of sufficient weight to bring the cam portion 31 of the lever 29 into engagement with the portion 25 of the rod 19 when released.

In operation, when it is desired to engage the tongs with a wheel the handle portion 32 is raised, disengaging the cam portion 31 from the portion 25 of the rod 19 so that when the tongs are lowered the inwardly projecting ends 10 of the bell crank levers 6 will be separated permitting the tongs to pass over the wheel 12. With the bell crank levers in the position shown in solid lines in Fig. 1 and the lever 29 held in raised position, then raising the rod 19 will actuate the levers 6 through the links 14 bringing the inwardly turned ends 10 of the levers 6 beneath the flange 11 of the wheel 12. With the ends 10 in engagement with the flange 11, the load of the wheel 12 is transmitted through the lever 6 and links 14 to the rod 19 and at the same time the pull on the levers 6 through the links 14 and rod 19 tends to force the ends 10 into engagement with the flange 11 thereby securely holding the wheel. With the wheel in position in the tongs, the lever 29 may be released.

To disengage the levers 6 from the wheel 12 the tongs are lowered until the wheel rests on the ground or some support, the lever 29 is raised and the tongs are lowered, permitting the levers 6 to become disengaged from the wheel 12. The lever 29 is then released, bringing the cam portion 31 into engagement with the portion 25 of the rod 19. Raising the rod 19 will then cause the cam 31 to bind against the portion 25 forcing the portion 25 against the hub 3 and preventing movement of the portion 25 of the rod 19 through the hub 3 and also preventing movement of the levers 6, thus retaining the levers 6 in the disengaging or open position. The strain of lifting the unloaded tongs is then transmitted from the portion 25 of the rod 19 through the cam 31 and hub 3 to the spokes 2 and the ring 1

and through the brackets 5 to the levers 6. Where the tongs are operated from a crane the lever 29 will be controlled by the crane operator by means of a connection extending
5 from the lever 29 to the cab of the crane.

In the modification, as shown in the drawings, the rollers 8 have been provided for engaging the sides of the wheel pits as the tongs are lowered into the pits to deposit
10 the wheels therein. It is to be understood that where the tongs are not used in connection with wheel pits, that the rollers may be omitted.

What is claimed is:

15 1. Wheel tongs comprising a ring member, bell crank levers pivotally mounted on said ring member, a rod for supporting said member and levers and links connecting an end of each lever to said rod.

20 2. Wheel tongs comprising a ring member, levers pivotally mounted on said ring member, arms projecting radially from said ring member, a rod for supporting said ring member and levers, links connecting said
25 rod and levers and means connecting said arms together and forming a guide for said rod.

3. Wheel tongs comprising a ring member, bell crank levers pivotally mounted on
30 said ring member, a rod for supporting said ring member and levers, a guide for said rod carried by said ring member and links connecting said levers to said rod.

4. Wheel tongs comprising a ring member, bell crank levers pivotally mounted on
35 said ring member, a rod for supporting said levers and ring member; links connecting said rod and levers, guide means for said rod carried by said ring member and auto-
40 matically operating locking means for said rod mounted on said guide means.

5. Wheel tongs comprising a ring member, bell crank levers pivotally mounted on
45 said ring member, a rod guided by said ring member, links connecting said rod and levers and means operative upon the upward movement of said rod to lock said rod with respect to said ring member.

6. Wheel tongs comprising a ring member, bell crank levers pivotally mounted on
50 said ring member, an operating rod for said

levers, means connecting said levers and rod to operate said levers upon raising and lowering said rod and means adapted to connect
55 said rod and ring member to prevent operation of said levers upon raising said rod.

7. Wheel tongs comprising a ring member, bell crank levers having wheel engaging portions and pivotally mounted on said
60 ring member, a rod, means connecting said rod and levers to operate said levers upon movement of said rod with respect to said ring member and a locking cam adapted to prevent movement of said rod with respect
65 to said ring member.

8. Wheel tongs comprising a ring member, bell crank levers pivotally mounted on
70 said ring member, a rod for supporting said ring member and levers, links connecting said rod and levers and adapted to operate said levers upon movement of said rod with respect to said ring member and means adapted to automatically connect said rod and said ring member upon movement of
75 said rod in one direction.

9. Wheel tongs comprising a ring member, bell crank levers pivotally mounted on
80 said ring member, an operating rod for said levers, guide means for said rod carried by said ring member, a collar fixed on said rod, links connecting the ends of said levers and said collar and automatically operating means carried by said guide means adapted
85 to hold said levers in disengaging position.

10. Wheel tongs comprising a ring member, bell crank levers pivotally mounted on
90 said ring member and having inwardly projecting wheel engaging portions, a rod for supporting said ring member and levers, means connecting said rod and levers to engage and disengage said levers as said rod is raised and lowered, a locking cam adapted to hold said levers in disengaging position as said rod is raised and guiding rollers
95 mounted on said ring member.

In witness whereof I have hereunto set my hand in the presence of two witnesses.

HENRY C. HAUMUELLER.

Witnesses:

GEORGE W. MITSCH,
ORVILLE H. HAUMUELLER.