

Jan. 17, 1933.

C. H. FOLMSBEE

1,894,679

DOME RING FOR WELDED TANKS

Filed June 4, 1931

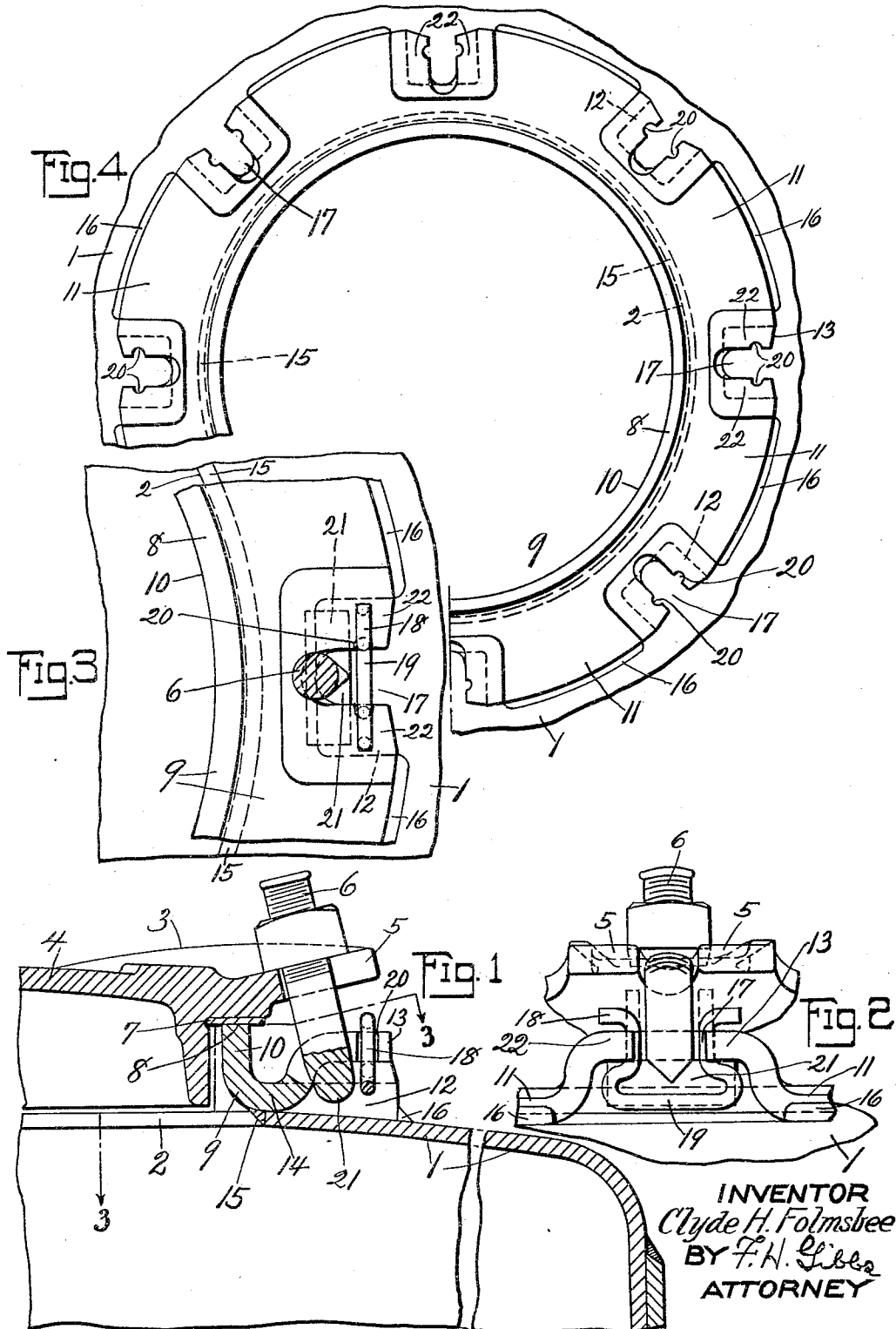

UNITED STATES PATENT OFFICE

CLYDE H. FOLMSBEE, OF CRANFORD, NEW JERSEY, ASSIGNOR TO AMERICAN CAR AND
FOUNDRY COMPANY, OF NEW YORK, N. Y., A CORPORATION OF NEW JERSEY

DOMED RING FOR WELDED TANKS

Application filed June 4, 1931. Serial No. 542,002.

This invention relates generally to closure devices for tanks, containers or other receptacles and more particularly to an improved dome ring for car tanks.

It is desirable wherever possible to reduce the cost of tank cars without jeopardizing the durability and safeness of the tank construction. It is of course most essential that detailed features of the tank should be strongly built not only because of the severe treatment to which they are subjected, but also in view of the transportation of inflammable liquids such as gasoline, which requires maximum safety, this safety being accomplished in part by eliminating leakage as far as possible. One point of the tank car at which care must be taken in order to insure safety and durability is the dome. It is here that the workmen are exposed to maximum danger, and in addition the workmen quite often subject the dome to severe treatment as by prying off a stuck down cover with a crowbar.

It is an object of this invention to provide an improved dome which will combine safety and durability with a less expensive construction.

Another object is to provide specifically an improved plate steel dome ring which will have the advantages of prior cast ring constructions and yet will have a high degree of simplicity and rigidity of construction and be effective in preventing leakage.

A further and more specific object is to provide an improved dome ring of pressed plate steel which is so constructed and arranged that the bolts for the cover may be effectively supported by the flange of the ring and yet will not set up destructive strains or stresses within the plate metal dome ring.

A still further object is to so shape the ring and have it associated with the tank in such a manner as to permit securing of the ring to the tank walls by a simple and yet effective weld.

A further and more specific object is to provide such a form of plate steel dome ring that is may be effectively welded with a minimum of welded surface and of maximum

strength notwithstanding that the flange of the ring is arranged to support the cover bolts and permit complete removal thereof. In this respect it is a further and more specific object of the invention to provide improved means for removably supporting the holding bolts.

Other objects and advantages will be more apparent to those skilled in the art from the following description of the accompanying drawing in which,

Fig. 1 is a fragmentary vertical section through the tank and dome.

Fig. 2 is a partial side elevation looking toward the bolt from the right in Fig. 1.

Fig. 3 is a plan view of Fig. 1, and

Fig. 4 is a partial plan view of the dome ring.

In the drawing there is shown, merely for the purposes of illustrating one specific embodiment which the invention may take, a tank or other receptacle 1 having a dome opening 2 covered by a dome generally indicated at 3. The dome cover 4 is of any usual construction having ears 5, adapted to receive pivoted bolts 6. The cover is, as usual, provided preferably with a gasket 7, resting upon the seating surface 8 of the improved dome ring 9.

The dome ring as shown herein is of relatively heavy plate metal such as might be used for the tank wall, adapted to be pressed by dies into desirable configuration as shown herein. The ring comprises the usual cylindrical part 10 and a flange 11 which is of annular form except for regularly spaced pockets or recesses 12. These pockets are formed by pressing portions 13 of the flange upwardly along a limited circumferential and radial extent thereby permitting a substantial portion of the flange 11 to remain in engagement with and conform to the upper surface of the tank wall and of also permitting the inner curved part 14 of the ring to have uniform contact around the entire circumference of the opening 2. It will be noted that approximately the center of the curved part 14 is disposed over the edge of opening 2 thereby allowing the cylindrical portion 10 to extend inwardly of said edge. Due to the

construction just described the ring can be effectively welded to the tank on the inside as at 15 the welding seam extending around the entire circumferential edge surface of the opening. By thus utilizing this edge surface there is provided a simple manner of creating a large surface area on the tank to which the weld may be made without involving any overhanging or protruding edges or other complications and at the same time the welded seam is strongly and directly secured to the dome ring. In addition the outer circumferential edge of flange 11 is welded as at 16 to the tank between each of the pockets 12.

The pockets as shown are of sufficient vertical depth to permit free reception of the head 21 of the T-bolts 6, the shank of the bolts being received through an open end slot 17 which is narrower than the pocket thereby providing overhanging portions 22 to engage the T-bolt heads and resist upward pull of the bolts when the cover is tightened. To permit ready and easy removal of the bolts in case the bolt threads should become damaged or stripped a cotter pin 18 is provided. This cotter pin has its elongated head 19 disposed preferably within the pocket to engage the T-bolt heads thus preventing the bolt from dropping out. The cotter pin legs are disposed in semicircular or other suitably shaped recesses 20 formed in the edges of slots 17. While any suitable form of bolt retaining means might be employed to close the pocket it is preferable to have some cotter pin arrangement as shown, as cotter pins are relatively inexpensive and can be renewed when the bolt is replaced. The cotter pin may be of resilient material so as to be snapped into position or it may be sufficiently pliable to permit bending the ends of the legs downwardly from the dotted line position shown in Fig. 2. It will be noted that the legs of the cotter pin when disposed in the recesses 20 provide sufficient clearance, Fig. 2, for the bolt shank to swing out through the open end of slot 17 and thus permit removal of the dome cover.

It is thus seen that there is provided not only a very simple dome ring construction and method of securing the same to the tank, but of also providing a relatively simple arrangement for replacing the cover bolts.

From the foregoing description it will of course be clear to those skilled in the art that various changes may be made without departing from the spirit of the invention as set forth in the appended claims.

What is claimed is:

1. The combination comprising a tank having an opening and a plate metal dome ring provided with a cylindrical portion and an annular flange secured to the outer surface of the tank wall adjacent said opening, said flange having pressed out portions extended away from the surface of the tank wall to

provide bolt pockets, and bolts disposed in said pockets and projecting outwardly therefrom.

2. The combination comprising a tank having an opening, a plate metal dome ring having a cylindrical portion and an annular flange resting upon the outer surface of the tank wall adjacent said opening, said flange having portions extended away from the surface of the tank wall to provide pockets, open end slots in said extended portions communicating with said pockets, and bolts having shanks passing through said slots and heads receivable in said pockets.

3. The combination comprising a tank having a dome opening, a plate metal dome ring having a cylindrical portion and an annular flange engaging the outer surface of the tank wall adjacent said opening, said flange having portions extended away from the surface of the tank wall to provide pockets, open end slots in said extended portions communicating with said pockets, bolts having shanks passing through said slots and heads receivable in said pockets, and welding seams between said flange and the walls of said tank.

4. The combination comprising a tank having a dome opening, a plate metal dome ring having a cylindrical portion and an annular flange engaging the outer surface of the tank wall adjacent said opening, said flange having portions extended away from the surface of the tank wall to provide pockets, open end slots in said extended portions communicating with said pockets, bolts having shanks passing through said slots and heads receivable in said pockets, and removable means for retaining the bolts in said pockets.

5. The combination comprising a tank having a dome opening, a plate metal dome ring having a cylindrical portion and an annular flange engaging the outer surface of the tank wall adjacent said opening, said flange having portions extended away from the surface of the tank wall to provide pockets, open end slots in said extended portions communicating with said pockets, bolts having shanks extending through said slots and heads receivable in said pockets, and removable means for engaging the bolt heads in said pockets to prevent removal thereof but permitting swinging movement of the bolts through the open end of said slots.

6. A tank having a plate metal dome ring welded thereto, said dome ring comprising a dome cover receiving portion and an outwardly extending flange, parts of which are welded to the tank walls and other parts of which are spaced therefrom to form in association with said walls a plurality of bolt receiving pockets.

7. A dome ring for car tanks comprising a substantially circular pressed metal structure having a vertically arranged cover supporting flange and a circumferential attaching

flange provided with integral slotted raised portions constituting bolt receiving pockets.

8. A pressed metal dome ring having a vertical flange and a substantially horizontal attaching flange projecting therefrom provided with spaced upwardly projecting portions which define bolt receiving recesses, said portions being provided with axially directed slots.

9. A dome ring comprising a metal pressing having an annular vertically arranged flange and a substantially horizontal flange projecting therefrom and provided with a plurality of bolt receiving recesses pressed therein.

In witness whereof I have hereunto set my hand.

CLYDE H. FOLMSBEE.

20

25

30

35

40

45

50

55

60

65