

June 7, 1927.

1,631,306

A. A. CONSTANTINE

OPERATING MECHANISM FOR CAR VESTIBULE TRAP DOORS

Filed July 21, 1925

2 Sheets-Sheet 1

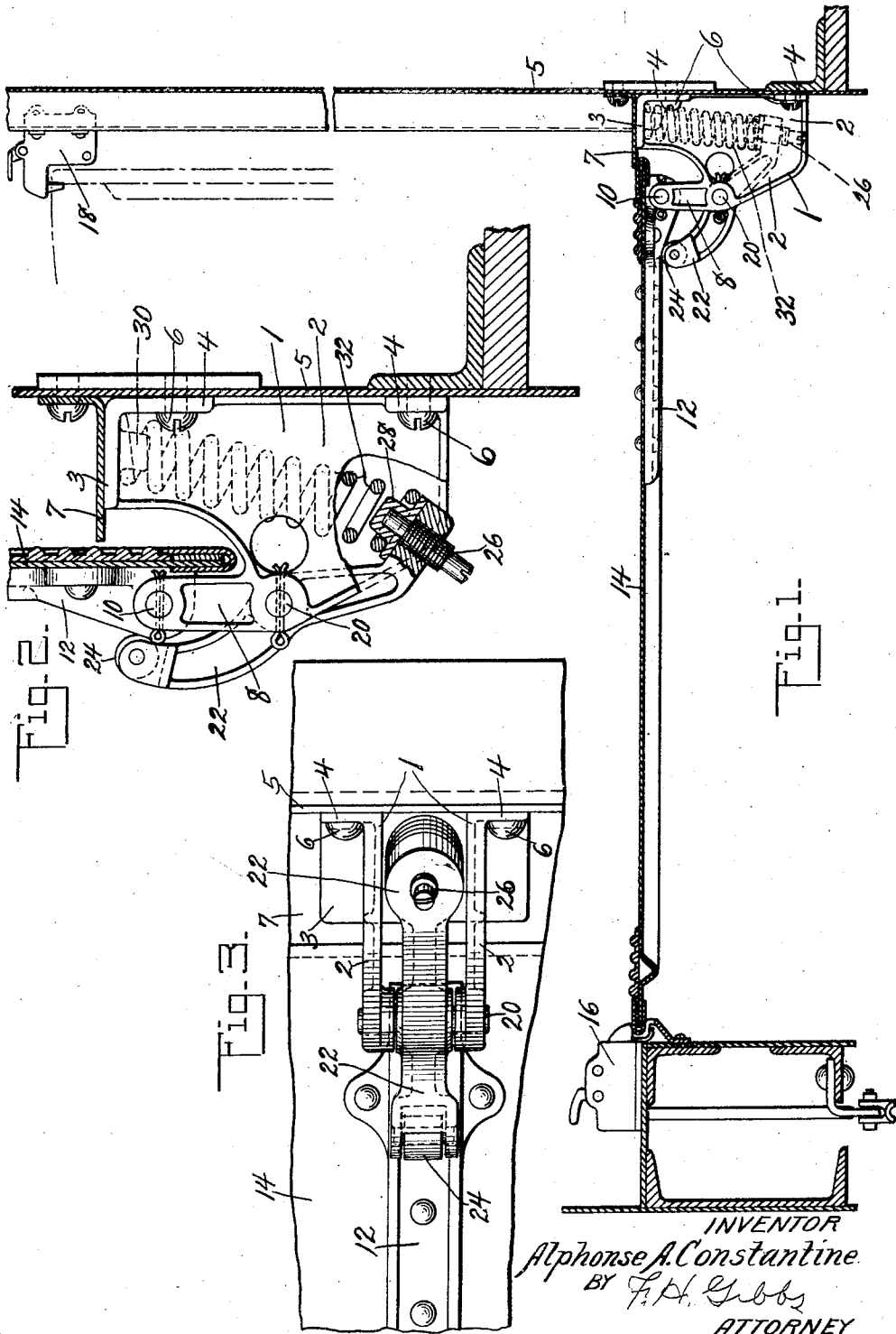

June 7, 1927.

A. A. CONSTANTINE

1,631,306

OPERATING MECHANISM FOR CAR VESTIBULE TRAP DOORS

Filed July 21, 1925

2 Sheets-Sheet 2

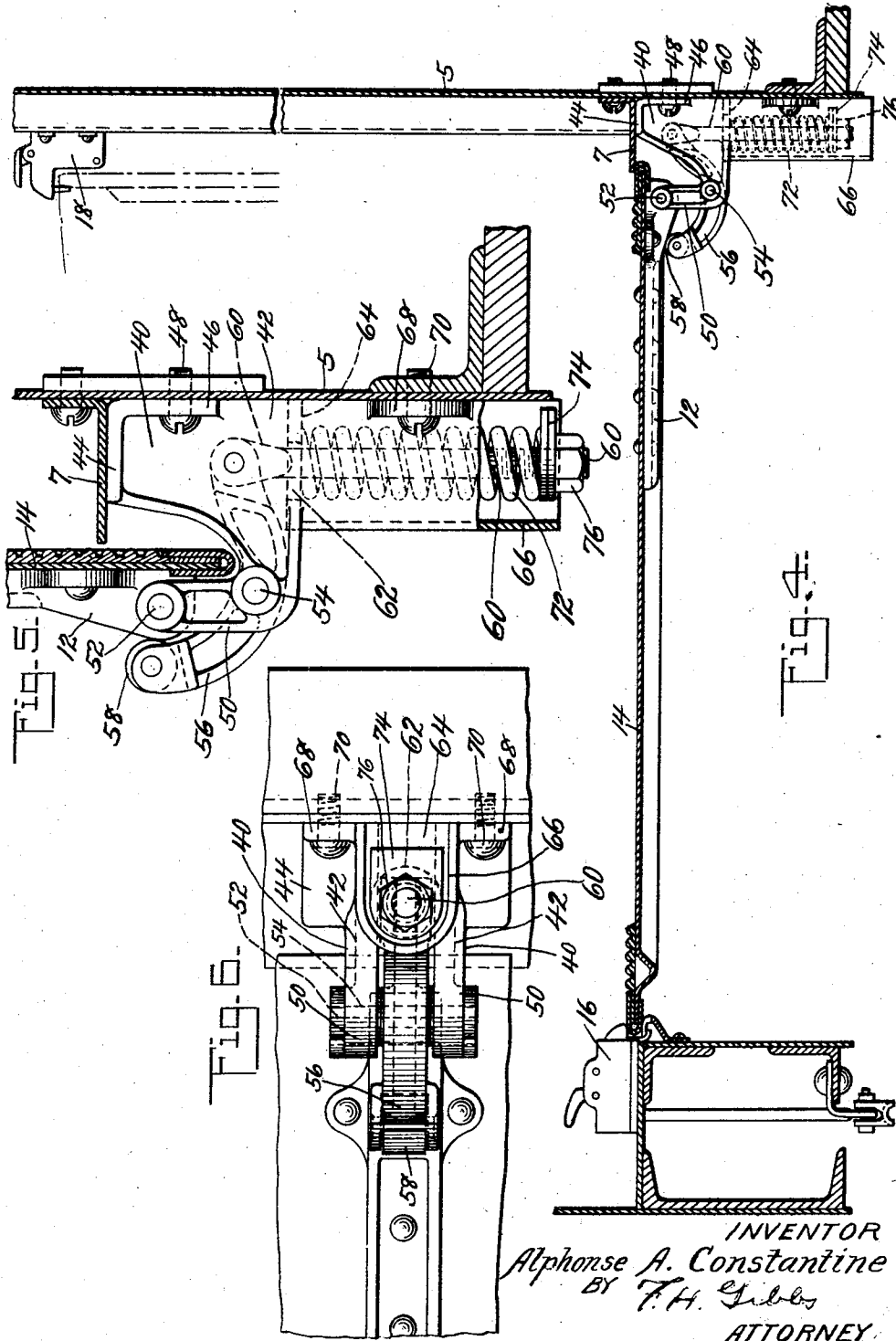

INVENTOR
Alphonse A. Constantine
BY F. H. Gibbs
ATTORNEY

Patented June 7, 1927.

UNITED STATES PATENT OFFICE.

ALPHONSE A. CONSTANTINE, OF JEFFERSONVILLE, INDIANA, ASSIGNOR TO AMERICAN CAR AND FOUNDRY COMPANY, OF NEW YORK, N. Y., A CORPORATION OF NEW JERSEY.

OPERATING MECHANISM FOR CAR-VESTIBULE TRAPDOORS.

Application filed July 21, 1925. Serial No. 45,092.

In the drawings:

Fig. 1 is a partial vertical section of a car vestibule showing a trap door equipped with an operating mechanism constructed in accordance with this invention, the door operating means being shown in elevation and the door in closed position;

Fig. 2 is a view in elevation, drawn to a larger scale, of the door operating mechanism in Fig. 1, the door being shown in raised position and parts being broken away to show other parts more clearly;

Fig. 3 is a bottom plan view of the door operating mechanism shown in Fig. 1, the door being shown in closed position, and

Figs. 4, 5 and 6 are views similar to Figs. 1, 2 and 3, respectively, showing a door operating mechanism of modified construction.

This invention relates to operating means for the trap doors of car vestibules and has for an object to provide an improved mechanism of the class described which shall be rugged in construction and reliable in operation and which shall consist of few simple parts which may be readily assembled. It is also an object of this invention to provide a mechanism of the class described in which the door operating lever is mounted on the hinge bracket and the door operating spring so confined between the hinge bracket and the door operating lever that the individual mechanisms form convenient units for shipment and handling and may be applied as a unit. It is also an object of this invention to provide mechanism of the class described in which the door operating lever and spring are shielded by the hinge bracket.

With these and other objects in view a door operating mechanism constructed in accordance with this invention comprises hinge brackets 1 at opposite ends of one edge of the vestibule trap door. Each hinge bracket is formed as a casting having spaced parallel flanged side members 2 joined at their tops by a cross piece 3 which projects beyond the side members 2. Each of the side members is provided at the top and bottom with attaching flanges 4 by which the brackets are secured to the car end walls 5 by suitable attaching means as bolts 6, the top attaching flanges being connected to the projecting portions of the cross piece 3. The hinge brackets are placed beneath the vestibule floor 7, fitting into the angle be-

tween the vestibule floor 7 and the end wall 5. While the hinge bracket has been shown as a casting, it is to be understood that it may be formed in any desired manner.

Each of the side members 2 is provided with an upwardly projecting door supporting arm 8, the door supporting arms being parallel and provided at their upper ends with openings in which are fitted pins 10. Pivotaly mounted on the pins 10 between the arms 8 of the hinge brackets 1 are the hinge straps 12 which are secured to the door 14 and secure the door 14 to the hinge brackets 1. As is usual with vestibule trap doors, the door is secured in its lowered position by a suitable locking and starting mechanism 16 such as is shown in my co-pending application, Serial No. 45090 filed July 21, 1925 and is held in its raised position by a suitable door holding means 18 such as is shown in my co-pending application, Serial No. 45091 filed July 21, 1925.

At the bottoms of the door supporting arms the hinge bracket sides 2 are provided with openings to receive a pin 20 upon which the door operating lever 22 is pivotally mounted between the sides 2 of the hinge bracket. At its outer end the door operating lever 22 is provided with a roller 24 which contacts with the hinge strap 12. At its inner end the door operating lever 22 is provided with a threaded opening in which is mounted a threaded pin 26 carrying a cap 28, the pin providing a means by which the position of the cap 28 with respect to the lever 22 may be adjusted. Engaging the adjustable cap 28 and a boss 30 formed integral with the cross piece 3 and positioned between the sides 2 of the hinge bracket is a door operating spring 32, the tension of which may be varied by adjusting the position of the cap 28. In this construction it will be noted that the spring 32 and the inner portion of the lever 22 are positioned between the sides 2 of the hinge bracket so that the lever and spring are shielded by the sides of the hinge bracket. It will also be noted that, with the pin 10 in position in the arms 8, the upward movement of the lever 22 is limited even though a door is not secured to the pin 10 so that the spring 32 will be held in position by the cap 28 and boss 30 thus permitting the device to be assembled for shipment or applied to the car as a unit.

In the modified construction shown in Figs. 4, 5 and 6 the hinge bracket 40 comprises spaced parallel flanged sides 42 secured together at their top by the cross piece 44 and having flanges 46 by means of which any suitable securing means as screws 48 secure the bracket to the end wall 5 of the car. As in the previous construction, the hinge brackets are secured beneath the vestibule floor 7 and in the angle between the floor 7 and end wall 5. The hinge brackets are provided with parallel upwardly projecting arms 50 having openings at their upper ends in which is mounted a pin 52 upon which a hinge strap 12 secured to the door 14 is pivotally mounted between the arms 50 as in the other construction. At the bottoms of the door supporting arms 50 the sides 42 are provided with openings to receive the pin 54 upon which the door operating lever 56 is pivotally mounted between the sides 42 of the hinge bracket. The lever 56 is provided at its outer end with a roller 58 which engages with the hinge strap 12 and has its inner end pivotally connected to a rod 60 which projects through an opening 62 in the bottom wall 64 connecting the sides 42 of the hinge bracket. Projecting from the bottom wall 64 is the U-shape extension 66 having attaching flanges 68 and secured by screws 70 to the end wall of the car, the U-shape projection forming with the end wall of the car a tube into which the rod 60 projects. Mounted upon the rod 60 and bearing against the bottom wall 64 is a spring 72 held in compression by the washer 74 adjustably secured on the rod 60 by a nut 76. In this construction as in the other it will be noted that the hinge bracket shields the inner portion of the door operating lever 56 and the spring 72 and that the device may be assembled complete for shipment or for mounting on the car.

When placed in position on the car, the pin 26 or nut 76 is adjusted to place the spring 32 or 72, respectively, under compression when the door is in its raised or open position. Moving the door to the lowered or closed position will increase the compression of the spring so that when the door is released the spring will raise the door to a position in which it may be readily grasped for movement to the raised or open position.

What is claimed is:

1. In a trap door operating mechanism, a hinge bracket for the door, a door operating lever pivotally attached intermediate its ends to said hinge bracket and resilient means engaging said bracket and lever to normally urge the latter against the door to swing the door to open position.

2. In a trap door operating mechanism, a hinge bracket for the door, a door operating lever pivotally mounted on said hinge bracket,

operating means for said lever engaging said bracket and means for limiting the movement of said lever by said operating means when said bracket is detached.

3. In a trap door operating mechanism, a hinge bracket for the door having door supporting arms, a door operating lever pivotally mounted on said hinge bracket between said door supporting arms, operating means for said lever engaging said bracket and means for hinging a door in said door supporting arms, said hinging means serving to limit the movement of said lever by said operating means when said bracket is detached.

4. In a trap door operating mechanism, a hinge bracket for the door, a door operating lever pivotally supported intermediate its ends on said hinge bracket and a spring interposed between the bracket and one end of the lever to normally urge the lever against the door to elevate the same.

5. In a trap door operating mechanism, a hinge bracket for the door having door supporting arms, a door operating lever pivotally mounted between said arms, and a lever operating spring bearing against said hinge bracket.

6. In a trap door operating mechanism, a hinge bracket for the door, a door operating lever pivotally mounted on said hinge bracket, a lever operating spring bearing against said hinge bracket and means for positioning said spring with respect to said hinge bracket.

7. In a trap door operating mechanism, a hinge bracket for the door having door supporting arms, a door operating lever pivotally mounted between said arms, a lever operating spring bearing against said hinge bracket and means for positioning said spring with respect to said hinge bracket.

8. In a door operating mechanism, a hinge bracket having door supporting arms, a door operating lever pivotally mounted between said arms and a lever operating spring bearing against said hinge bracket, said hinge bracket shielding said spring.

9. In a door operating mechanism, a hinge bracket, a door operating lever carried by said hinge bracket and a lever operating spring bearing against said hinge bracket, said hinge bracket shielding said spring.

10. In a door operating mechanism, a hinge bracket, a door operating lever pivotally mounted on said hinge bracket, a lever operating spring bearing against said hinge bracket and means positioning said spring with respect to said hinge bracket, said hinge bracket shielding said spring.

11. In a door operating mechanism, a hinge bracket having door supporting arms, a door operating lever pivotally supported between said arms, a lever operating spring bearing against said hinge bracket and

means positioning said spring with respect to said hinge bracket, said hinge bracket shielding said spring.

12. A trap door operating mechanism comprising a hinge bracket for the door, a door operating lever pivotally mounted on said hinge bracket, operating means for said lever engaging said bracket and a pin for

hinging the door to said bracket mounted in said bracket and limiting the movement of said lever by said operating means when said bracket is detached.

In witness whereof I have hereunto set my hand.

ALPHONSE A. CONSTANTINE.