

Sept. 20, 1938.

J. M. KNIGHT ET AL

2,130,766

WALK-OVER SEAT MECHANISM

Filed Jan. 28, 1936

3 Sheets-Sheet 1

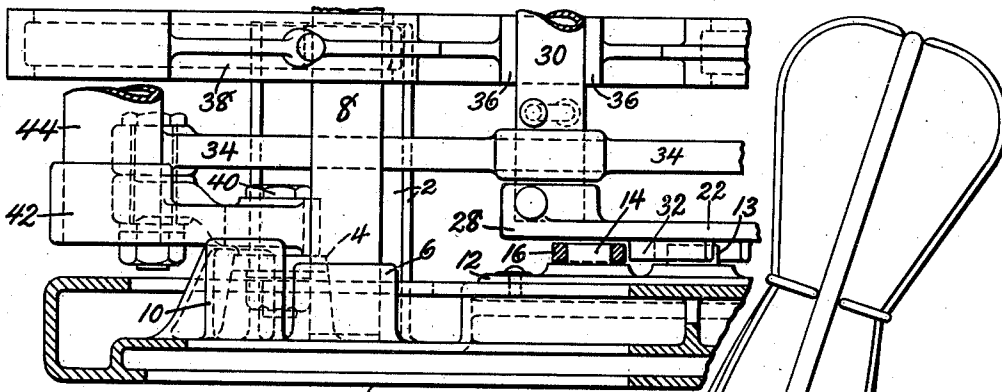

Fig. 3.

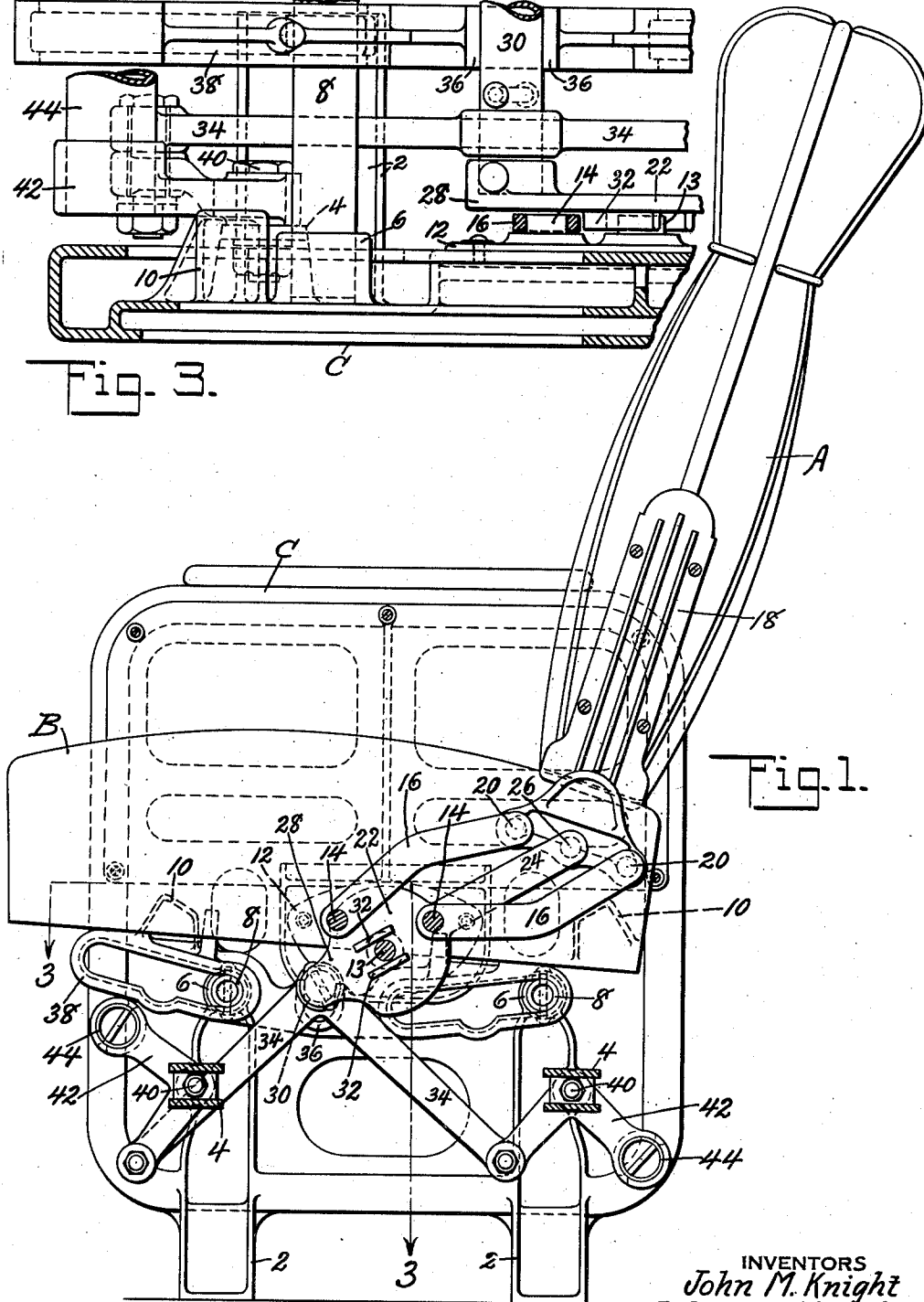

Fig. 1.

INVENTORS
John M. Knight
Julius Schlenker
BY *Ronald U. Rich*
ATTORNEY

Sept. 20, 1938.

J. M. KNIGHT ET AL
WALK-OVER SEAT MECHANISM

2,130,766

Filed Jan. 28, 1936

3 Sheets-Sheet 2

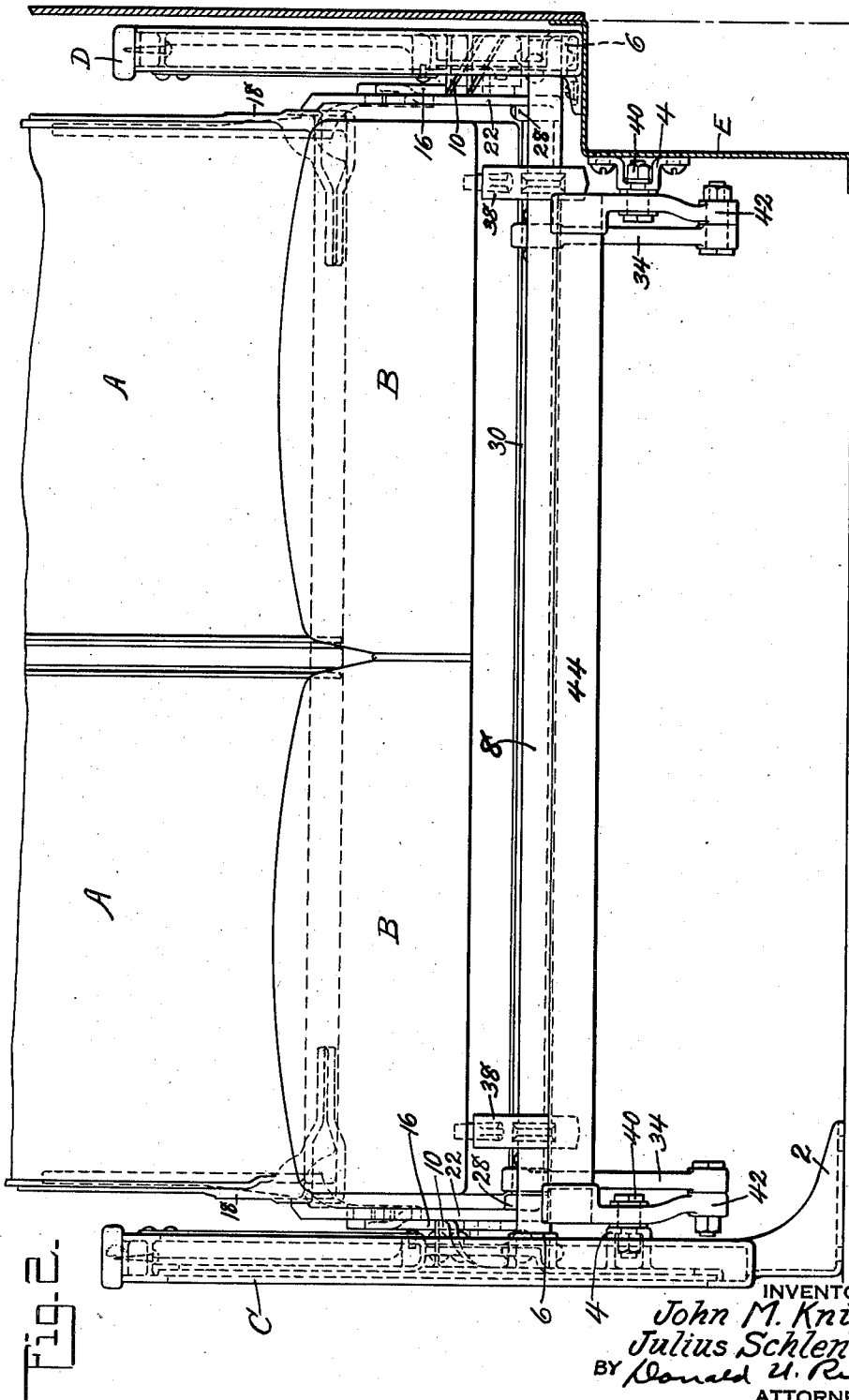

Fig. 2-

INVENTORS
John M. Knight
Julius Schlenker
BY *Donald U. Rief*
ATTORNEY

Sept. 20, 1938.

J. M. KNIGHT ET AL
WALK-OVER SEAT MECHANISM

2,130,766

Filed Jan. 28, 1936

3 Sheets-Sheet 3

Fig. 5.

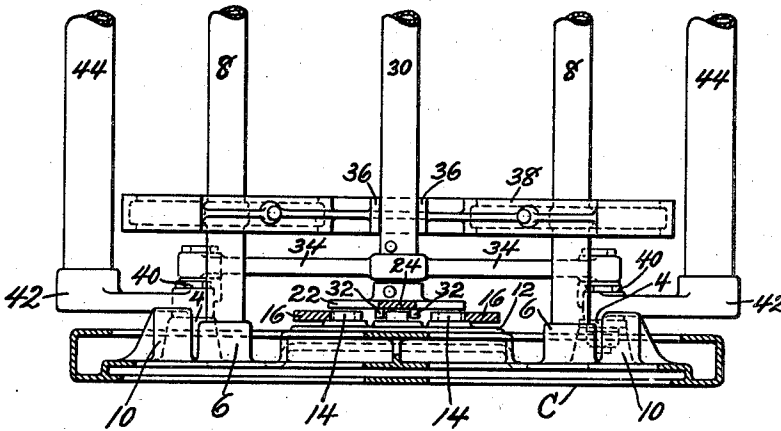
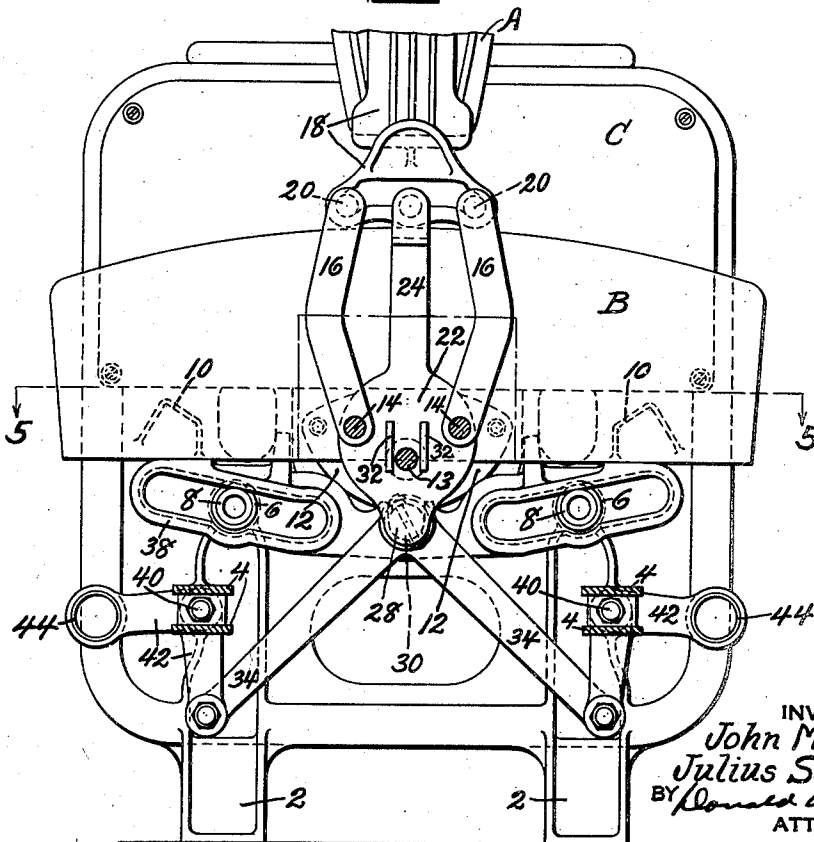

Fig. 4.



INVENTORS
John M. Knight
Julius Schlenker
BY *Donald H. Pich*
ATTORNEY

UNITED STATES PATENT OFFICE

2,130,766

WALK-OVER SEAT MECHANISM

John M. Knight, Atlantic Highlands, N. J., and
Julius Schlenker, St. Charles, Mo., assignors
to American Car and Foundry Company, New
York, N. Y., a corporation of New Jersey

Application January 23, 1936, Serial No. 61,122

5 Claims. (Cl. 155—102)

This invention deals with walk-over seats in general and in particular to walk-over seats with movable foot rests.

Previous walk-over seats have been provided with either fixed footrests which prevented the placement of baggage beneath the seat or with a movable footrest which was carried bodily from one side of the seat to the other during reversal of the seat. In this latter type baggage could be placed beneath the seat but it was necessary to remove this baggage before the seat could be reversed. The height of the seat also placed restrictions upon the position of the footrest for it was necessary that the arm carrying the footrest be short enough to permit reversal of the seat. It is an object, therefore, of this invention to provide a walk-over seat having movable footrests so operated as to permit reversal of the seat without disturbing objects beneath the seat.

Another object of the invention is the provision of a walk-over seat with movable footrests that may be readily placed in the desired position regardless of seat height.

A further object of the invention is the provision of a walk-over seat having footrests at either side of the frame which will be folded up or down in unison with the seat back movement.

A still further object of the invention is the provision of a walk-over seat having movable footrests positively operated by the seat back reversing mechanism.

These and other objects of the invention will be apparent to persons skilled in the art from a study of the following description and the accompanying drawings, in which:

Figure 1 is a sectional end view taken immediately adjacent the end standard and showing the controlling mechanism;

Fig. 2 is a front view of the seat unit applied to a car;

Fig. 3 is a sectional view of substantially one-half the seat and taken on line 3—3 of Fig. 1;

Fig. 4 is a view similar to Fig. 1 but showing the seat back and mechanism in the midway position, and

Fig. 5 is a sectional view of the seat mechanism taken on line 5—5 of Fig. 4.

Referring now to the drawings in detail, it is seen that the seat is formed with reversible back A and cushions B, suitably supported by aisle standard C and a wall standard D, which may be full length or supported upon heater casing E as shown. The standards, which are identical insofar as it is possible to make them so,

are formed with feet 2, bearing brackets 4 for the reception of the footrests, bearing portions 6 for the reception and securing of fixed cross rods 8, and seat back stops 10. Plates 12 may be formed as part of the standard but as shown are attached to the standard and provide a centrally located control pivot pin 13 and spaced pivot pins 14, the latter carrying links 16 pivotally connected to the seat back casting 18 at spaced points 20.

Control member 22 has one arm 24 pivotally connected as at 26 to the seat back casting, and has the other and oppositely extending arm 28 connected to movable cross or shifting control bar 30 which connects the control members on each standard. The control member has lugs 32 cast or otherwise attached thereto which engage the control pivot pin 13 to cause shifting of the cross control bar. The cross or shifting control bar 30 pivotally carries the diverging control arms 34, suitably held in place against the inner face of the hub of the control member 22 by pins as shown in Fig. 5, or by any other suitable means. This control bar 30 also engages between spaced wall portions 36 of sliding seat bars 38, the latter being carried by means of the cross rods 8 which extend through the elongated slots provided therefor in the seat bars.

The bearing brackets 4 may be, as stated, formed integral with the standards or attached to a suitable part of the car and these brackets support bolts or other pivot means 40 pivotally carrying bell-cranks 42, one end of which is connected to footrest bar 44, while the other end is pivotally connected to the respective control arm. The standards and various castings are preferably made of aluminum, although this is purely representative as any other metal may be used.

The operation of the seat is as follows: Assuming the parts to be in the position shown in Fig. 1, the seat back is moved counter-clockwise causing control member 22 to slide and rotate on control pin 13 and transferring control bar 30 from one side of the seat center plane to the other side. As the control bar shifts it causes the seat to change position in order that the seat may have the proper inclination and also through diverging control arms 34 cause the bell-cranks 42 on either side of the frame to rotate in opposite directions, thus raising one footrest and lowering the other. The links 16 operate during this rotation to change the seat back angle and in the final position one of the links will rest upon the back stop 10 checking any further movement of

the seat back. It is seen that the footrest on the front edge of the seat is carried high adjacent the cushion and that during reversal of the seat back the rest swings downward and outward for a portion of its movement then downward and inward for the remainder of its movement, thus insuring its clearing any baggage that may be under the seat. The movement of the footrest is such that for normal objects such as suitcases, even though lowering the rest contacts the object, it will move it to an out of the way position by sliding it along the floor.

The mechanism has been described in more or less detail, but it is obvious that modifications and rearrangements of parts will suggest themselves to persons skilled in the art and it is to be understood that such changes are contemplated as fall within the scope of the following claims.

What is claimed is:

1. A walk-over seat comprising, end frames, tie means connecting said frames, a seat back, a plurality of pivot pins projecting from the end frames, links connecting at least some of said pivot pins and seat back together, control means connected to said seat back and slidably engaging at least one of said pivots, a control bar connected to said control means and moveable therewith, bell-cranks pivotally mounted upon each of said frames, cross bars connecting said bell-cranks together in pairs to form footrests, and control arms pivotally connecting said bell-cranks to said control bar whereby said bell-cranks will be rotated in opposite directions upon movement of said control means by said seat back.

2. In a walk-over seat, end frames, a seat back, a control member pivotally guided by each end frame and pivotally connected to the seat back, footrest members pivotally supported by the end frames at opposite side edges of the seat, a control bar supported by the control member, and downwardly divergent control arms carried by the control bar and connected respectively with the footrest members to shift the latter on their piv-

ots upon movement of the seat back from one position to another.

3. A walk-over seat comprising end frames, a seat back, control members pivotally guided by each of said end frames and having oppositely directed arms, one of said arms being pivotally connected with the seat back, footrest members arranged along opposite sides of the seat, bell-crank levers pivoted to the end frames and supporting said footrest members, and operating means for said bell-crank levers pivotally connected to said other arm of the control members and bell-crank levers and operative upon pivotal movement of the control members to shift the bell-crank levers in opposite directions on their pivots to position the footrest members.

4. In a walk-over seat, end frames, a seat back, a control member pivotally engaging an end frame and pivotally connected to the seat back, footrest members pivotally supported by the end frames at opposite side edges of the seat, and downwardly divergent control arms pivotally connected with the control member and operatively connected respectively to the adjacent footrest members to shift the latter on their pivots upon movement of the seat back from one position to another.

5. A walk-over seat comprising end frames, a seat back link coupled to the frame, control members pivotally engaging said frames and having oppositely directed arms, one arm of each control member being pivotally connected to the seat back, a control bar connecting the other arms, footrest members arranged along opposite sides of the seat, bell-crank levers pivoted to the end frames and supporting said footrest members, operating means for the bell-crank levers pivotally connected to the control bar and bell-crank levers and operative upon pivotal movement of the control member to shift the footrests and their supporting bell-crank levers in opposite directions on their pivots.

JOHN M. KNIGHT.
JULIUS SCHLENTHER.