

Oct. 7, 1930.

E. A. RUSSELL

1,777,580

END TRAIN PIPE VALVE

Filed April 10, 1929

2 Sheets-Sheet 2

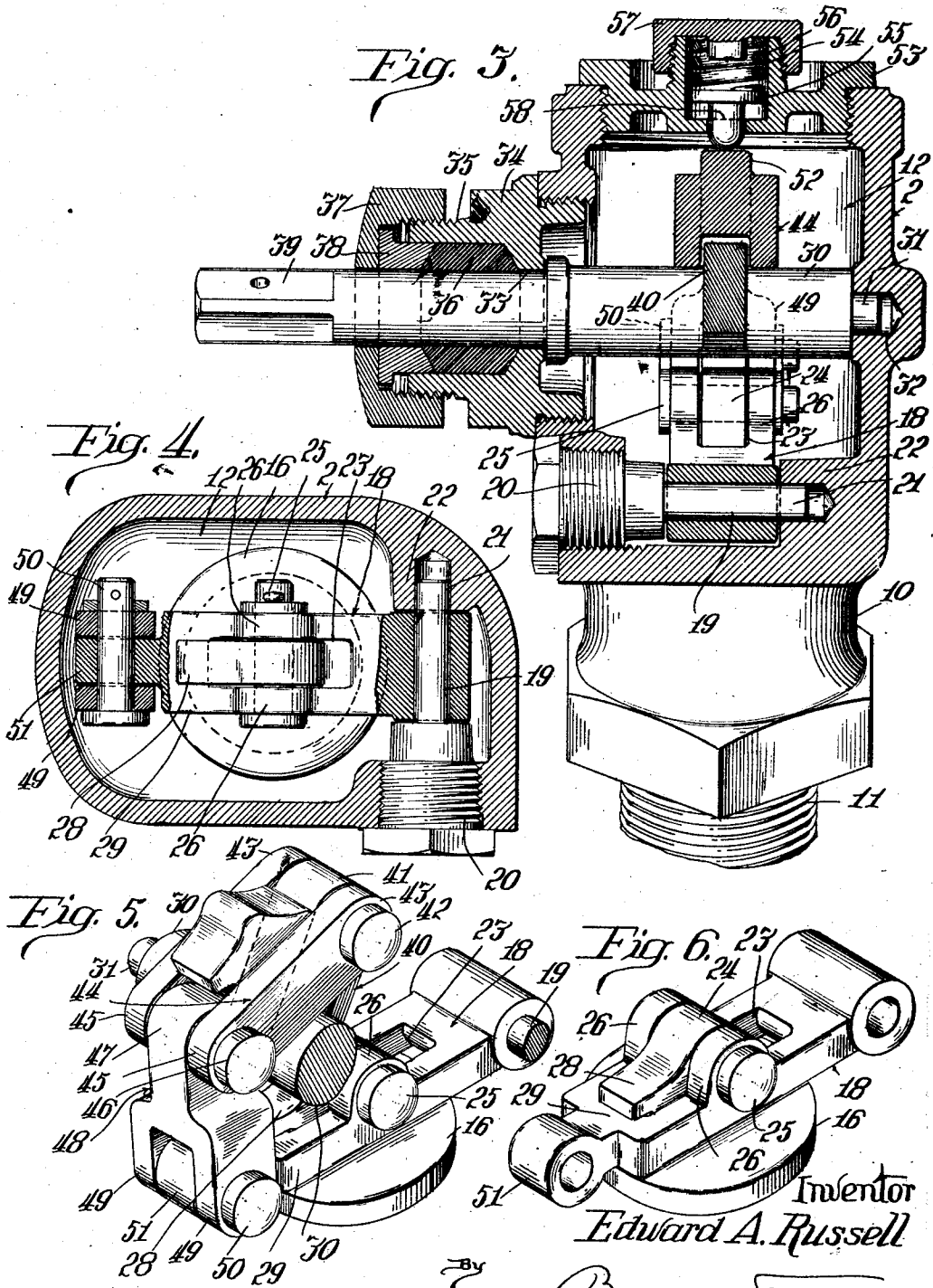

Inventor
Edward A. Russell

By
Barnett & Truman
Attorneys

UNITED STATES PATENT OFFICE

EDWARD A. RUSSELL, OF CHICAGO, ILLINOIS, ASSIGNOR TO VAPOR CAR HEATING COMPANY, INC., OF CHICAGO, ILLINOIS, A CORPORATION OF NEW YORK

END TRAIN-PIPE VALVE

Application filed April 10, 1929. Serial No. 354,130.

This invention relates to improvements in end train pipe valves for steam car-heating systems.

Systems of car-heating using steam from the engine are constructed with a train line or main supply pipe extending from the boiler head in the engine cab to the rear of the train. This train line is connected by steam couplers between the cars and is provided with branch steam connections to the heating pipes in each car. Each end of the train pipe on each car is provided with an end train pipe valve, these valves at the adjacent ends of two cars being normally open when these cars are included in a train and the steam couplings are in place and operatively connected. Only the end train pipe valve at the rear end of the train will be closed.

As the entire train line and connections are exposed to the weather, it follows that this pipe system contains considerable condensation. This condensation, if it is not allowed to discharge approximately as fast as it collects, will quickly freeze up and cause very serious trouble in cold weather. However, if the steam pressure is maintained on the train line all the way to the rear and the rear train pipe valve allowed to "bleed" a little steam through the rear hose connection, that is allow a small stream of steam to continuously escape, this common trouble will be avoided.

The object of the present invention is to provide an improved form of end train pipe valve adapted to satisfactorily perform the functions noted hereinabove, and disclosed more in detail in the specifications which follow.

Another object is to provide an improved form of valve opening and closing mechanism, adapted to exert a powerful leverage for breaking the valve from its seat, but compact and requiring comparatively little room within which to operate.

Another object is to provide an improved means for locking the valve in open position.

Other objects and advantages of this invention will be more apparent from the following detailed description of one approved form of the apparatus.

In the accompanying drawings:

Fig. 1 is a central vertical section through the valve, when in open position.

Fig. 2 is a similar view showing the valve closed.

Fig. 3 is a transverse section taken substantially on the line 3—3 of Fig. 1.

Fig. 4 is a transverse section taken substantially on the line 4—4 of Fig. 2.

Fig. 5 is a perspective view of the main portions of the valve operating mechanism, and

Fig. 6 is a perspective view of the assembled valve and valve-lifting lever.

Referring now to the drawings, at 1 is shown the end of the train steam pipe, supported in the usual manner beneath the car. The main casing 2 of the end train pipe valve is formed at the rear thereof with a pipe extension 3 forming in effect an extension of the train pipe 1. This extension 3 is provided at its open rear end with an integral collar 4, and a somewhat similar collar 5 is formed on or attached to the end of train pipe 1. An annular sealing flange 6 extends from the end of collar 5 and is adapted to engage within a corresponding annular groove formed in the end of collar 4, the beveled end of flange 6 engaging a packing ring or gasket 7 seated in the bottom of this groove. The collars 4 and 5 are preferably rectangular or of other non-circular outline, and the collars are secured together by a plurality of threaded bolts 8. By screwing up the nuts on these bolts 8, the engaging portions of the collars will be forced into steam-tight position, the joint being sealed by the gasket 7. The casing 2 has a second downwardly extending extending extension 10, in which is threaded the upper end 11 of the coupling through which connection is made with the adjacent car, or the end of a nipple by means of which this coupling is attached to the valve. The casing 2 houses the main steam chamber 12, into which steam flows through inlet port 13 in extension 3, and from which steam flows out through outlet port 14 into the coupling member 11.

The main valve seat 15 is screwed or otherwise mounted in the casing 2 at the entrance

to outlet port 14. The valve plate 16 is adapted to seat against the valve seat 15 and thus cut off the flow of steam through the valve, the valve plate being held in place by the steam pressure behind it. A small notch 17 formed in valve seat 15 permits a small quantity of steam to "bleed" through the valve, even though the valve is closed, this minute flow of steam being sufficient to keep the system full of steam and permit the discharge of condensate.

The valve operating lever 18 is fulcrumed at one end on the pivot pin 19, which has one larger outer end 20 screwed into one wall of casing 2, and its smaller inner end 21 journaled in a lug 22 formed in the opposite wall of the casing. The lever 18 extends transversely of the lower portion of chamber 12, directly behind the valve plate 16 and is formed intermediately with a central slot 23 through which projects the hinge lug 24 on the back of valve plate 16. A pivot pin 25 is mounted in a pair of ears 26 on the lever and projects loosely through an opening 27 in the lug 24 of the valve. This loose pivotal connection permits the valve to seat itself freely on the valve seat when the lever is swung downwardly. An extension 28 of valve lug 24 projects outwardly over the outer arm 29 of lever 18 so that when the lever 18 is swung upwardly, it will first engage this lug 28 and tilt the valve plate so as to break it away from its seat. It will be noted that the bleeding notch 17 is formed directly beneath lug 28 so that the valve will first be broken from its seat directly above this bleeding notch through which a small flow of steam already occurs. This will minimize the effort in breaking loose the valve. The position of notch 17 at the lowermost edge of the valve seat also permits condensate to drain from the valve chamber through this notch.

A rock shaft 30 extends transversely through chamber 12 above the valve and is journaled in the opposite side walls of casing 2. A reduced stud 31 on the inner end of rock shaft 30 is journaled in a bearing 32 formed in one wall of the casing. The other end of shaft 30 extends through and is journaled in a bearing 33 formed in a plug 34 screwed into the opposite side wall of casing 2. A hollow screw threaded extension 35 of plug member 34 extends outwardly so as to house an annular gasket or packing member 36, which surrounds shaft 30. A cap member 37 screwed onto the extension 35 is adapted to force a gland 38 against the packing 36 so as to form a steam tight joint about the rock shaft 30. The outer end 39 of rock shaft 30 is of non-circular form and adapted to be attached to any suitable form of lever or link mechanism whereby the rock shaft may be operated from a distance.

A crank-arm 40 is either formed on or at-

tached to the rock shaft 30 within the chamber 12 and projects substantially radially from the shaft and away from the valve 16, whereby it is adapted to swing through an arc at the side of shaft 30 away from the valve. The free upper end 41 of crank arm 40 is pivotally connected by means of pin 42 within the forked end 43 of an upper link 44. The other forked end 45 of link 44 is pivotally connected by means of pin 46 with the upper end 47 of a lower link 48. The lower forked end 49 of link 48 is pivoted by means of pin 50 to the free end 51 of the valve operating lever 18.

A locking lug 52 is formed centrally on the upper or outer side of the upper link 44. A closure plug 53 is screwed into an opening in the top of casing 2. Plug 53 is formed with a cylindrical chamber 54 in which is movably mounted a piston 55 normally pressed down by a spring 56, which is compressed between piston 55 and the cap member 57, which is screwed on to the plug 53 and closes the upper end of chamber 54. A pin or stud 58 having a rounded lower end projects downwardly from piston 55 into the path of movement of the locking cam or lug 52 on the upper link 44.

When the valve is closed, the parts will be substantially in the positions shown in Fig. 2. The lever 18 is lowered to such a position that the loosely pivoted valve plate 16 is entirely free to seat itself properly on valve seat 15, and the valve is held closed by the steam pressure within the chamber 12. A small flow of steam is permitted to "bleed" through the notch 17. In order to open the valve, the rock shaft 30 is rotated continuously in a clockwise direction, as seen in Figs. 1 and 2. At the beginning of this movement the links 44 and 48 will be in alignment, with the link 44 out of contact with shaft 30 so that the lifting force will be applied to the upper end of link 44 through the crank arm 40. As the crank arm 40 swings through its arc above the shaft 30, there will only be a relatively small upward lifting component of this motion applied to the links 44 and 48, so that a very powerful leverage is available for breaking the valve from its seat. The arm 29 of lever 18 will immediately contact with the lug 28 and tilt the valve plate so as to break it loose from its seat at the side above the bleeding notch 17. Directly after this first, and most difficult part of the valve opening movement has been accomplished, the under side of link 44 will come into contact with the side of rock shaft 30, whereupon the upper link 44 and rock shaft 30 will turn as a unit so that the lifting force is applied directly to the upper end of the lower link 48 and the valve is rapidly swung upward to the open position shown in Fig. 1. Towards the end of this movement the cam 52 on link 44 will pass under the locking detent

58, which will move upwardly against the resistance of spring 56 and then snap down behind the cam 52 to hold the parts in the open position shown in Fig. 1. The valve may be closed by imparting a counter clockwise rotation to the rock shaft 30, the detent 58 yielding to permit the cam 52 to be forced thereunder, after which the parts will move of their own weight to the closed position shown in Fig. 2.

The parts of this valve are simple, accessible and readily assembled and disassembled. The valve operating mechanism is very compact and requires only a small valve housing to contain the same and permit the necessary movements of the operating parts. This arrangement permits the operating rock shaft 30 to be placed closely adjacent the valve, and at the same time the necessary leverages are provided for breaking loose the valve and moving it to open or closed position without unusual effort.

I claim:

1. An end train pipe valve comprising a casing having inlet and outlet ports and a chamber therebetween, a valve seat mounted in the casing around the outlet port, a valve movable within the chamber toward or from the seat, there being a lug on the back of the valve, a lever pivoted at one end in the casing and extending transversely behind the valve, means loosely pivoting the lug to an intermediate portion of the lever, and means mounted within the casing and attached to the free end of the lever for swinging the lever into the chamber to lift the valve.

2. An end train pipe valve comprising a casing having inlet and outlet ports and a chamber therebetween, a valve seat mounted in the casing around the outlet port, a valve movable within the chamber toward or from the seat, there being a lug on the back of the valve, a lever pivoted at one end in the casing and extending transversely behind the valve, means loosely pivoting the lug to an intermediate portion of the lever, and means mounted within the casing and attached to the free end of the lever for swinging the lever into the chamber to lift the valve, the lug having an extension projecting over the lever whereby the initial movement of the lever will engage the extension to break the valve from its seat.

3. An end train pipe valve comprising a casing having inlet and outlet ports and a chamber therebetween, a valve seat mounted in the casing around the outlet port, a valve movable within the chamber toward or from the seat, there being a lug on the back of the valve, a lever pivoted at one end in the casing and extending transversely behind the valve, means loosely pivoting the lug to an intermediate portion of the lever, and means mounted within the casing and attached to the free end of the lever for swinging the

lever into the chamber to lift the valve, the lug having an extension projecting over the free arm of the lever whereby the initial movement of the lever will engage the extension to break the valve from its seat.

4. An end train pipe valve comprising a casing having inlet and outlet ports and a chamber therebetween, a valve seat mounted in the casing around the outlet port, a valve movable within the chamber toward or from the seat, there being a lug on the back of the valve, a lever pivoted at one end in the casing and extending transversely behind the valve, means loosely pivoting the lug to an intermediate portion of the lever, and means mounted within the casing and attached to the free end of the lever for swinging the lever into the chamber to lift the valve, the lug having an extension projecting over the lever whereby the initial movement of the lever will engage the extension to break the valve from its seat, there being a bleeding notch in the valve seat on the side thereof beneath the lug extension.

5. An end train pipe valve comprising a casing having inlet and outlet ports and a chamber therebetween, a valve seat mounted in the casing around the outlet port, a valve movable within the chamber toward or from the seat, there being a lug on the back of the valve, a lever pivoted at one end in the casing and extending transversely behind the valve, means loosely pivoting the lug to an intermediate portion of the lever, and means mounted within the casing and attached to the free end of the lever for swinging the lever into the chamber to lift the valve, the lug having an extension projecting over the free arm of the lever whereby the initial movement of the lever will engage the extension to break the valve from its seat, there being a bleeding notch in the valve seat on the side thereof beneath the lug extension.

6. An end train pipe valve comprising a casing having inlet and outlet ports and a chamber therebetween, a valve seat mounted in the casing around the outlet port, a valve movable within the chamber toward or from the seat, a lever pivoted at one end in the casing and extending transversely behind the valve, means loosely pivoting the valve to an intermediate portion of the lever, a rockshaft mounted in the casing, and connections between the shaft and the free end of the lever whereby the initial rocking movement of the shaft will exert a powerful leverage to break the valve from its seat and further movement of the shaft will rapidly swing the valve away from the seat.

7. An end train pipe valve comprising a casing having inlet and outlet ports and a chamber therebetween, a valve seat mounted in the casing around the outlet port, a valve movable within the chamber toward or from the seat, a lever pivoted at one end in the

- 5 casing and extending transversely behind the valve, means loosely pivoting the valve to an intermediate portion of the lever, a rockshaft mounted in the casing, and connections between the shaft and the free end of the lever whereby the initial rocking movement of the shaft will exert a powerful leverage to break the valve from its seat and further movement of the shaft will rapidly swing the valve away from the seat, and means mounted in the casing and yieldingly engageable with a portion of the connections to hold the valve in open position.
- 10 8. An end train pipe valve comprising a casing having inlet and outlet ports and a chamber therebetween, a valve seat mounted in the casing around the outlet port, a valve movable within the chamber toward or from the seat, a lever pivoted at one end in the casing and extending transversely behind the valve, means loosely pivoting the valve to an intermediate portion of the lever, a rockshaft mounted in the casing and connections between the rockshaft and the free end of the lever comprising a crank arm on the shaft, a link pivoted to the lever, and a link connecting the first link with the free end of the crank arm, the latter link being out of contact with the shaft when the valve is closed but engaging and rocking with the shaft after the opening movement of the valve has been started.
- 15 9. An end train pipe valve comprising a casing having inlet and outlet ports and a chamber therebetween, a valve seat mounted in the casing around the outlet port, a valve movable within the chamber toward or from the seat, a lever pivoted at one end in the casing and extending transversely behind the valve, means loosely pivoting the valve to an intermediate portion of the lever, a rockshaft mounted in the casing and connections between the rockshaft and the free end of the lever comprising a crank arm on the shaft, a link pivoted to the lever, and a link connecting the first link with the free end of the crank arm, the latter link being out of contact with the shaft when the valve is closed but engaging and rocking with the shaft after the opening movement of the valve has been started, and means mounted in the casing and yieldingly engageable with the last mentioned link to hold the valve in open position.
- 20 10. An end train pipe valve comprising a casing having inlet and outlet ports and a chamber therebetween, a valve seat mounted within the casing around the outlet port, a valve movable within the chamber, movable guide means in the chamber for carrying the valve into or out of engagement with the valve seat, a rockshaft mounted in the casing, a crank arm on the shaft, and a pair of links pivotally joined together and connecting the crank arm with the guide means, both links being free of the shaft when the valve is closed whereby the initial opening movement is applied through the crank arm and both links, the outer link subsequently moving into engagement with the shaft as the valve is opened and rocking therewith.
- 25 11. An end train pipe valve comprising a casing having inlet and outlet ports and a chamber therebetween, a valve seat mounted within the casing around the outlet port, a valve movable within the chamber, movable guide means in the chamber for carrying the valve into or out of engagement with the valve seat, a rockshaft mounted in the casing, a crank arm extending substantially radially from the shaft and adapted to swing through an arc on the side of the shaft remote from the valve, a pair of links, one end of one link being pivotally connected with one end of the other link, the other end of one link being pivotally connected with the free end of the crank arm, and the other end of the second link being pivotally attached to the guiding means, the first mentioned link being adapted to swing into engagement with the rockshaft and rock therewith after the initial rocking movement of the shaft has broken the valve from its seat.
- 30 12. An end train pipe valve comprising a casing having inlet and outlet ports and a chamber therebetween, a valve seat mounted in the casing around the outlet port, a valve movable within the chamber toward or from the seat, a lever pivoted at one end in the casing and extending transversely of the valve and intermediately pivoted loosely to the valve, a rockshaft pivoted within the casing, a crank arm extending radially from the shaft and adapted to swing through an arc on the side of the shaft remote from the valve, a pair of links, one end of one link being pivotally connected to one end of the other link, the other end of one link being pivoted to the free end of the crank arm, and the other end of the second link being pivotally attached to the free end of the lever, the first mentioned link being adapted to swing into engagement with the rockshaft after the initial rocking movement of the shaft has broken the valve from its seat.
- 35 13. An end train pipe valve comprising a casing having inlet and outlet ports and a chamber therebetween, a valve seat mounted in the casing around the outlet port, a valve movable within the chamber toward or from the seat, a lever pivoted at one end in the casing and extending transversely of the valve and intermediately pivoted loosely to the valve, a rockshaft pivoted within the casing, a crank arm extending radially from the shaft and adapted to swing through an arc on the side of the shaft remote from the valve, a pair of links, one end of one link being pivotally connected to one end of the other link, the other end of one link being 100
- 40 100
- 45 110
- 50 115
- 55 120
- 60 125
- 65 130

pivoted to the free end of the crank arm, and the other end of the second link being pivotally attached to the free end of the lever, the first mentioned link being adapted to move as a unit with the rockshaft and crankarm after the initial rocking movement of the shaft has broken the valve from its seat.

14. An end train pipe valve comprising a casing having inlet and outlet ports and a chamber therebetween, a valve seat mounted in the casing around the outlet port, a valve movable within the chamber toward or from the seat, a lever pivoted at one end in the casing and extending transversely of the valve and intermediately pivoted loosely to the valve, a lug on the valve in position to be engaged by a portion of the lever whereby the initial movement of the lever will tilt the valve to break it from its seat, a rockshaft pivoted within the casing, a crank arm extending radially from the shaft and adapted to swing through an arc on the side of the shaft remote from the valve, a pair of links one end of one link being pivotally connected to one end of the other link, the other end of one link being pivoted to the free end of the crank arm, and the other end of the second link being pivotally attached to the free end of the lever, the first mentioned link being adapted to swing into engagement with the rockshaft after the initial rocking movement of the shaft has broken the valve from its seat.

15. An end train pipe valve comprising a casing having inlet and outlet ports and a chamber therebetween, a valve seat mounted in the casing around the outlet port, a valve movable within the chamber toward or from the seat, a lever pivoted at one end in the casing and extending transversely of the valve and intermediately pivoted loosely to the valve, a lug on the valve in position to be engaged by a portion of the lever whereby the initial movement of the lever will tilt the valve to break it from its seat, a rockshaft pivoted within the casing, a crank arm extending radially from the shaft and adapted to swing through an arc on the side of the shaft remote from the valve, a pair of links, one end of one link being pivotally connected to one end of the other link, the other end of one link being pivoted to the free end of the crank arm, and the other end of the second link being pivotally attached to the free end of the lever, the first mentioned link being adapted to move as a unit with the rockshaft and crank arm after the initial rocking movement of the shaft has broken the valve from its seat.

16. An end train pipe valve comprising a casing having inlet and outlet ports and a chamber therebetween, a valve seat mounted in the casing around the outlet port, a valve movable within the chamber toward or from

the seat, a lever pivoted at one end in the casing and extending transversely of the valve and intermediately pivoted loosely to the valve, a rockshaft pivoted within the casing, a crank arm extending radially from the shaft and adapted to swing through an arc on the side of the shaft remote from the valve, a pair of links, one end of one link being pivotally connected to one end of the other link, the other end of one link being pivoted to the free end of the crank arm, and the other end of the second link being pivotally attached to the free end of the lever, the first mentioned link being adapted to move as a unit with the rockshaft and crankarm after the initial rocking movement of the shaft has broken the valve from its seat, there being a locking cam formed on the first mentioned link, and a yieldable locking detent mounted in the casing and adapted to detachably engage the cam to hold the valve in open position.

17. An end train pipe valve comprising a casing having inlet and outlet ports and a chamber therebetween, a valve seat mounted in the casing around the outlet port, a valve movable within the chamber toward or from the seat, a lever pivoted at one end in the casing and extending transversely of the valve and intermediately pivoted loosely to the valve, a lug on the valve in position to be engaged by a portion of the lever whereby the initial movement of the lever will tilt the valve to break it from its seat, a rockshaft pivoted within the casing, a crank arm extending radially from the shaft and adapted to swing through an arc on the side of the shaft remote from the valve, a pair of links, one end of one link being pivotally connected to one end of the other link, the other end of one link being pivoted to the free end of the crank arm, and the other end of the second link being pivotally attached to the free end of the lever, the first mentioned link being adapted to move as a unit with the rockshaft and crank arm after the initial rocking movement of the shaft has broken the valve from its seat, there being a locking cam formed on the first mentioned link and a yieldable locking detent mounted in the casing and adapted to detachably engage the cam to hold the valve in open position.

EDWARD A. RUSSELL.