

Sept. 10, 1929.

J. J. McBRIDE

1,727,660

PLACARD AND HOLDER THEREFOR

Filed Sept. 30, 1927

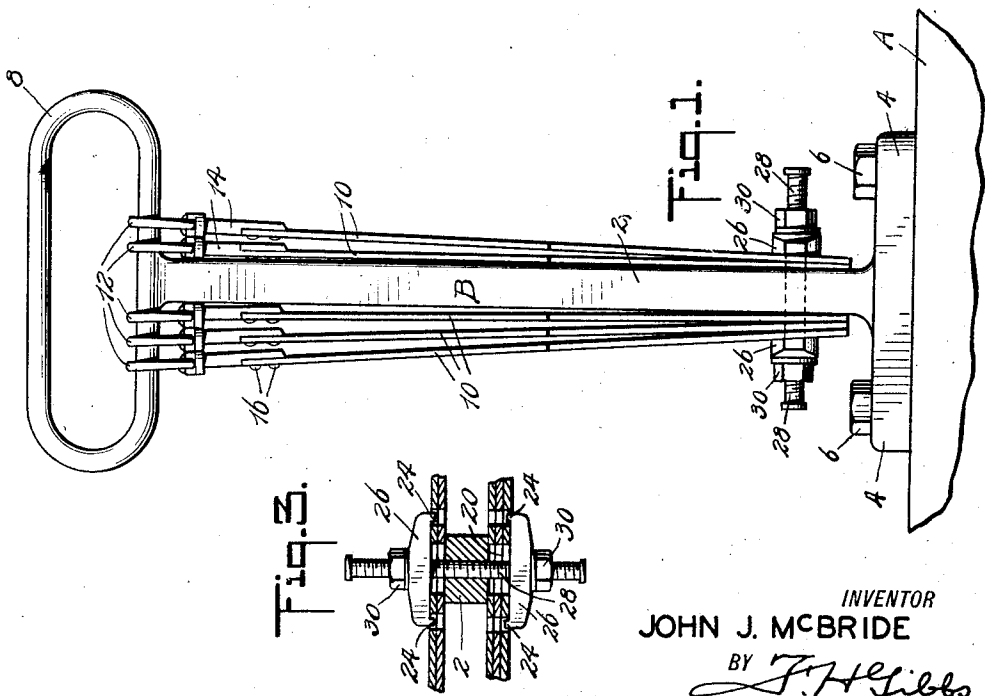
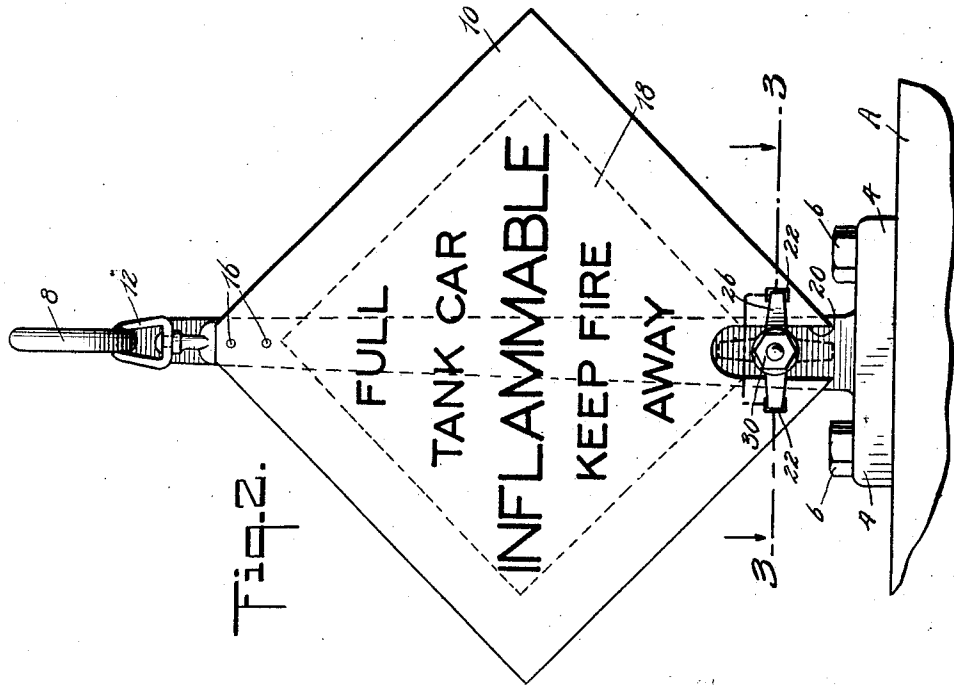

INVENTOR
JOHN J. McBRIDE
BY *J. H. Libbs*
ATTORNEY

UNITED STATES PATENT OFFICE.

JOHN J. McBRIDE, OF BAYONNE, NEW JERSEY, ASSIGNOR TO AMERICAN CAR AND
FOUNDRY COMPANY, OF NEW YORK, N. Y., A CORPORATION OF NEW JERSEY.

PLACARD AND HOLDER THEREFOR.

Application filed September 30, 1927. Serial No. 223,029.

This invention relates to placard holders, and will be best understood from the following description, reference being had to the accompanying drawings which illustrate the preferred form of the invention; though it is to be understood that the invention is not limited to the exact details of construction shown and described, as it is obvious that various modifications thereof within the scope of the claims will occur to persons skilled in the art.

In said drawings:

Figure 1 is a side elevation of the device;

Figure 2 is a front elevation of the device;

15 and

Fig. 3 is a sectional view on the line 3—3 of Fig. 2.

This invention relates to placard holders particularly adapted for use with tank cars employed for transporting inflammable fluid such as gasoline or the like.

One object of the invention is the provision of a holder of strong and durable construction which supports a plurality of placards each having a warning on both faces thereof, said placards being supported in such a manner that any desired warning may be exposed to view.

Another object of the invention is the provision of a placard board holder to take care of a multiplicity of placards such as are generally employed with tank cars or the like.

A further object of the invention is the provision of a placard board holder for retaining and supporting a multiplicity of placard boards each having a plurality of warnings, the boards being held in such a manner that they may be reversed to expose a warning on either side, as desired.

Other objects and advantages of this invention will be apparent from the following description taken with the accompanying drawings, in which A indicates a portion of a car to which is applied the placard holder indicated generally at B. The holder B comprises a standard 2 having an attaching foot 4 by which it may be secured to the car by bolts 6 or the like. The standard includes an elongated loop 8 defining a placard board

carrier and from which the placard boards 10 depend.

The placard boards 10 are carried by swivels each including an eye 12 mounted for movement in the loop 8, the swivels each pivotally supporting an attaching plate 14 to which the placard boards 10 are secured as by rivets 16. As shown clearly in the drawings, the loop 8 is arranged in a vertical plane so that the placard boards 10 may be swung from one side of the standard 2 to the opposite side as will be obvious. The placard boards 10 may be formed of any suitable or desired material, but it has been found satisfactory to provide boards of metal to obtain a permanent structure and to attach to the boards the sights 18 of paper or the like having suitable warnings printed thereon. In practice a sight is attached to both sides of the board 10 thereby acquiring a multiplicity of warnings, though it is obvious that the sides of the boards 10 may be embossed with the requisite lettering or the lettering may be painted thereon.

As shown in Fig. 2, the attaching plate 14 engages or is secured to one corner of the board 10, the latter being shown as substantially a square board. The corner opposite the swivel is slotted as shown at 20 and the board is provided with oppositely arranged apertures 22 positioned on either side of the slot 20 and arranged to be engaged by the arms 24 of yokes 26 positioned on opposite sides of the standard and mounted on a rod 28 which extends through the standard and is threadedly secured therein. For clamping the yokes in engagement with the placard boards 10, suitable binding nuts 30 are provided.

In the normal position, the placard boards 10 are retained in the position illustrated in Fig. 2 by the top swivels 12 and the yokes 26. When it is desired to shift the placard boards to expose a particular warning, the nuts 30 are backed off until the yokes can be swung to the position shown in dotted lines in Fig. 2. The slots being of sufficient size to receive the yokes, the placard boards 10 can be moved from one side of the standard to the other until the desired warning is ex-

posed, or any one or all of the boards may be turned on the swivels to expose a particular warning. When the desired warning is exposed, the yokes are then replaced and the placard boards again secured thereby.

What is claimed is:

1. A device of the kind described comprising a standard for attachment to a support, supporting means at the upper end of the standard, swivels mounted for movement on the supporting means, placards secured to said swivels, and means for securing the placards to the standard.
2. A device of the kind described comprising a standard for attachment to a support, a loop at the upper end of the standard, placard boards, swivels secured to the placard boards and mounted for movement in said loop, and means for releasably securing the placard boards to the standard.
3. A device of the kind described comprising a standard, a placard board carrier forming a part thereof, placard boards pivotally connected thereto to be swung from one side of the standard to the other and reversed while on either side of the standard, and releasable adjustable means connected to the standard adjacent the lower end thereof for securing the lower ends of the placard boards to each side of the standard.
4. A device of the kind described comprising a standard having a loop at its upper end, a plurality of placard boards, swivels mounted for movement in said loop and secured to the placard boards, each of said placard boards having a slotted lower end, and oppositely disposed yokes secured to the lower end of the standard and normally engaging the placard boards to retain the same, said yokes being movable to a position parallel with the slots in said placard boards to permit the latter to be moved on the loop from one side of the standard to the other or reversed as desired.
5. A device of the kind described comprising a standard having a vertically arranged loop at its upper end, a plurality of placard boards, swivels mounted for movement in said loop and secured to the placard boards, each of said placard boards having a slotted lower end, a rod extending through the standard at the lower end thereof, and oppositely disposed yokes secured to the rod and normally engaging the placard boards to retain the same, said yokes being movable on said rod to a position parallel with the slots in the placard boards to permit the latter to be moved on the loop from one side of the standard to the other or reversed as desired.
6. A device of the kind described comprising a T-shaped standard, pivotal means secured to the head of said standard and shiftable thereon, placard boards fixed to the said pivotal means and movable from one side of the standard to the other on shifting of the

pivotal means, and clamps arranged on each side of the standard for securing the placard boards thereto.

7. A device of the kind described comprising a standard, a placard board carrier forming a part thereof, placard boards reversible while on either side of the standard, pivotal means for supporting the placard boards, said pivotal means being shiftable on the carrier from one side of the standard to the other, and means releasably securing the placard boards to the standard.

In witness whereof I have hereunto set my hand.

JOHN J. McBRIDE. 80

85

90

95

100

105

110

115

120

125

130