

May 18, 1943.

V. WILLOUGHBY

2,319,759

OUTLET STRUCTURE FOR TANKS

Filed Aug. 19, 1941

2 Sheets-Sheet 1

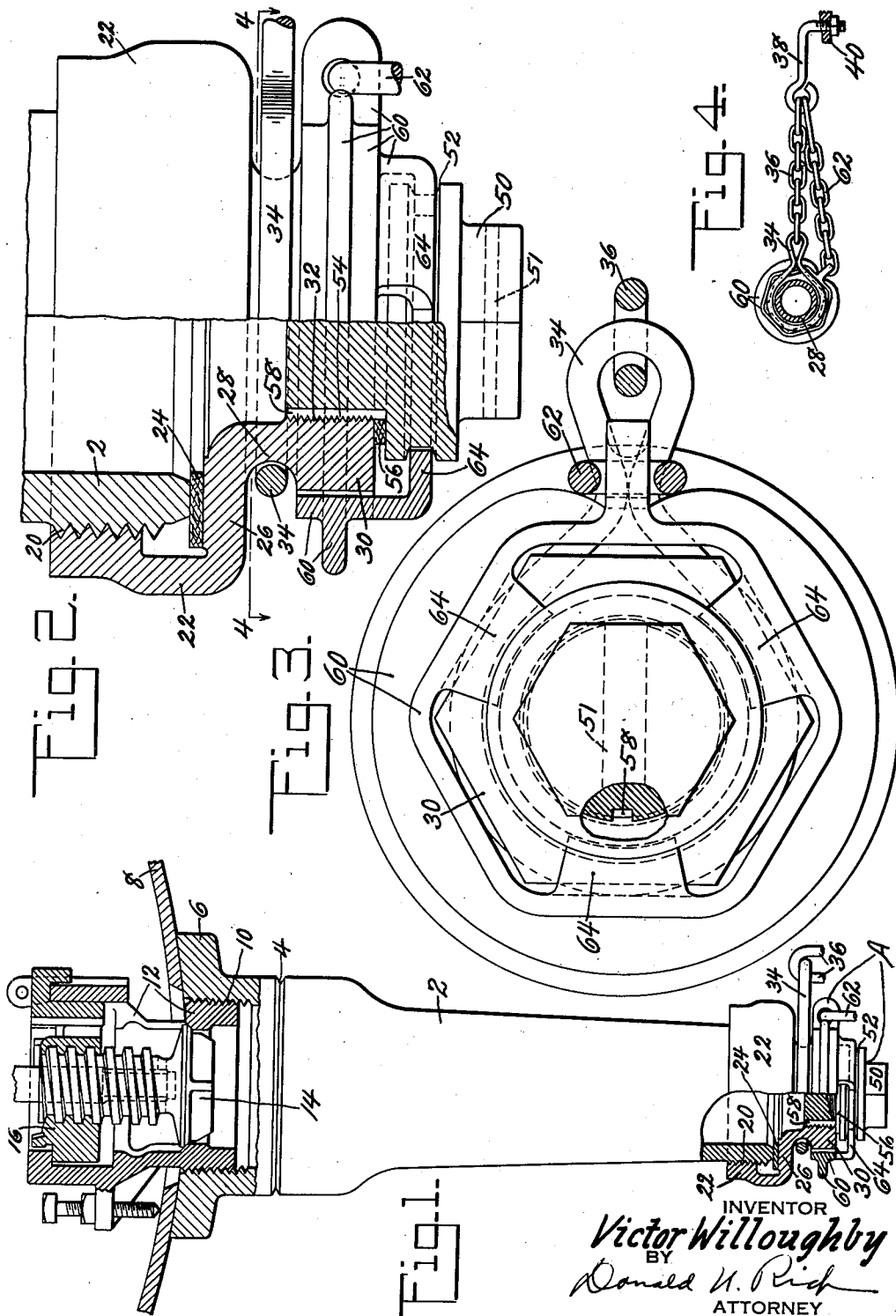

INVENTOR
Victor Willoughby
BY
Donald U. Rich
ATTORNEY

May 18, 1943.

V. WILLOUGHBY

2,319,759

OUTLET STRUCTURE FOR TANKS

Filed Aug. 19, 1941

2 Sheets-Sheet 2

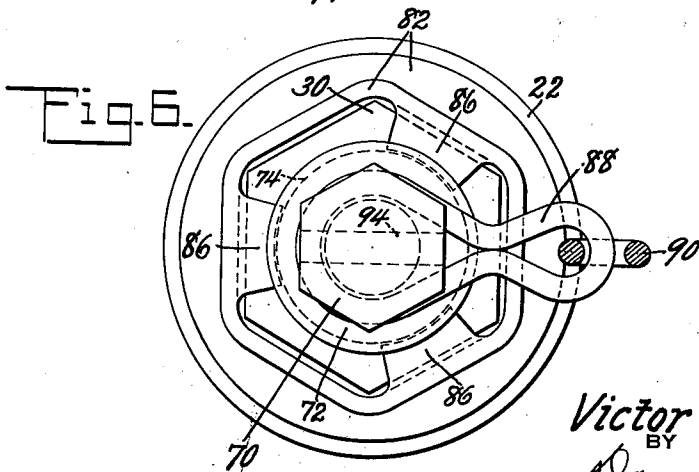
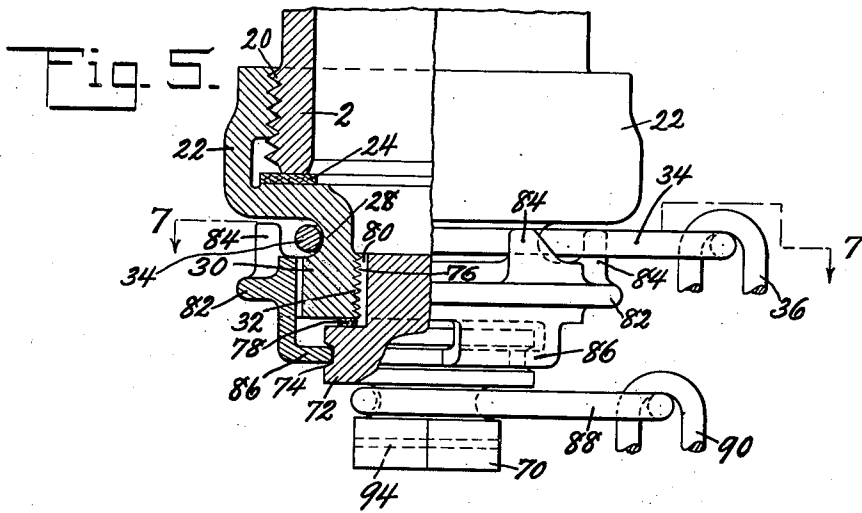
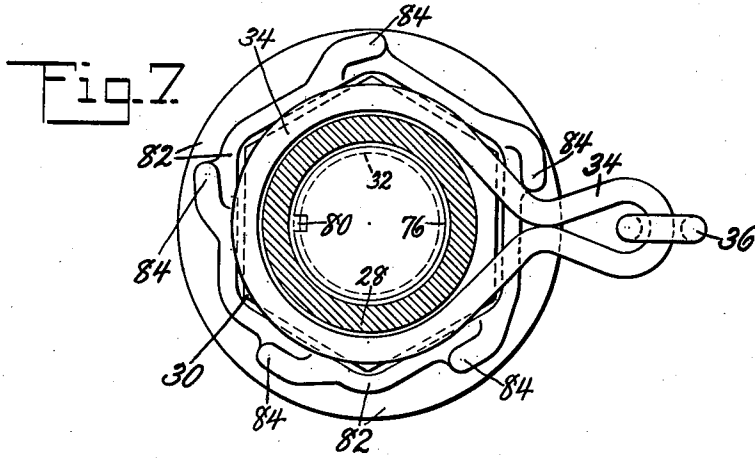

INVENTOR
Victor Willoughby
BY
Donald U. Rich
ATTORNEY

UNITED STATES PATENT OFFICE

2,319,759

OUTLET STRUCTURE FOR TANKS

Victor Willoughby, Ridgewood, N. J., assignor to
American Car and Foundry Company, New
York, N. Y., a corporation of New Jersey

Application August 19, 1941, Serial No. 407,499

13 Claims. (Cl. 220—39)

This invention relates to outlet structures for tanks in general and in particular to the discharge outlet structure of railway car tanks.

With present discharge outlets on railway car tanks free loss of lading occurs through either faulty manipulation during loading or discharge or due to vibration loosening parts during transit. Quite frequently when the tank is being loaded the outlet caps will be in place and the person filling the tank will neglect to close the tank valve. Under such conditions, unless a perfect seal is maintained, lading will be lost and, as sometimes happens, the entire tank may be emptied if the cap should loosen due to vibration during transit. Also with certain types of outlet valves theft of the lading has been possible by removing the cap and turning or lifting the valve by means of a special tool or rod. In some instances an inexperienced person attempting to unload the tank would first open the outlet valve and then remove the cap and attempt to make the outlet connections in a floor of lading escaping from the tank. Again, considerable loss of lading has been experienced due to a partially closed or defective outlet valve leading the person unloading the tank to the belief that the valve was closed and the error would not be discovered until the cap was removed and loss of lading had occurred. It is an object, therefore, of the present invention to provide an improved outlet structure which will positively permit a definite rate of flow for any material trapped in the outlet as soon as the cap has been loosened slightly.

Another object of the invention is the provision of an improved outlet structure having caps closing the outlet and which caps cannot be removed accidentally or by unauthorized persons.

A still further object of the invention is the provision of an improved outlet structure with a minor part thereof so designed as to be readily interchangeable with a part of existing structures to provide a structure which cannot be removed by unauthorized persons.

These and other objects of the invention will be apparent to persons skilled in the art from a study of the following description and accompanying drawings in which

Figure 1 is an elevational view of an outlet structure with parts being shown in section to better disclose the construction;

Fig. 2 is an enlarged elevational view partly in section of the improved outlet cap arrangement;

Fig. 3 is an inverted plan view of the improved outlet cap;

Fig. 4 is a reduced sectional view taken on line 4—4 of Fig. 2 disclosing the manner of locking the parts against rotation;

Fig. 5 is a view similar to Fig. 2 but showing a modification;

Fig. 6 is an inverted plan view of the construction shown in Fig. 5, and

Fig. 7 is a sectional view taken substantially on line 7—7 of Fig. 5.

Referring now to the drawings in detail, it will be seen that the conventional outlet casting 2 is provided having breaking notch 4 and flange 6 by means of which the casting may be attached to the lower portion of tank shell 8. The outlet casting is internally threaded at its upper end as at 10 to receive external threads of outlet valve member 12. This outlet valve may be of any approved design but as indicated is of the positive self-locking type having a valve 14 raised and lowered with respect to its seat by threads operating in a collar 16. The lower end of the outlet casting is threaded as at 20 to receive internal threads of a cap 22. Leakage past the threads of the cap and outlet is prevented by means of a gasket 24 firmly clamped between the lower end of the outlet casting and a shoulder 26 of the cap member. The cap member, as clearly shown, is of more or less conventional form standard to all tank cars and has a reduced circular portion 28 terminating in a hexagonal lower portion 30 which is internally threaded as at 32, thereby producing a reduced diameter outlet for discharge of lading. To prevent loss of the cap 22 a ring 34 surrounds the cap at the reduced circular portion 28 and this ring has attached thereto a chain 36 fastened by an anchor bolt 38 to any convenient fixed structure such as center sill flange 40, a part of which is shown in Fig. 4. So far the description of the outlet structure applies equally well to all of the figures and accordingly the same reference numerals have been used. Also it will be recognized that the preceding description applies equally well to practically all railway tank structures now in use.

In order to prevent unauthorized or accidental removal of cap 22 the combined cap plug and locking structure A is provided. As shown in Figs. 1 to 3 inclusive the cap 22 is closed by means of a plug having a hexagonal wrench receiving portion 50 merging into a shoulder portion having an interrupting annular groove 52 formed therein. The projecting or plug portion is threaded

as at 54 to engage threads 32 of the cap 22. Any leakage of lading past the threads 32 and 54 is effectively prevented by means of a gasket 56 compressed between the lower end of cap 22 and the shoulder of the plug. In order to immediately give indication of the presence of lading within the outlet casting upon a loosening of the plug a small groove 58 is cut longitudinally in the plug thus allowing passage of lading out of the outlet casting as soon as the plug has been loosened. In order to prevent rotation of the cap a ring-like locking structure 60 is provided having a hexagonal interior adapted to engage over the hexagonal portion 30 of the cap and this ring-like member is held against turning by a chain 62 anchored at one end to the ring-like locking member and at the other end to anchor bolt 38 or to some fixed structure. The ring-like locking member is provided with a plurality of angular fingers 64 having their inner ends bent inwardly and engaged within annular groove 52 of the cap plug, thus the cap plug will become a part of the ring-like locking member while being rotatable within the locking member.

In the form shown in Figs. 5 to 7 the cap plug is provided with a hexagonal wrench receiving portion 70 joined by a circular portion of reduced area to a shoulder 72 having an interrupting annular groove 74 formed therein. The projecting plug portion is threaded at 76 to engage the threads 32 of the outlet cap. Leakage of lading past the threads 32 and 76 is prevented by means of a gasket 78 compressed between the cap and shoulder of the plug, while escape of lading will be permitted by groove 80 as soon as the plug has been loosened slightly. In this form of locking arrangement the ring-like locking member 82 is provided with the hexagonal interior portion adapted to engage over the hexagonal portion 30 of the cap and is locked against rotation by means of a plurality of upstanding fingers 84. These fingers 84 are adapted to engage the ring 34 which is anchored to the car or some rigid structure by a chain 36. As in the previous form, the ring-like locking member 82 is provided with a plurality of inturned fingers 86 adapted to engage the slot 74 formed in the cap plug. Loss of the combined cap plug and ring-like locking member is prevented by means of a ring 88 rotatably engaging the plug in the reduced circular portion and this ring is anchored to the car structure or to the chain 36 by means of a chain 90, one link of which is shown.

In assembling the parts on the outlet casting the cap 22 will be screwed into position in the customary manner, after which the combined cap plug and locking member will be placed beneath the cap and the plug threads engaged with the threads of the cap, then in the form shown by Figs. 1 to 4 the ring-like locking member 60 will be turned in a counterclockwise direction as viewed from the bottom as far as the chain 62 will permit while still allowing the hexagonal portions of the member to be in alignment with the hexagonal portions of the cap 22. Rotation of the cap plug in a clockwise direction to tighten the plug will cause the plug to be moved inwardly compressing gasket 56 and in its inward movement sliding the ring-like locking member upwardly over the hexagonal portion 30 of the cap 22. With the parts in this position everything is tight and leakage will be prevented and the plug may be sealed by means of a seal passing through a chain link and through the slot 51 formed in the cap plug. Any attempt to remove

cap 22 will, of course, result in a counterclockwise rotation of the cap as viewed from the bottom, but such a rotation is prevented since chain 62 is anchored to a rigid structure and to the ring-like locking member 60 non-rotatably engaged with the hexagonal portion of the cap.

In the form shown in Figs. 5 to 7 inclusive and assuming the cap 22 to be in position on the outlet casting, the combined plug and locking member will be raised into position with the hexagonal portion of locking ring 82 so located as to be capable of sliding upwardly onto the hexagonal portion 30 of the cap. The entire plug and ring-like locking member may be held in such position by a slight engagement of the plug threads with the threads of the cap. With the parts in position as indicated the ring 34 is rotated as far as possible in a counterclockwise direction as viewed from the bottom, after which the cap plug is rotated in a clockwise direction tightening the plug and sliding ring-like locking member 82 vertically upward into close engagement with the hexagonal portion of the cap and with the fingers 84 engaging the ring 34. The arrangement can then be sealed by means of a seal passing through a link of chain 90 and slot 94 formed in the plug head. In this form unauthorized removal of the cap is prevented since any attempt to rotate the cap in a counterclockwise direction as viewed from the bottom will cause a finger 84 to engage ring 34 and tend to carry this ring with it but such movement is prevented by chain 36 which has been made taut by the proper adjustment during assembly.

With both forms of the invention it will be seen that the combined plug and ring-like locking member or locking assembly is capable of application to the majority of existing structures since it may be merely substituted for the present simple form of pipe plug. It will also be apparent that although the cap 22 has been shown as directly applied to an outlet casting, the arrangement will be equally effective if the cap 22 is attached to a reducer which in turn is attached to the outlet casting, for any attempt to remove the reducer or cap would be prevented by the ring-like locking member. Also it will be apparent that with the improved plug having a leakage groove cut therein any trapped lading in the outlet casting may escape and immediately warn the person operating the plug that lading is present in the casting. If upon opening the plug slightly the leakage flow does not immediately or substantially stop, the operator will know that the main outlet valve is not closed or is faulty and the condition may be remedied before lading is lost in any substantial quantity.

Although the invention has been described more or less in detail with specific reference to two forms thereof, it will be apparent to persons skilled in the art that various modifications and rearrangements of parts, other than those shown and described, are possible and all such modifications and rearrangements of parts are contemplated as will fall within the scope of the appended claims defining my invention.

What is claimed is:

1. A tank outlet structure comprising, an outlet member, a cap secured to the lower end of the outlet member and having a small opening therein, a plug closing the small opening in the cap, a locking member slidable over a non-round portion of said cap and being held in position by said plug, and means preventing rotation of

said locking member whereby said cap is locked on said outlet member.

2. A tank outlet structure comprising, an outlet member, a cap secured to the lower end of the outlet member and having a small opening therein, a plug closing the small opening in the cap, a locking member slidable over a non-round portion of said cap and being held in position by said plug, and means preventing rotation of said locking member whereby said cap is locked on said outlet member, said means including a chain anchored to a supporting structure for the tank.

3. A tank outlet structure comprising, an outlet member, a cap secured to the lower end of the outlet member and having a small opening therein, a plug closing the small opening in the cap and carrying a ring-like locking member slidable over a non-round portion of said cap during engagement of the plug in the cap, and means preventing rotation of said locking member when in engagement with the non-round portion of the outlet member whereby said cap is locked on said outlet member.

4. A tank outlet structure comprising, an outlet member, a cap screwed onto the lower end of the outlet member and having a small opening therein, a plug screwed into and closing the small opening in the cap, a locking member slidable over a non-round portion of said cap and held in position by said plug, and means anchored to said locking member and to a fixed structure whereby said cap cannot be unscrewed from the outlet member.

5. A tank outlet structure comprising, an outlet member, a cap screwed onto the lower end of the outlet member and having a small opening therein, a plug screwed into and closing the small opening in the cap, a locking member rotatably carried by said plug and slidable over a non-round portion of said cap during screwing of the plug into cap closing position, and means anchoring said locking member against rotation whereby said cap cannot be unscrewed from the outlet member.

6. A tank outlet structure comprising, an outlet member, a cap screwed onto the lower end of the outlet member and having a small opening therein, flexible means rotatably carrying said cap and anchored to a fixed structure to prevent loss of the cap when unscrewed from the outlet member, a plug screwed into and closing the small opening in the cap, flexible means connected to said plug and to a fixed structure to prevent loss of the plug when unscrewed from the cap, and a locking member slidable over a non-round portion of said cap and held in position by said plug when screwed into the cap, one of said flexible means having an operative connection with the locking member whereby said locking member is held against rotation thereby locking said cap on the outlet member.

7. A tank outlet structure comprising, an outlet member, a cap screwed onto the lower end of the outlet member and having a small opening therein, flexible means rotatably carrying said cap and anchored to a fixed structure to prevent loss of the cap when unscrewed from the outlet member, a combined cap plug and locking assembly for closing said small opening and simultaneously engaging a non-round portion of said cap, flexible means connected to said combined cap plug and locking assembly and to a fixed structure to prevent loss of the assembly when the plug is unscrewed from the cap, said

last named flexible means also preventing rotation of said locking assembly when in engagement with the cap whereby said cap is locked on the outlet member.

8. A tank outlet structure comprising, an outlet member, a cap screwed onto the lower end of the outlet member and having a small opening therein, flexible means rotatably carrying said cap and anchored to a fixed structure to prevent loss of the cap when unscrewed from the outlet member, a plug screwed into and closing the small opening in the cap, flexible means connected to said plug and to a fixed structure to prevent loss of the plug when unscrewed from the cap, and a locking member slidable over a non-round portion of said cap and held in position by said plug when screwed into the cap, said locking member having projections formed thereon engaging said first named flexible means whereby said locking member and cap are held against rotation relative to the outlet member.

9. A tank outlet structure comprising, an outlet member, a cap screwed onto the lower end of the outlet member and having a small opening therein, flexible means rotatably carrying said cap and anchored to a fixed structure to prevent loss of the cap when unscrewed from the outlet member, a plug screwed into and closing the small opening in the cap, flexible means connected to said plug and to a fixed structure to prevent loss of the plug when unscrewed from the cap, and a locking member slidable over a non-round portion of said cap and held in position by said plug when screwed into the cap, said locking member being directly connected to said last named flexible means whereby rotation of the locking member and cap are prevented thereby locking the cap on the outlet member.

10. As an article of manufacture, a combined cap plug and locking assembly for outlet structures and comprising, a ring-like locking member having a non-round opening slidable over a non-round portion of an outlet cap, a cap plug rotatably carried by said locking member for closing an opening in the cap and for sliding the locking member over the non-round portion of the outlet cap, and means fastened to said ring-like locking member and adapted to be secured to a fixed structure to prevent rotation of the ring-like member.

11. As an article of manufacture, a combined cap plug and locking assembly for outlet structures and comprising, a ring-like locking member having a non-round opening slidable over a non-round portion of an outlet cap, a cap plug rotatably carried by said locking member for closing an opening in the cap and for sliding the locking member over the non-round portion of the outlet cap, and projections formed on said ring-like locking member and engageable with anchor means to thereby prevent rotation of said ring-like locking member.

12. A tank outlet structure comprising, an outlet member, a cap secured to the lower end of the outlet member and having an opening therein, said cap being provided with a non-round portion, a plug closing the opening in the cap and being formed with an annular groove, a locking member engageable over the non-round portion of said cap and provided with portions extending into and co-operating with said groove to support the locking member, and retaining means connected with said locking member and adapted to prevent rotation thereof whereby said

cap is retained in locked relation with the said outlet member.

13. A tank outlet arrangement comprising, an outlet member, a cap secured to the lower end of the outlet member and being provided with a non-round portion, an opening in said cap, a plug closing the opening in the cap, a locking member adapted to be positioned over the non-round por-

tion of the cap and engaging said plug, said plug being so constructed and arranged as to constitute a support for said locking member, and retaining means connected with said locking member and adapted to prevent rotation thereof whereby said cap is retained in locked relation with the outlet member.

VICTOR WILLOUGHBY.