

Dec. 15, 1953

O. A. KUHLER ET AL
SLEEPING CAR BED

2,662,584

Filed Jan. 14, 1948

4 Sheets-Sheet 1

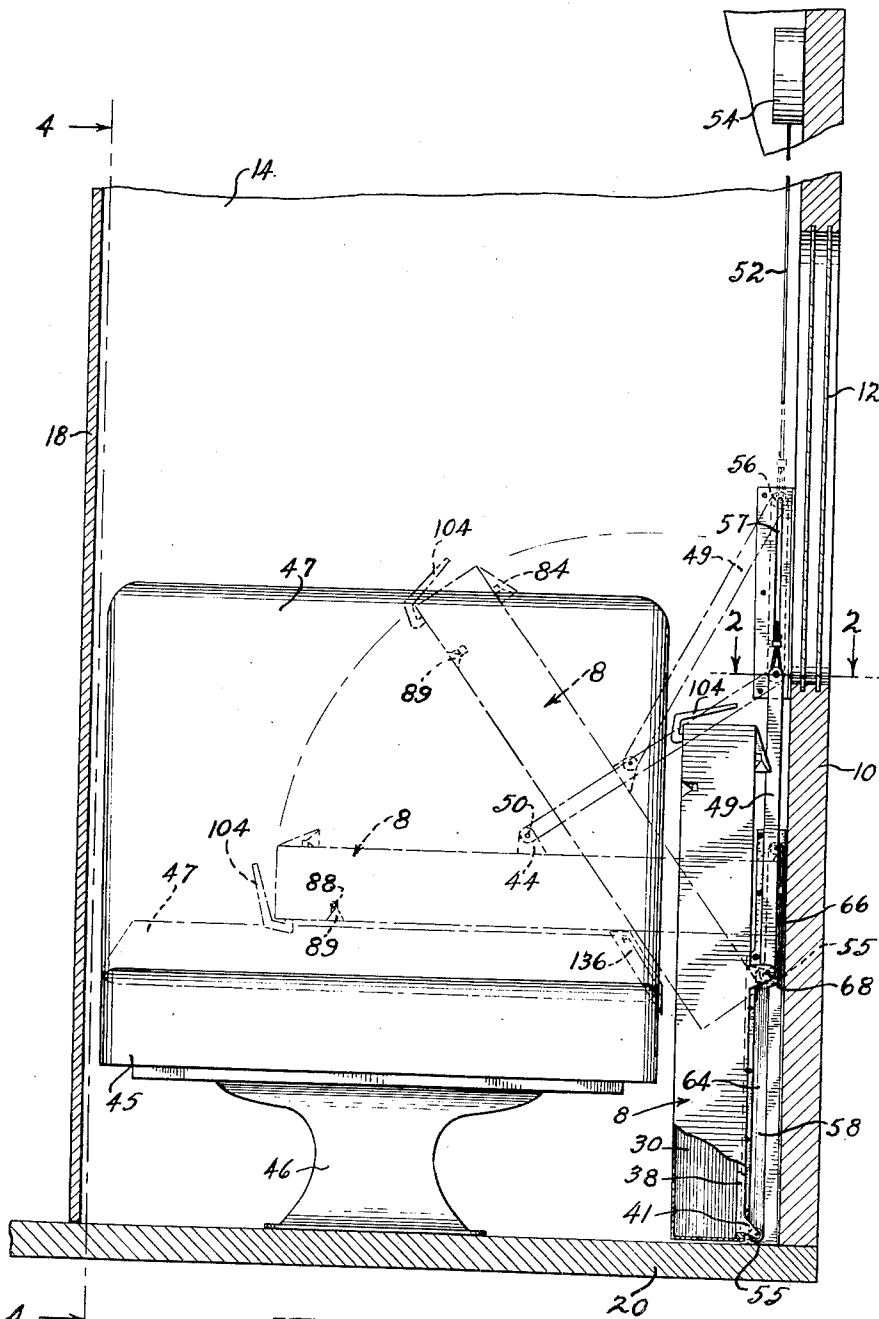

FIG. I

INVENTORS
Otto A. Kuhler &
William E. Burnett
BY George R. Ericson
ATTORNEY

Dec. 15, 1953

O. A. KUHLER ET AL

2,662,584

SLEEPING CAR BED

Filed Jan. 14, 1948

4 Sheets-Sheet 3

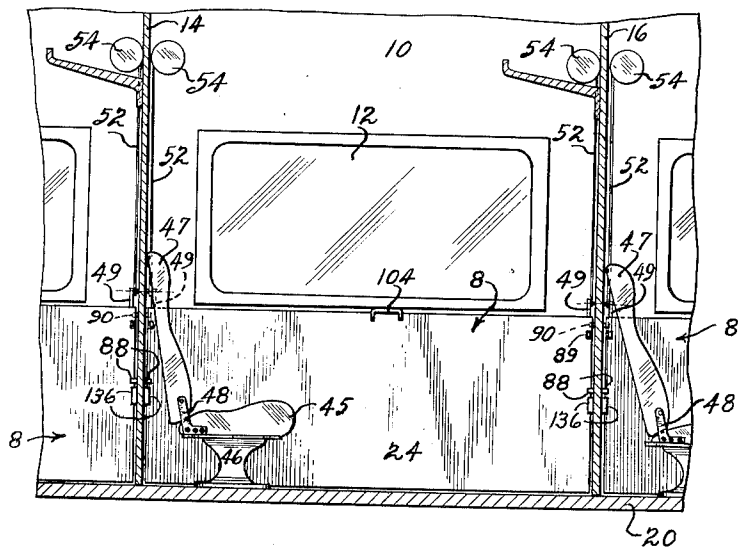

FIG. 4.

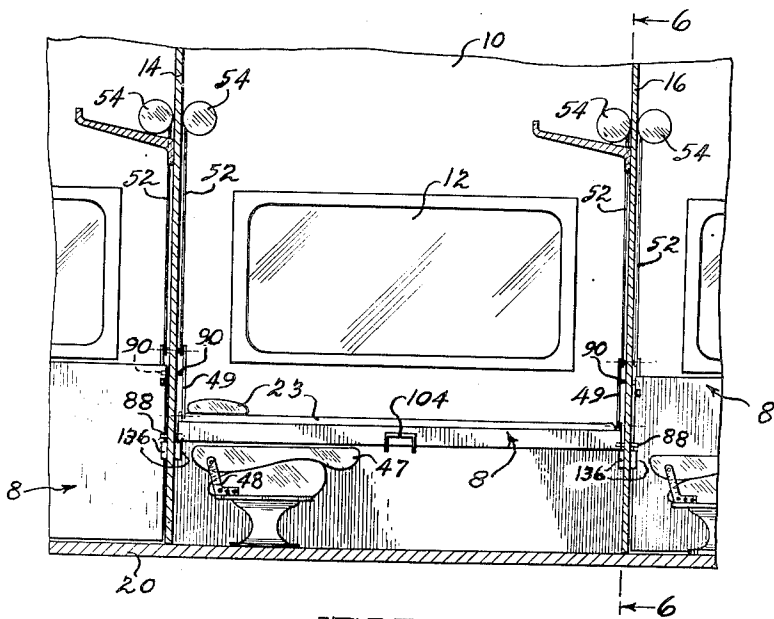

FIG. 5.

INVENTORS
Otto A. Kuhler &
William E. Burnett
BY George R. Ericson
ATTORNEY

Dec. 15, 1953

O. A. KUHLER ET AL

2,662,584

SLEEPING CAR BED

Filed Jan. 14, 1948

4 Sheets-Sheet 4

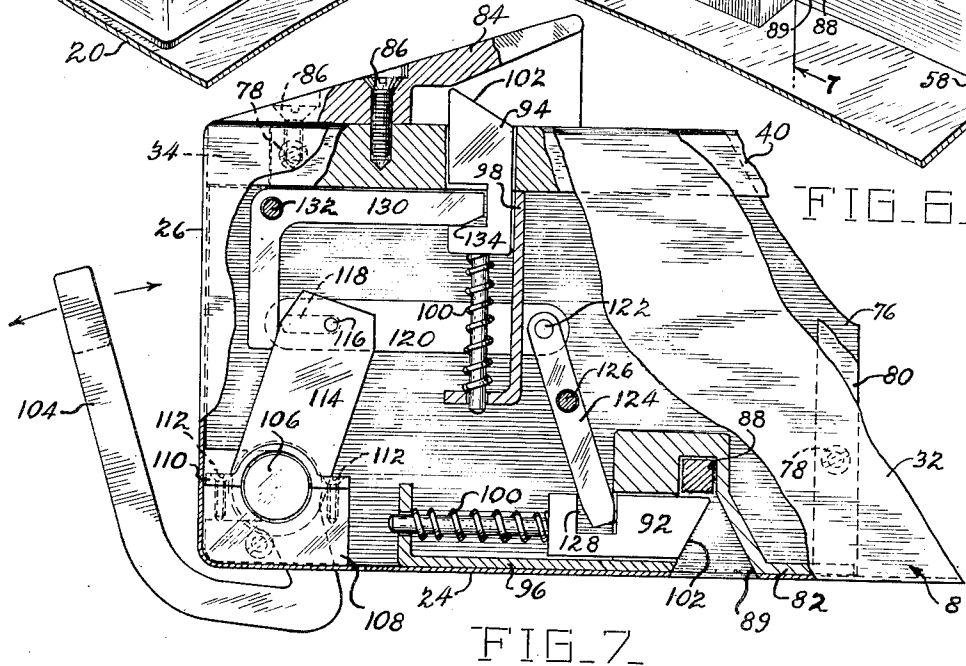
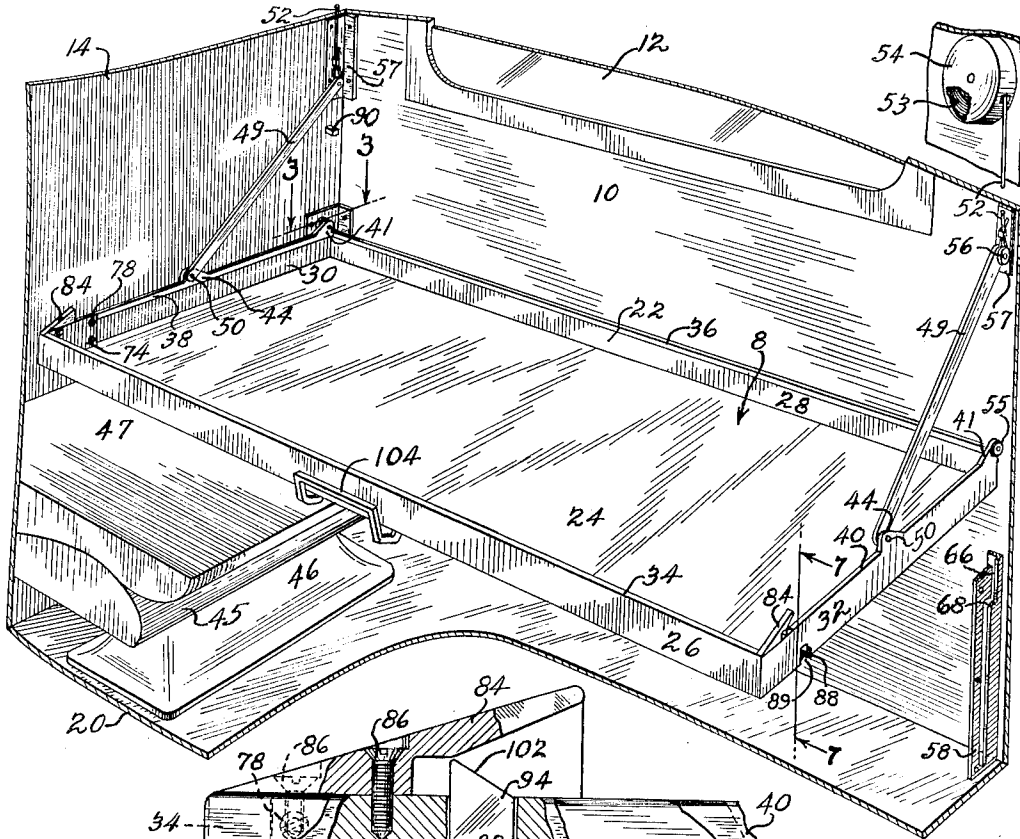

FIG. 6

FIG. 7

INVENTORS
Otto A. Kuhler &
William E. Burnett
BY George R. Ericson
ATTORNEY

UNITED STATES PATENT OFFICE

2,662,584

SLEEPING CAR BED

Otto A. Kuhler, Wheel Hill, Blauevelt, N. Y., and
William E. Burnett, Montclair, N. J., assignors
to American Car and Foundry Company, New
York, N. Y., a corporation of New Jersey

Application January 14, 1948, Serial No. 2,266

4 Claims. (Cl. 5—140)

1

This invention relates to beds and particularly to mounting and guide means for movable beds used in railway sleeping car rooms.

Due to space limitations in such rooms, particularly those of the single occupancy type, the seat, bed and lavatory facilities must be carefully designed and so arranged in the room as to provide the clearance necessary for their operation and use. Where a stationary seat extending transversely of the room is provided, a unitary rigid type bed is sometimes stored when not in use vertically on one side along the outer wall of the room. In order to provide maximum seat width in such an arrangement, the bed should be mounted so as to completely clear the seat during movement between its horizontal occupancy and stored positions. It is also desirable that the bed be so mounted as to eliminate the necessity of moving it all the way to fully stored position in order to make available sufficient occupant dressing space in the room or to permit access to the lavatory or toilet facilities.

One object of the present invention is to provide means for mounting and guiding a movable sleeping car bed so as to clear the side of a seat structure located closely adjacent the bed when the latter is in stored position whereby maximum seat width is obtained.

Another object of the invention is to provide an arrangement, as above described, wherein the bed will automatically be moved to an intermediate position when released from either stored or occupancy positions to provide standing room for the passenger to dress or to permit use of the lavatory facilities.

These and other objects of the invention will be apparent to those skilled in the art from a study of the following description and accompanying drawings, in which:

Fig. 1 is a partial transverse sectional view taken vertically through a railway sleeping car room showing the bed and seat installed therein, the bed being shown in vertical stored position by full lines and in intermediate and horizontal occupancy positions by broken lines;

Fig. 2 is a sectional view taken on line 2—2 of Fig. 1;

Fig. 3 is a sectional view on line 3—3 of Fig. 6;

Fig. 4 is a partial vertical sectional side view of adjoining railway sleeping car rooms taken on line 4—4 of Fig. 1 showing the bed in vertical stored position;

Fig. 5 is a view similar to Fig. 4, but showing the bed in horizontal occupancy position;

Fig. 6 is a fragmentary perspective view in the

2

sleeping car room with one end wall removed and showing the bed pan in horizontal position, and

Fig. 7 is a broken sectional detail view taken approximately on line 7—7 of Fig. 6 showing the latch mechanism for retaining the bed in either the stored or occupancy position.

Referring now more in detail to the drawings, the bed, generally indicated at 8, is shown as installed in a single occupancy sleeping car room defined by the car side wall 10 provided with a window 12, transverse end walls 14, 16, aisle wall 18 and floor 20.

The bed 8 comprises a rigid pan structure 22 provided with the necessary bedding 23. The bed pan, as more clearly shown in Fig. 6, comprises a rectangular bottom sheet 24 bounded by upstanding side wall members 26, 28 and end wall members 30, 32, suitably joined together to form the pan-shaped structure. The bed pan is reinforced by side and end stiffening bars 34, 36 and 38, 40, respectively, welded or otherwise secured to the inside upper edge portions of the pan side and end wall members. The end bars 38, 40 and end wall members 30, 32, adjacent their junction with side bar 36 and side wall member 28, are formed to provide upstanding or projecting ears 41 carrying short shafts 42. The end bars 38, 40 and end wall members 30, 32 are also formed centrally between their ends with similar upstanding ears 44.

A stationary seat structure is arranged at one end of the room and comprises a transversely extending seat 45, pedestal 46 and folding back 47. The seat is suitably mounted on the pedestal which is fixed to the floor and the seat back is hingedly connected to the pedestal by brackets 48 permitting it to be folded down on the seat.

The bed is stored when not in use in a vertical position with one side resting on the floor adjacent the outer wall 10 of the room and the seat extends transversely to a point closely adjacent the stored bed to thereby provide maximum seat width. The bed is mounted and guided by means now to be described whereby it will clear the closely adjacent end of the seat during its movement between stored and occupancy positions.

The bed is mounted by means including suspension links 49, one at each end of the bed, pivotally connected to the bed pan at one end by pins 50 extending through the ears 44. The other ends of links 49 carry short shafts 51 to which are attached cables 52 that extend upwardly where they are connected to torsion springs 53 housed in casings 54 secured to the outer room wall 10. Springs 53 are of sufficient strength to

over-balance the weight of the bed whereby the latter is automatically moved to intermediate position when released from either stored or occupancy position, as will hereinafter appear.

Movement of the bed is controlled by guide means which comprises rollers 55 journalled on the shafts 42 carried by the ears 41 on the bed pan, rollers 56 journalled on the shafts 51 at the ends of the links 49, and upper and lower vertical guideways 57, 58, respectively. The rollers 53 are arranged to ride in the upper vertical guideways 57, while the rollers 55 ride in the lower vertical guideways 58, the guideways being secured to outside wall 10 and transverse end walls 14, 16. Nuts 59 screwed on the outer ends of shafts 51 retain links 49 in position thereon. The guideways 57, 58, as more clearly shown in Figs. 2 and 3, respectively, are secured by screws 62 to the side wall 10 and to opposite sides of each end wall 14 of which they form a part.

As best shown in Figs. 1, 6, the lower portions 64 of lower vertical guideways 58 merge into parallel upper laterally offset portions 66 to provide bearings 68 against which the rollers 55 are engaged when the bed is in the intermediate or inclined position. The bed is automatically moved to this position upon its release from latch mechanism, as hereinafter described, by the springs 53 acting through cables 52, rollers 56 and suspension links 49, the rollers 56 being drawn upwardly against the tops of upper guideways 57.

During movement of the bed from vertical stored position, the rollers 55 on the bed pan ride upwardly in the lower portions 64 of lower guideways 58 until they reach the bearings 68. The bed will then tilt inwardly of the room by gravity to inclined intermediate position due to the offset connection of rollers 55 and links 49 with the bed pan by projecting ears 41 and 44, respectively, the rollers 55 being shifted into engagement with the guideway bearing portions 68. The bed is then manually moved to horizontal occupancy position where rollers 55 contact the tops of the upper offset portions 66 of lower guideways 58 and rollers 56 are forced downwardly against the tension of springs 53 to the bottom of upper guideways 57. When the bed is released from this position, the rollers 56 are again pulled upwardly to the tops of upper guideways 57 by springs 53, while the rollers 55 on the bed pan will ride downwardly in the upper offset portions 66 of lower guideways 58 until they come into engagement with bearings 68, moving the bed back to intermediate inclined position from where it is manually pushed down into vertical stored position against the force of springs 53. It will be seen that the suspension links 49 and rollers 56, 55 riding in upper and lower guideways 57, 58, respectively, control the swinging movement of the bed between a vertical stored position shown by full lines and a horizontal occupancy position shown by broken lines in Fig. 1. During movement of the bed from either of these positions, the rollers 55 will encounter and engage against the guideway bearing portions 68 to retain the bed in an intermediate inclined position also shown by broken lines in Fig. 1. Since the strength of springs 53 is sufficient to over-balance the total weight of the bed, the latter will always be urged toward and tend to assume its intermediate position.

The bed is retained either in vertical stored position or in horizontal position against the tension of springs 53 by latch mechanisms, one of which is shown in Fig. 7. A latch mechanism

is housed at each upper or inner corner of the bed pan in the space between the pan side wall 30 and a cover plate 74, and the pan side wall 32 and a similar cover plate 76 at the opposite end of the bed pan, as shown in Figs. 6, 7. The cover plates 74, 76 are positioned in place over the latch mechanisms by screws 78 securing them to the end stiffening bars 38, 40 and to spacer members 80. Since the latch mechanisms at opposite ends of the bed pan are identical, only one is shown and described in detail. The latch mechanism includes keepers 82 and 84, the latter being secured by screws 86 to the stiffening bars 38, 40 at opposite ends of the bed pan. The keepers 82 are adapted to engage pins or studs 88 through openings 89 in the pan end walls 30, 32 when the bed is moved to horizontal position. The keepers 84 of the latch mechanism are engageable with similar studs 90 when the bed is moved to its vertical stored position against the outside wall 10, the studs 88 and 90 projecting from opposite transverse walls 14, 16 at the proper locations. Spring pressed latching elements 92, 94, mounted in suitable supports 96, 98, respectively, serve to retain the keepers in engagement with their respective studs when the bed is in either the horizontal or the stored position.

The latching elements 92, 94 are constantly urged toward latching position by coiled springs 100 and are formed with an inclined edge 102 so as to be retracted upon engagement with the studs, permitting the latter to be received in and engaged by the keepers 82 or 84, as the case may be, depending on the position of the bed. The bed is moved from one position to the other and the latching elements 92, 94 are actuated by a single operating handle 104 fixed centrally on a shaft 106. The shaft is journalled in bearing members 108 carried by the bed pan and is retained in place by yokes 110 secured by screws 112 to the bearing members. An arm 114, fixed to each end of the shaft 106, carries a pin 116 arranged in slot 118 formed in a link 120 pivotally connected at 122 to one end of a lever 124. This lever is pivotally mounted at 126 in the latch mechanism housing with its other end operatively engaging a notch 128 in the latching elements 92. From the foregoing it will be seen that the latching elements 92 are actuated by movement of the operating handle 104 in a clockwise direction, or to the right, as viewed in Figure 7. The arm 114 is also in position to engage one end of a bell-crank 130 pivotally mounted at 132 in the latch mechanism housing and having its opposite end operatively engaging a similar notch 134 in latching element 94. Again referring to Figure 7, it is seen that due to the pin and slot or lost motion connection between arm 114 and link 120, the arm is free to swing upon movement of operating handle 104 in a counter-clockwise direction, or to the left, to actuate the latching elements 94. It will be understood that the latching elements 92 and keepers 82 are engageable with the studs 88 to retain the bed in horizontal occupancy position, while the latching elements 94 with their keepers 84 are engageable with the other studs 90 to retain the bed in the vertical stored position.

The combined weight of the bed and an occupant is to a great extent supported by the suspension links 49 with their rollers 53 engaged against the bottoms of upper guideways 57, and by the rollers 55 engaged against the tops of lower guideways 58. The occupant's weight on the bed will force rollers 56 down against the bottoms of upper guideways 57 and rollers 55 up against

5

the tops of lower guideways 52, thus firmly supporting the bed in horizontal position. While the principal purpose of the studs 22 is to retain the unoccupied bed in horizontal position, they also serve to additionally support the bed when occupied and provide a safety factor in event of failure of the suspension links 49. Also aiding in support of the bed when occupied and serving as a safety factor are guide cleats 136 secured to opposite transverse walls 14, 16 in supporting relationship to the bed. These guide cleats are secured to the walls in an inclined position whereby, as clearly shown in Figure 1, they also help to guide the bed assembly while being moved between its positions.

Operation of the bed is as follows, and assuming that the bed is in the vertical position stored on one side with the pan opening facing the car outside wall, as shown by full lines in Figure 1: the seat back 47 is first folded down against seat 45 to the position shown by broken lines in Figure 1. The handle 104 is then pulled, rotating the shaft 106 counter-clockwise and actuating latching elements 94 to release the keepers 84 from the studs 90. This will permit the bed to be lifted vertically upward by the force of springs 23 to a position where the rollers 55 encounter and engage against the bearing portions 68 of lower guideways 53 and rollers 56 reach the tops of upper guideways 57. Due to the offset connection of the links 48 and rollers 55 with the bed pan, as previously referred to, the bed will then swing or tilt inwardly of the room by gravity around the rollers 56 as a pivotal point to an intermediate inclined position, as shown by broken lines in Figure 1. The bed may then be moved to horizontal position by pushing down on handle 104, the bed swinging about the pivot pins 58 carried by ears 44 and the rollers 56 moving downwardly to the bottoms of upper guideways 57, while the rollers 55 move upwardly to the tops of lower guideways 53. The bed is then retained in horizontal position by engagement of the latching elements 92 and keepers 32 with the studs 22. By reference to Figure 1 it will be seen that the bed, during its movement from vertical stored position to horizontal position, has cleared the seat 45 with the back 47 folded down thereon. Should the passenger desire to use the lavatory facilities, or to dress, it is merely necessary to step out of the bed and push the handle 104, which will swing arms 114 in a clockwise direction, actuating levers 124 to retract latching elements 92 and release the bed. Due to the action of springs 53, the bed will swing upwardly around pins 53 and the rollers 55 will move downwardly in lower guideways 53 until they engage against or rest upon the bearing portions 68. The bed will then be in the midway or intermediate position, affording ample space in the room for the occupant to dress or use the lavatory facilities without the necessity of moving the bed all the way to stored position for this purpose. To return the bed to stored position, the handle 104 is pushed, to swing the bed about pins 53 and rollers 55 toward vertical position and to disengage the rollers from bearing portions 68 of guideways 53. The bed may now be pushed downwardly against the tension of springs 53 into fully stored position where it is retained by engagement of latching elements 94 and keepers 84 with studs 90.

While the invention has been described more or less in detail, it will be obvious that various modifications may be made by those skilled in

6

the art, and all such modifications are contemplated as will fall within the scope of the appended claims defining our invention.

What is claimed is:

1. In combination with a movable bed, means for mounting and guiding the bed for swinging movement about one side between a vertically extending stored position and a horizontally extending occupancy position comprising, suspension links pivotally connected at their lower ends to intermediate portions of the ends of the bed offset from the center of gravity of the bed when in stored position, lower vertical guideways having bearing portions intermediate the ends thereof, means adjacent the extremities of the said one side of the bed and projecting beyond the center of gravity thereof when in stored position arranged in said lower guideways, upper vertical guideways, means on the upper ends of said links arranged in the upper guideways, means for releasably securing the bed in either of said positions, and spring means acting to draw said means on the upper ends of said links upwardly into engagement against the tops of said upper guideways upon release of the bed from either of said positions causing said means projecting from the said one side of the bed to engage against said lower guideway bearing portions and said bed to be tilted about its guided side to and supported in an intermediate inclined position.

2. In combination with a movable bed having attachment portions projecting centrally beyond the tops of the ends and adjacent the extremities beyond the top of one side thereof, means for mounting and guiding the bed for swinging movement about the said one side between a vertically extending stored position and a horizontally extending occupancy position comprising, suspension links pivotally connected at their lower ends to said projecting portions of the ends of the bed, lower vertical guideways having a lower portion merging into an offset upper portion to provide bearing portions therebetween, means carried by said projecting portions on the said one side of the bed arranged in said lower guideways, upper vertical guideways, means on the upper ends of said links arranged in the upper guideways, means for releasably securing the bed in either of said positions, and spring means acting to draw said means on the upper ends of said links upwardly into engagement against the tops of said upper guideways upon release of the bed from either of said positions causing said means carried by the projecting portions on the said one side of the bed to engage against said lower guideway bearing portions and said bed to be tilted about its guided side to and supported in an intermediate inclined position.

3. In combination with a movable bed, means for mounting and guiding the bed comprising suspension links pivotally connected at one of their ends to portions projecting centrally beyond the tops of the ends of the bed, lower vertical guideways having a lower portion merging into an offset upper portion to provide bearing portions therebetween, rollers projecting beyond the top and adjacent to the extremities of one side of the bed arranged in said lower guideways, upper vertical guideways, rollers carried by the opposite ends of said suspension links arranged in the upper guideways whereby said bed may be swung about its guided side to a horizontal occupancy position, said bed being supported in occupancy position by engagement of the link carried rollers against the bottoms of said upper guideways and engagement of the rollers adjacent to the ex-

7

tremities of the guided side of the bed against the tops of said lower guideways, means for releasably securing the bed in said horizontal occupancy position, and spring means acting to draw said link carried rollers upwardly into engagement against the tops of said upper guideways when the bed is released from said horizontal position causing said rollers adjacent to the extremities of the said one side of the bed to engage against said lower guideway bearing portions and said bed to be tilted about its guided side to and supported in an intermediate inclined position

4. In combination with a movable bed, means for mounting and guiding the bed comprising suspension links pivotally connected at one of their ends to intermediate portions of the ends of the bed offset from the center of gravity thereof when in stored position, lower vertical guideways having a lower portion merging into an offset upper portion to provide bearing portions therebetween, rollers on the bed adjacent the extremities of one side and projecting beyond the center of gravity thereof when in stored position arranged in said lower guideways, upper vertical guideways, rollers carried by the opposite ends of said suspension links arranged in the upper guideways whereby said bed may

8

be swung about its guided side to a vertical stored position, means for releasably securing the bed in said vertical stored position, and spring means acting to draw said link carried rollers upwardly into engagement against the tops of said upper guideways when the bed is released from said stored position causing said rollers adjacent to the extremities of the said one side of the bed to engage against said lower guideway bearing portions and said bed to be tilted by gravity about its guided side to and supported in an intermediate inclined position.

OTTO A. KUHLER.
WILLIAM E. BURNETT.

References Cited in the file of this patent

UNITED STATES PATENTS

Number	Name	Date
1,812,853	Barnes -----	July 7, 1931
1,820,672	Muchlinski -----	Aug. 25, 1931
1,838,561	Matheson -----	Dec. 29, 1931
1,876,327	Lauterstein -----	Sept. 6, 1932
2,440,515	Kelly et al. -----	Apr. 27, 1948

FOREIGN PATENTS

Number	Country	Date
2,258	Great Britain -----	Feb. 4, 1905