

Sept. 27, 1938.

J. B. D. THOMPSON ET AL

2,131,493

RAILWAY CAR CONSTRUCTION

Filed April 12, 1935

4 Sheets-Sheet 1

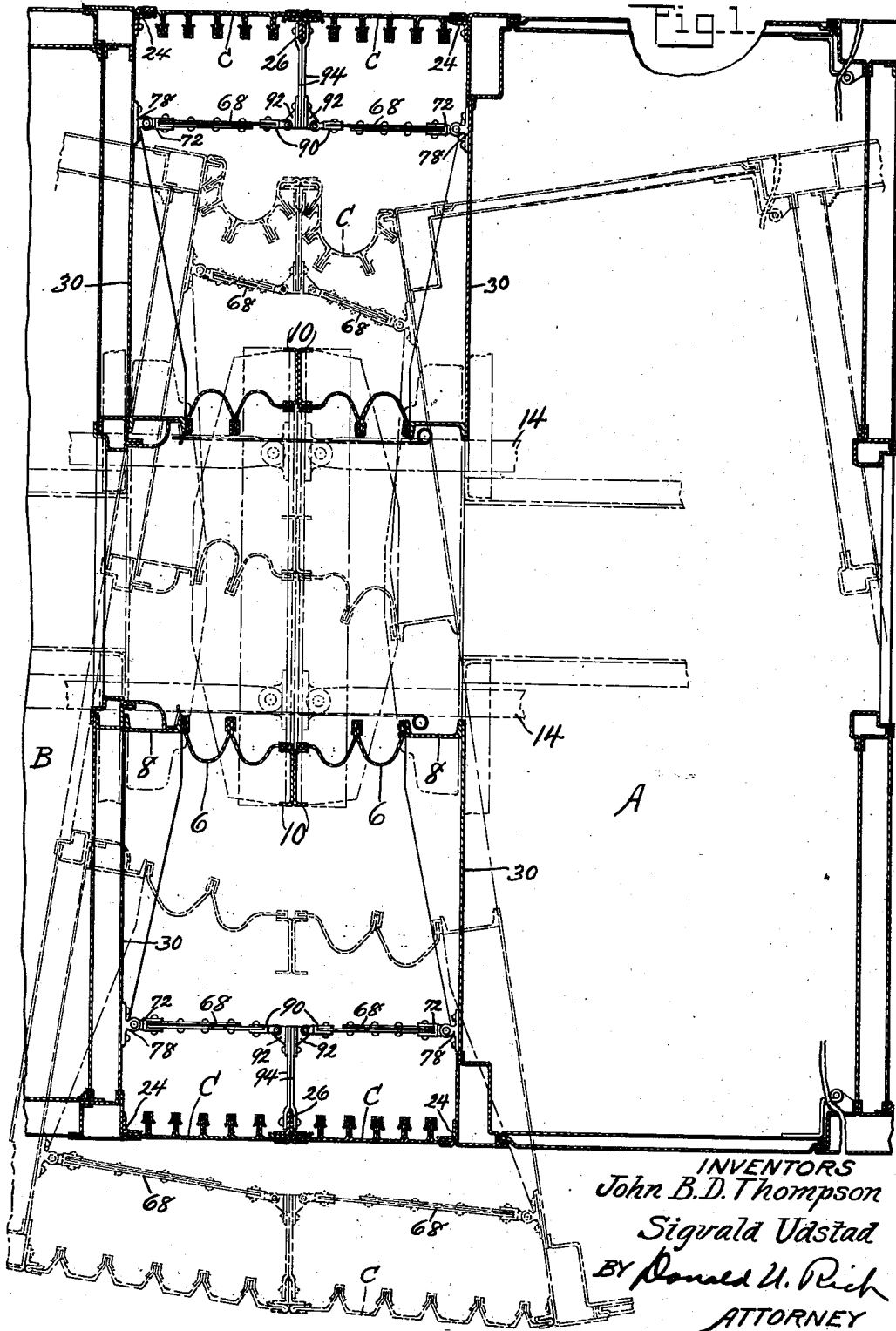

Sept. 27, 1938.

J. B. D. THOMPSON ET AL

2,131,493

RAILWAY CAR CONSTRUCTION

Filed April 12, 1935

4 Sheets-Sheet 2

Fig. 2.

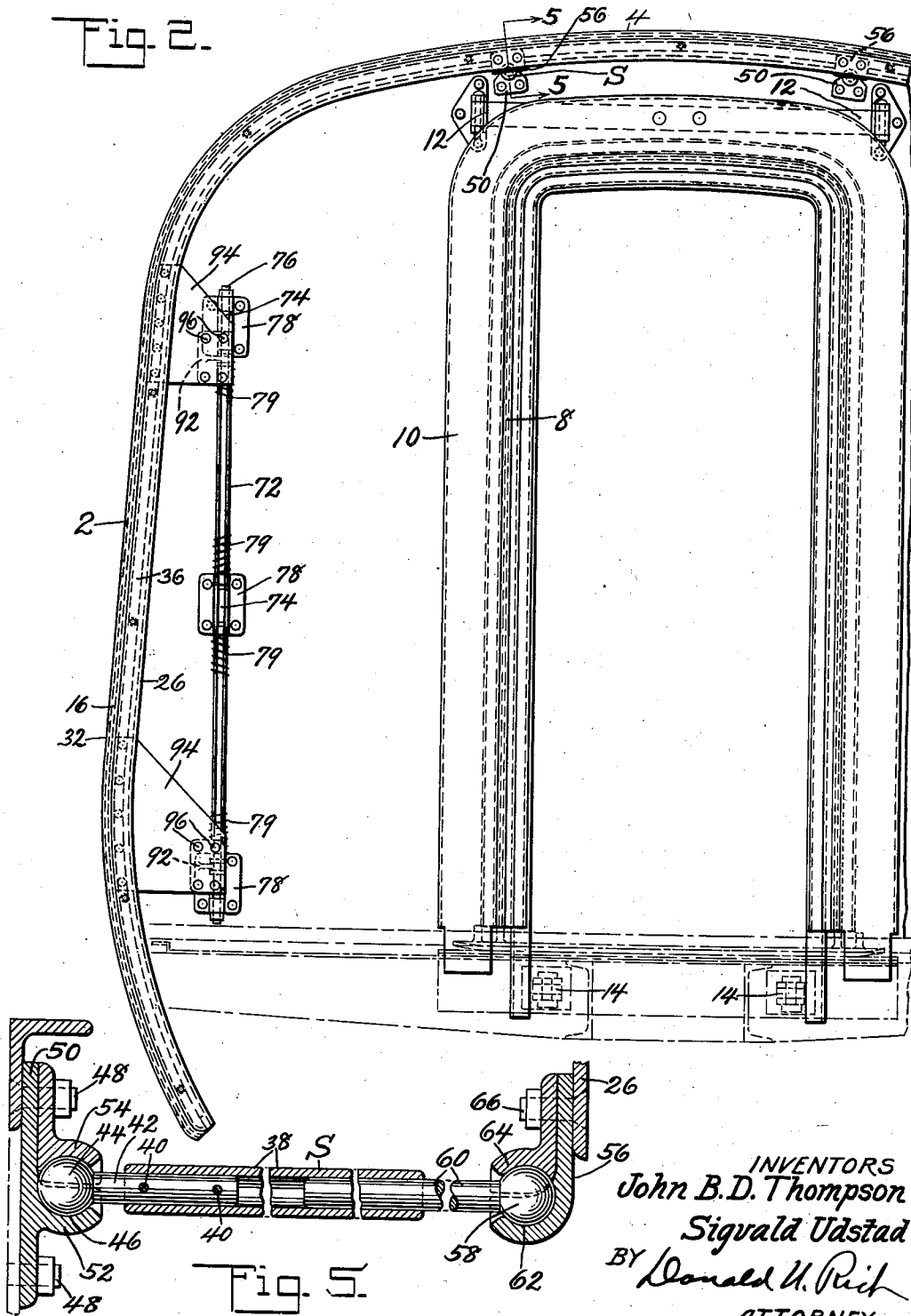

INVENTORS
John B. D. Thompson
Sigvald Udstad
BY Donald U. Rich
ATTORNEY

Sept. 27, 1938.

J. B. D. THOMPSON ET AL

2,131,493

RAILWAY CAR CONSTRUCTION

Filed April 12, 1935

4 Sheets-Sheet 3

Fig. 3.

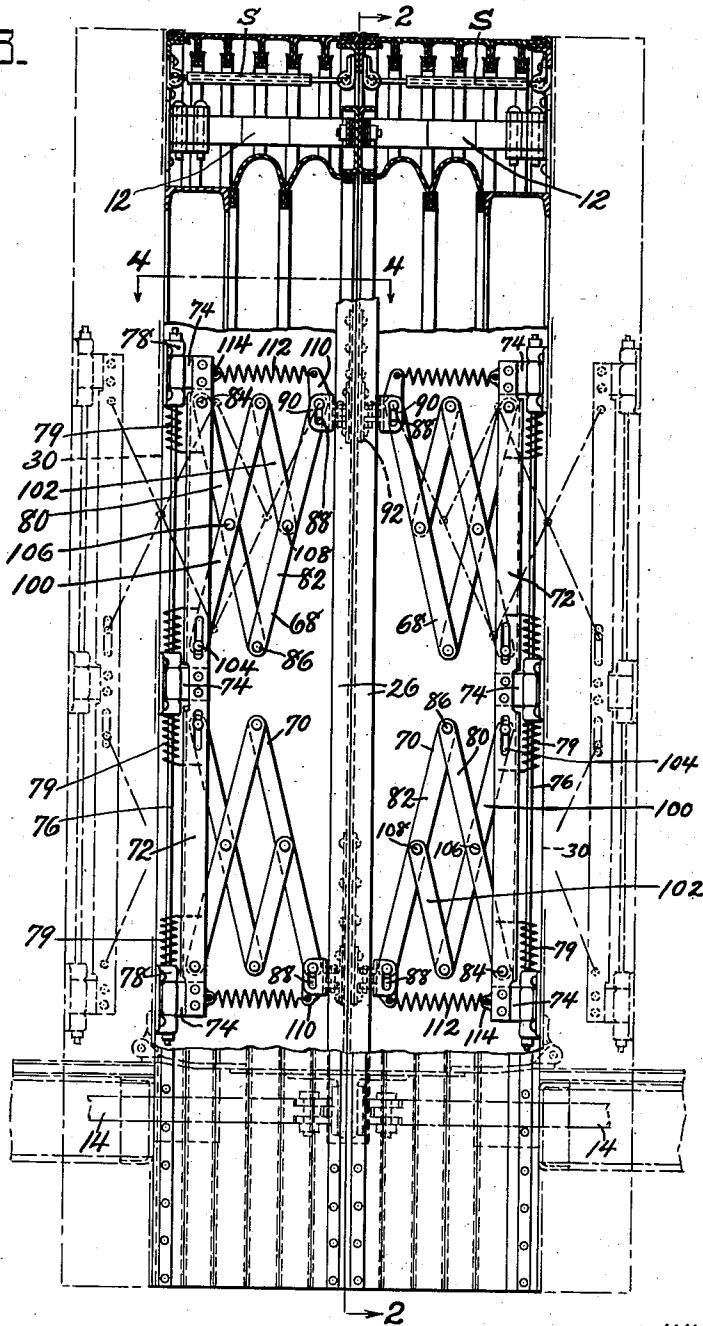

INVENTORS
John B. D. Thompson
Sigvald Udstad
BY Donald U. Rich
ATTORNEY

Sept. 27, 1938.

J. B. D. THOMPSON ET AL
RAILWAY CAR CONSTRUCTION

2,131,493

Filed April 12, 1935

4 Sheets-Sheet 4

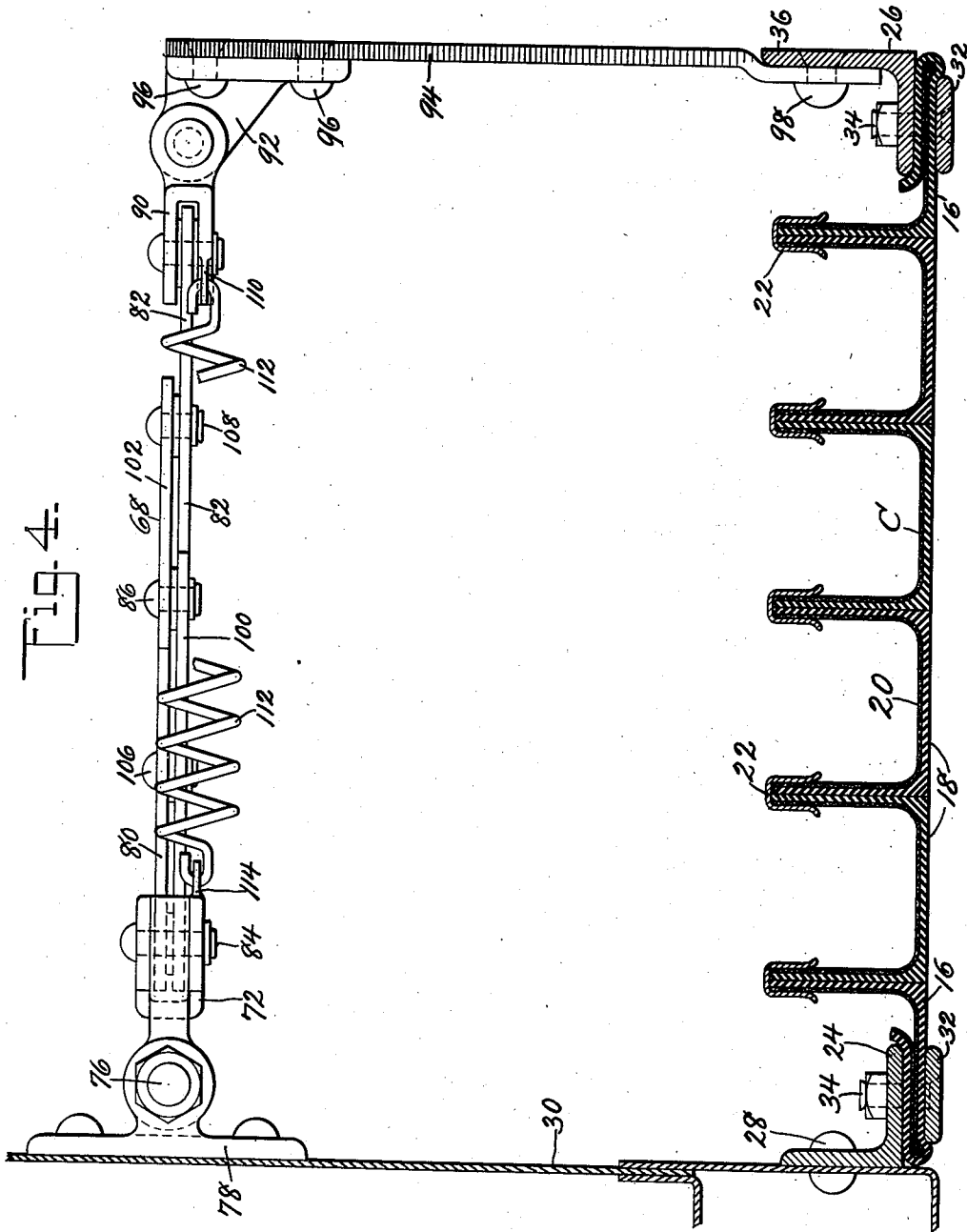

INVENTORS
John B.D. Thompson
Sigvald Ustvad
BY *Donald H. Rich*
ATTORNEY

UNITED STATES PATENT OFFICE

2,131,493

RAILWAY CAR CONSTRUCTION

John B. D. Thompson and Sigvald Udstad, Berwick, Pa., assignors to American Car and Foundry Company, New York, N. Y., a corporation of New Jersey

Application April 12, 1935, Serial No. 15,930

20 Claims. (Cl. 105—15)

This invention relates generally to railway passenger car construction and has particular reference to means for enclosing the space between the adjacent end portions of adjacent car bodies.

5 One object of this invention is to provide an enclosing arrangement between the adjacent end portions of adjacent car bodies which will be arranged in substantially the line of the side walls and roofs of the car bodies whereby a train will
10 present a substantially unbroken outer surface to eliminate the formation of air pockets which necessarily furnish wind resistance, said enclosing means being flexible and being suitably supported so as to be yieldable in accordance with
15 track curvatures.

Another object of this invention is to provide a streamlined car construction in which inner and outer flexible diaphragms are provided, the inner diaphragm constituting the vestibule diaphragm and defining a passageway between adjacent car bodies, and the outer diaphragm being
20 arranged in substantially the line of the side walls and roof of each of the car bodies and extending in substantially U form from one side of the
25 car to the other.

Still another object of this invention is the provision of new and improved means arranged between and connected to the adjacent end portions of adjacent car bodies and conforming thereto in shape and adapted to substantially
30 enclose the space between said bodies.

A further object of this invention is the provision of a new and improved flexible diaphragm for enclosing space between the adjacent end
35 portions of adjacent car bodies.

A still further object of this invention is the provision of new and improved means for supporting a flexible diaphragm which encloses the space between the adjacent end portions of adjacent
40 car bodies.

Other objects and advantages of this invention will be apparent from the following description taken in conjunction with the accompanying drawings in which:

45 Figure 1 is a sectional plan view of the end portions of adjacent car bodies showing the present invention applied thereto, the view also showing, in broken lines, the relative positions of certain parts when the car bodies assume a position in
50 which they are not longitudinally aligned.

Fig. 2 is a fragmentary end elevational view of one of the car bodies, the view being taken on the line 2—2, Fig. 3; the pantograph gate construction being omitted in order to disclose other
55 parts more clearly.

Fig. 3 is a side elevation of the adjacent end portions of adjacent car bodies, the view having certain parts broken away and other parts shown in section.

Fig. 4 is an enlarged view taken on the line 4—4, Fig. 3, showing only one of the two outer vestibule members with its associated support, and

Fig. 5 is an enlarged detail sectional view taken on the line 5—5, Fig. 2.

Referring now more particularly to the drawings in which similar characters of reference designate similar parts in the several views, Fig. 2 shows a fragmentary end elevation of a car body with which the present invention is adapted to
15 be associated, the body having a side wall and roof indicated at 2 and 4 respectively. The car illustrated is of streamline type and hence is devoid of sharp angles, the general construction being one in which the side wall and roof merge
20 gradually, by curved sections, into each other to provide a substantially unbroken surface.

As shown in Fig. 1, extending between the adjacent end portions of adjacent car bodies, the latter being indicated at A and B respectively, is
25 a passageway defined by inner vestibule diaphragms 6 connected to vestibule posts 8 and each provided with face plates 10 arranged in abutting relation and supported by upper and lower supports 12 and 14 respectively; Fig. 1
30 showing, diagrammatically, the lower supports while the upper supports are shown in Figs. 2 and 3. It will be obvious that any suitable or desired type of upper and lower support for the inner vestibule arrangement may be provided,
35 the face plates 10 being retained in abutting relation by means of said supports which, also, obviously function as expanders.

The present invention comprises a means for enclosing the space between the adjacent end
40 portions of adjacent car bodies, which means conforms generally to the contour of the car bodies and, as clearly shown in the drawings, this enclosing means comprises outer diaphragms indicated generally at C which are suitably supported
45 as presently to be described.

A diaphragm C is connected to each of the car bodies and is substantially U-shaped in plan so as to extend from one side of the car up and across the car and then down at the opposite
50 side of the car; these diaphragms conforming to the contour of the cars as will be apparent. The diaphragms connected to each of the car bodies are connected as described hereinafter and func-
55

tion as a unit to enclose the space between the car bodies.

These outer diaphragms C are more clearly indicated in section in Fig. 4 where it can be seen that each thereof is formed of a plurality of contiguously arranged flexible end and intermediate units designated at 16 and 18 respectively, each of which is lined as at 20 with suitable fabric such as canvas or the like. Adjacent units are connected by means of continuous clips 22 which may, if desired, be secured to said units in any suitable or desired manner, these clips being coextensive with the sections 16 and 18 of the diaphragm.

As shown clearly in Fig. 4, the end units 16 each have one leg rebent upon itself and secured to angles 24 and 26 respectively; angle 24 being riveted as shown at 28 to the end wall 30 of the car body. A retaining strip 32 is provided and the end unit 16 is secured between the angle 24 and said retaining strip by suitable fasteners such as the bolts 34. The opposite end unit 16 is connected to the angle 26 in a manner similar to that just described and hence the same reference characters are applied. The leg 36 of the angle 26 constitutes a diaphragm face plate as is clearly shown in Figs. 1 and 3 and is co-extensive with the diaphragm whereby to extend up one side and across and then down at the other side of the car.

The outer diaphragm is supported at its upper portion, as shown in Figs. 3 and 5, by means of upper supports indicated generally at S arranged on opposite sides of the longitudinal center line through the car bodies and each comprising a tubular sleeve 38 secured as by keys 40 to a cylindrical stem 42 projecting horizontally from a bearing element in the form of a ball 44 pivotally arranged in a socket 46 secured as by bolts 48 to the end wall of the car body. The socket 46 comprises a pair of bearing portions, one formed integral with the attaching portion 50 of the socket and being indicated at 52 while the complementary bearing portion is indicated at 54 and is detachably connected to the attaching portion 50 of the socket. As shown more clearly in Fig. 5, a socket 56 is secured to the angle 26 and constitutes a bearing for a ball 58 at one end portion of a stem 60 which is slidably arranged within the tube 38. The socket 56 is formed by an integral bearing portion 62 and a detachable but complementary bearing portion 64, the latter being secured to the socket 56 and to the angle 26 by suitable fasteners such as the bolts 66. As clearly shown in Fig. 3, an upper support S is provided for each of the outer diaphragm units C on opposite sides of the longitudinal center line through the car body. These supports S are so formed and arranged that in the event of downward sagging of the outer vestibule unit C the upper portions of the clips 22 may rest thereon though Fig. 3 shows a slight clearance between the supports S and said clips, this being the ideal construction.

From the description so far it can be seen that the outer vestibule diaphragms are provided with face plates in the form of angles which cooperate with each other and are preferably connected together in any suitable or desired manner whereby they may work in unison.

The present invention provides means for supporting the outer vestibule diaphragms through the medium of the cooperating face plate angles 26 and, as clearly shown in the drawings, each outer vestibule diaphragm is supported by upper

and lower pantograph gate arrangements indicated generally at 68 and 70 respectively.

The gate arrangements for supporting the outer diaphragm sections are identical and a description of one will suffice for both.

As clearly shown in Fig. 3, the upper and lower gates 68 and 70 respectively are each formed of a plurality of links connected together in such a manner as to be capable of automatic adjustment to conform with variations in the relative positions of the car bodies. This is shown clearly in broken lines in Fig. 1.

The gates 68 and 70 are pivotally connected to a gate standard 72 having bearing elements 74 by which it is hingedly connected with a hinge rod 76 supported in bearings on brackets 78 secured to the vestibule wall 30. The gates are normally retained in a plane normal to the vestibule wall 30 by means of springs 79 arranged on the hinge rod 76 and having one end of each thereof secured to the hinge rod brackets and the opposite end portions of said springs lapping and bearing against the gate standard 72.

The gates 68 and 70, as can be seen in Fig. 3, are oppositely arranged whereby the upper gate 68 functions to constantly exert an upward force on the diaphragm face plate 26, or in other words the face plate is supported on the upper gate while the connection between the lower gate and the diaphragm face plate is such that the diaphragm is, in effect, suspended therefrom.

The construction of the gates 68 and 70 is identical though they are arranged in respectively inverted positions, and referring again to Fig. 3, it can be seen that the upper gate 68 comprises a pair of connected links 80 and 82 respectively; link 80 having its upper end portion connected at a fixed pivot 84 to the upper end portion of the gate standard 72. The lower end portions of links 80 and 82 are pivotally connected together at 86 while the upper end portion of link 82 has a slidable pivoted connection in a slot 88 with a clevis 90 pivotally connected with an attaching bracket 92 to which a supporting arm 94 is securely fastened as by rivets 96. As clearly shown in Fig. 4 the supporting arm 94 extends from the bracket 92 to and is connected with the leg 36 of the outer diaphragm face plate angle 26 by suitable fasteners such as the rivets 98.

The gate 68 also includes a pair of links 100 and 102, the former having a slidable pivot connection at its lower end portion with the standard 72 as shown at 104 and extending upwardly and being pivotally connected intermediate its ends as shown at 106 with the link 80 at a point between the ends of the latter. The link 102 depends from the upper end portion of link 100 and is pivoted at its lower end as shown at 108 to the link 82 intermediate the ends of the latter.

As shown more clearly in Figs. 3 and 4, the clevis 90 is provided with an upstanding attaching arm 110 to which one end of a spring 112 is connected, the opposite end of said spring being connected at 114 to the gate standard 72.

As before mentioned, the upper and lower gates 68 and 70 respectively are identical in construction though relatively inverted and hence the same reference characters are applied to the lower gate 70 as have been applied to the gate, but it is to be noted that links 80 and 82 of the upper gate have the face plate supported thereon, while links 80 and 82 of the lower gate have the face plate suspended therefrom. This particular arrangement is provided in order that the slot 88 may be extended downwardly from

the bearing pin thus permitting the face plates to lift or slide as a unit relative to the gates to take care of relative vertical movements of the car body.

5 The respective face plates 26 may be connected in any suitable or desired manner as by bolts or the like which are removable in order to permit separation of the respective car bodies, and this rigid connection between the face plates necessitates the peculiar type of parallel motion devices previously described in order to provide for the relative car movement.

From the above description it is believed that the construction of the present invention will be fully apparent to those skilled in the art. The enclosing means for the space between the adjacent end portions of adjacent car bodies is so arranged as to be substantially alined with the side walls and roof of adjacent car bodies. The enclosing means comprises outer diaphragm sections which may be formed of extruded rubber; the form shown in the drawings being a plurality of contiguously arranged units, U-shaped in section and inwardly facing as shown in Figs. 1 and 4 whereby, upon variations in the relative positions of the car bodies, they are free to flex as shown in broken lines in Fig. 1. The enclosing means includes diaphragm face plates and the entire enclosing means is supported by the pantograph gate arrangements shown and described and also by the upper supports S. Pantograph gate arrangements for supporting the outer diaphragm construction provide an automatically adjustable or flexible construction well suited to the purpose for which it is designed and to which it is applied.

The drawings show certain embodiments of the invention but it is to be understood that they are for illustrative purposes only and various changes in the form and proportions of the construction may be made within the scope of the appended claims without departing from the spirit of the invention.

What is claimed is:

45 1. In combination with the adjacent end portions of adjacent car bodies, means closing the space between said end portions comprising a pair of contiguously arranged flexible and resilient diaphragms secured to the end portions and conforming to the contour of said car bodies whereby the diaphragms are normally held substantially alined with the side walls and roofs of said bodies, cooperating face plates secured to the contiguous portions of said diaphragms, automatically adjustable supporting elements secured to the car bodies adjacent the roofs thereof and connected with the upper portions of the face plates to support the resilient diaphragms, upper and lower pairs of pantograph gates secured to the end walls of each of said car bodies, and supporting arms extending from said gates to the side portions of the face plates for supporting said diaphragms.

65 2. Means for closing the space between the adjacent end portions of adjacent car bodies comprising adjacently arranged flexible diaphragms secured to the car bodies substantially in line with the side walls and roofs thereof and provided with abutting face plates, and a plurality of pairs of pantograph gates secured at each side of the car bodies and connected with the face plates to support the diaphragms at their side portions.

75 3. Means for closing the space between the adjacent end portions of adjacent car bodies com-

prising adjacently arranged flexible diaphragms secured to the car bodies substantially in line with the side walls and roofs thereof and provided with abutting face plates, a plurality of pairs of pantograph gates secured at each side of the car bodies and connected to the face plates to support the diaphragms at their side portions, and means secured to each car body adjacent the roof and connected with the upper portions of the face plates to support the diaphragms at said upper portions.

4. In railway car construction in combination with the adjacent end portions of adjacent car bodies, an inner flexible diaphragm construction constituting a passageway between said car bodies, an outer resilient diaphragm construction formed of a plurality of independent separably connected self-supporting elements each having the outer face of its sides and top portions arranged substantially in line with the side walls and roofs of the car bodies and forming when unflexed a substantially continuous surface therewith, and extensible and retractable means secured to the adjacent end walls of said car bodies and connected with the outer diaphragm to support the latter substantially in alignment with the side walls and roofs of the car bodies during the extension and retraction of said means.

5. In railway car construction, means for closing the space between the adjacent end portions of adjacent car bodies comprising a flexible diaphragm secured at one end portion to the car body and formed of a plurality of connected inwardly facing U-shaped resilient elements, a face plate secured to the opposite end portion of said diaphragm, extensible and retractable means secured to the end wall of said car body, and a supporting element connected to said means and extending and connected to said face plate.

6. In railway car construction, a diaphragm arrangement comprising a flexible element formed of a plurality of connected U-shaped resilient members, said diaphragm being secured at one end portion to the end wall of the car, a face plate secured to the opposite end portion of said diaphragm, a pantograph gate secured to the end wall of the car, and a diaphragm support extending between and connected to the gate and face plate.

7. In railway car construction, means for closing the space between the adjacent end portions of adjacent car bodies comprising a plurality of contiguously arranged connected resilient elements constituting a diaphragm arrangement extending between the car bodies and normally held substantially in line with the side walls and roofs thereof, said elements each being substantially U-shaped in section, and means capable of extension and retraction secured to the end walls of the car bodies and connected with the side portions of the diaphragm arrangement to support the latter.

8. In railway car construction, means for closing the space between adjacent end portions of adjacent car bodies comprising a resilient diaphragm arrangement formed of independent separably connected self-supporting elements extending between and connected with the car bodies and having their outer faces in substantial alignment with the side walls and roof thereof and forming when unflexed a substantial continuation thereof and including cooperating face plates, extensible and retractable means secured

to the car bodies and connected with the face plates to support the diaphragm arrangement at its side portions substantially in alignment with the side walls and roofs of the car bodies during movement of the diaphragm arrangement toward and away from the car ends, and means for supporting the diaphragm arrangement at its upper portion comprising extensible and retractable elements having their end portions pivotally connected to the face plates and car bodies respectively in such a manner as to be capable of substantially universal movement.

9. In combination with a railway car, a diaphragm secured to the end portion thereof substantially in line with the side wall and roof thereof and formed of a plurality of connected extruded rubber sections substantially U-shaped in section, a face plate secured to the outer edge portion of said diaphragm, and extensible and retractable elements secured to the end wall of the car body, and an arm pivotally connected with the free end portion of said elements and rigidly connected with the face plate to support the diaphragm.

10. Means for closing the space between the adjacent end portions of adjacent car bodies comprising, adjacently arranged flexible diaphragms secured to the car bodies substantially in line with the side walls and roofs thereof and provided with abutting face plates, and a plurality of pairs of pantograph gates secured at each side of the car bodies and connected with the face plates to support the diaphragms at their side portions, said face plates and gates having a pin and slot connection to permit relative vertical movements therebetween.

11. Means for closing the space between the adjacent end portions of adjacent car bodies comprising, adjacently arranged flexible diaphragms secured to the car bodies substantially in line with the side walls and roofs thereof and provided with abutting face plates, a plurality of pairs of pantograph gates secured at each side of the car bodies and connected to the face plates to support the diaphragms at their side portions, said face plates and gates having a pin and slot connection to permit relative vertical movements therebetween, and means secured to each car body adjacent the roof and connected with the upper portions of the face plates to support the diaphragms at said upper portions.

12. Means for closing the space between the adjacent end portions of adjacent car bodies comprising, adjacently arranged flexible diaphragms secured to the car bodies substantially in line with the side walls and roofs thereof and provided with abutting face plates, and a plurality of pairs of pantograph gates pivotally secured at each side of the car bodies and slidably connected with the face plates to support the diaphragms at their side portions for substantially vertical movement relative to the pantograph gates.

13. Means for closing the space between the adjacent end portions of adjacent car bodies comprising, adjacently arranged flexible diaphragms secured to the car bodies substantially in line with the side walls and roofs thereof and provided with abutting face plates, and means for supporting the diaphragms comprising a plurality of pairs of pantograph gates pivotally secured to each of the adjacent car bodies and slidably connected to the adjacent face plate to permit vertical movement thereof relative to the pantograph gates.

14. Means for closing the space between the adjacent end portions of adjacent car bodies comprising, adjacently arranged flexible diaphragms secured to the car bodies substantially in line with the side walls and roofs thereof and provided with abutting face plates, and means for supporting the diaphragms comprising a plurality of pairs of pantograph gates pivotally secured to each car body and slidably connected to the adjacent face plate to permit vertical movement thereof relative to the pantograph gates, and means securing said face plates together for movement in unison.

15. In a car construction, means closing the space between the adjacent end portions of adjacent car bodies comprising flexible elements each having sides and a top portion, each of said elements being formed of a plurality of independent connected contiguously arranged resilient members having their outer faces normally aligned respectively with the side walls and roofs of the car bodies and forming a substantially continuous surface therewith when not flexed, and extensible and retractable means extending from the end walls of the adjacent car bodies inwardly of said flexible elements and having connection therewith for supporting the latter substantially in alignment with the side wall and roofs of the car bodies during the extension and retraction of said means.

16. In a car construction, means closing the space between the adjacent end portion of adjacent car bodies comprising flexible elements each formed of a plurality of independent self-supporting connected contiguously arranged resilient members, each of said resilient members having the outer faces of their sides and top portion aligned respectively with the side walls and roofs of the car bodies and forming a substantially continuous surface therewith when not flexed, and extensible and retractable means extending from the end walls of the adjacent car bodies inwardly of said flexible element and having connection therewith for supporting the latter substantially in alignment with the side walls and roofs of the car bodies during the extension and retraction of said means.

17. In a car construction, means closing the space between the adjacent end portions of adjacent car bodies comprising flexible elements each formed of a plurality of independent self-supporting contiguously arranged, and separably connected resilient members each including sides and a top portion, said resilient members having their outer faces aligned respectively with the side walls and roofs of the car bodies and forming a substantially continuous surface therewith when not flexed, extensible and retractable parallel motion means secured to the end walls of the car bodies inward of said flexible members and each having connection with the side portions of said resilient members for supporting the latter substantially in alignment with side walls and roofs of the car bodies during the extension and retraction of said parallel motion means, and means extending from the end walls of the adjacent car bodies adjacent the roofs thereof and connected with the top portion of said resilient members to support the latter thereon at their top portion.

18. In a car construction, means closing the space between the adjacent end portions of adjacent car bodies comprising diaphragms connected to each car body, each diaphragm being formed of a plurality of resilient members U-

shaped in cross section, said sections being contiguously arranged with their normally abutting leg portions extending inwardly, and their outer faces positioned in substantial alignment with the side walls and roofs of the car bodies and forming a substantially continuous surface therewith when not flexed, means connecting the inner marginal abutting edges of said leg portions, and supporting means for said diaphragms extending from the end portions of said car bodies and connected with said diaphragms.

19. Means for closing the space between adjacent end portions of adjacent car bodies comprising, adjacently arranged flexible diaphragms secured to the car bodies substantially in line with the side walls and roofs thereof and provided with abutting face plates, a plurality of upper pantograph gates extending from each car body and having their outer extremities composed of upwardly extending links connected at their upper ends to one of said face plates, a

plurality of lower pantograph gates extending from each car body and having their outer extremities composed of downwardly extending links connected at their lower portion to one of said face plates, said face plates and pantograph gates being so formed and arranged as to permit relative vertical movement therebetween.

20. A diaphragm for closing the space between adjacent end portions of adjacent car bodies comprising a member connected to each car body, each member being formed of a plurality of resilient sections U-shaped in cross-section, said sections being contiguously arranged with their normally abutting leg portions extending inwardly and secured together adjacent their inner marginal edges and forming when unflexed a substantially continuous surface, whereby said sections are relatively separable at their outer edges to permit extension of said diaphragm.

JOHN B. D. THOMPSON. 20
SIGVALD UDSTAD.