

April 27, 1954

J. W. PATTON ET AL
BERTH PAN STRUCTURE

2,676,333

Filed July 30, 1948

4 Sheets-Sheet 1

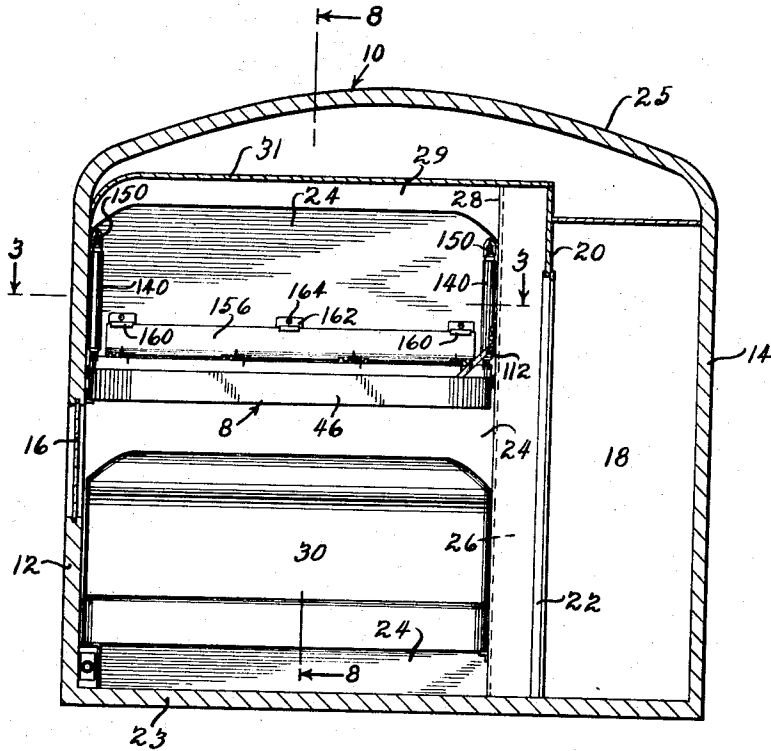

FIG. 1

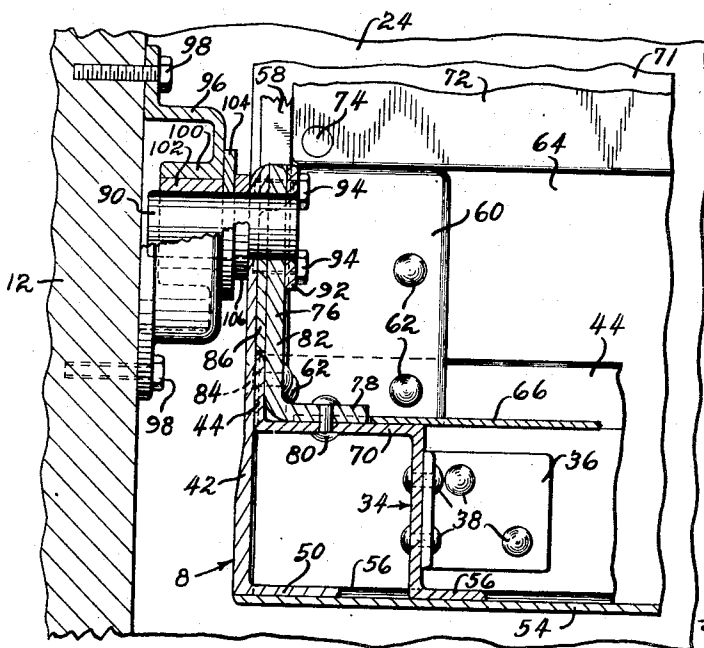

FIG. 2

INVENTORS
John W. Patton and
Cropper W. Holland Jr.
BY
George P. Ericson
ATTORNEY

April 27, 1954

J. W. PATTON ET AL
BERTH PAN STRUCTURE

2,676,333

Filed July 30, 1948

4 Sheets-Sheet 2.

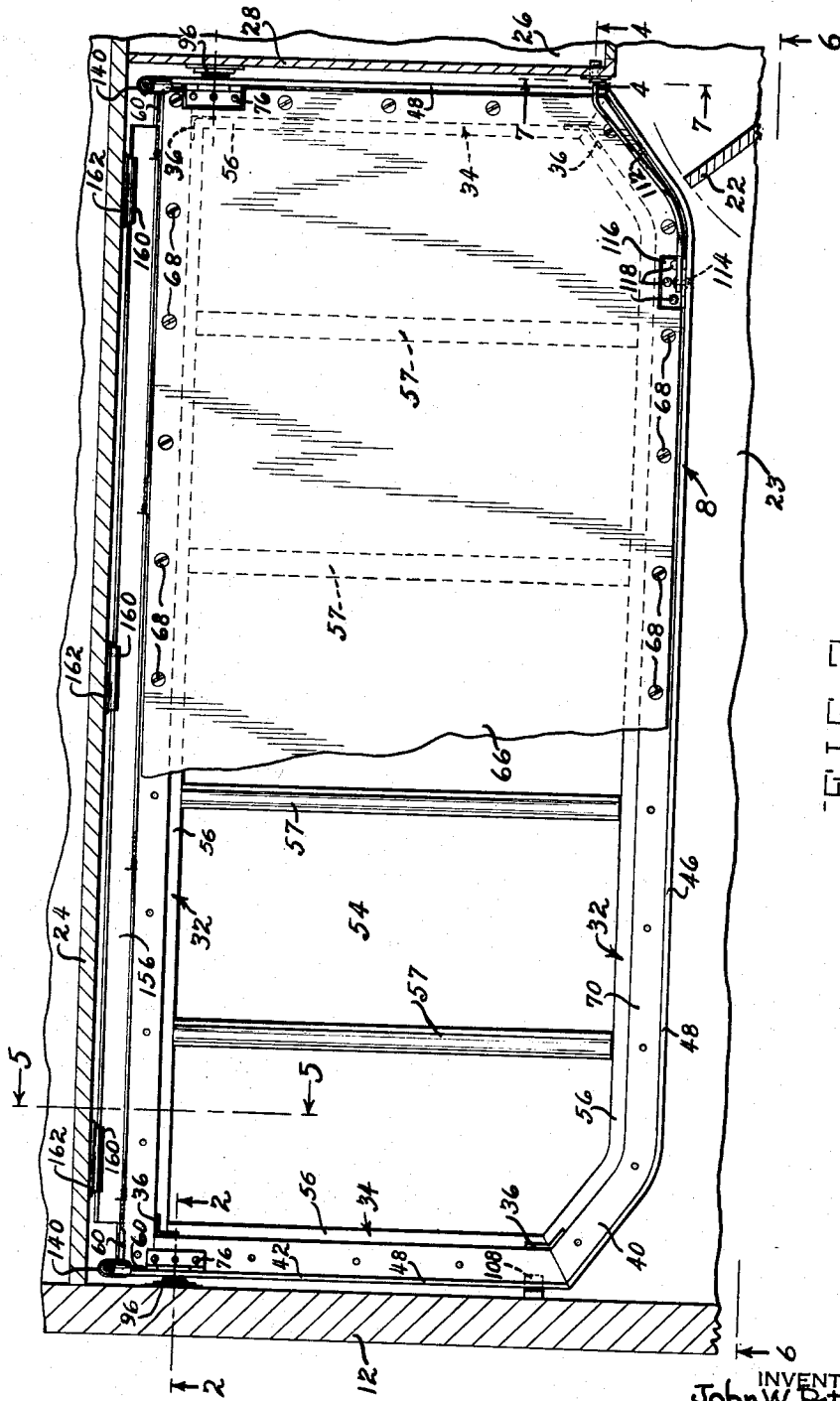

FIG. 3.

INVENTORS
John W. Patton and
Cropper W. Holland, Jr.
BY
George R. Ericson
ATTORNEY

April 27, 1954

J. W. PATTON ET AL

2,676,333

BERTH PAN STRUCTURE

Filed July 30, 1948

4 Sheets-Sheet 3

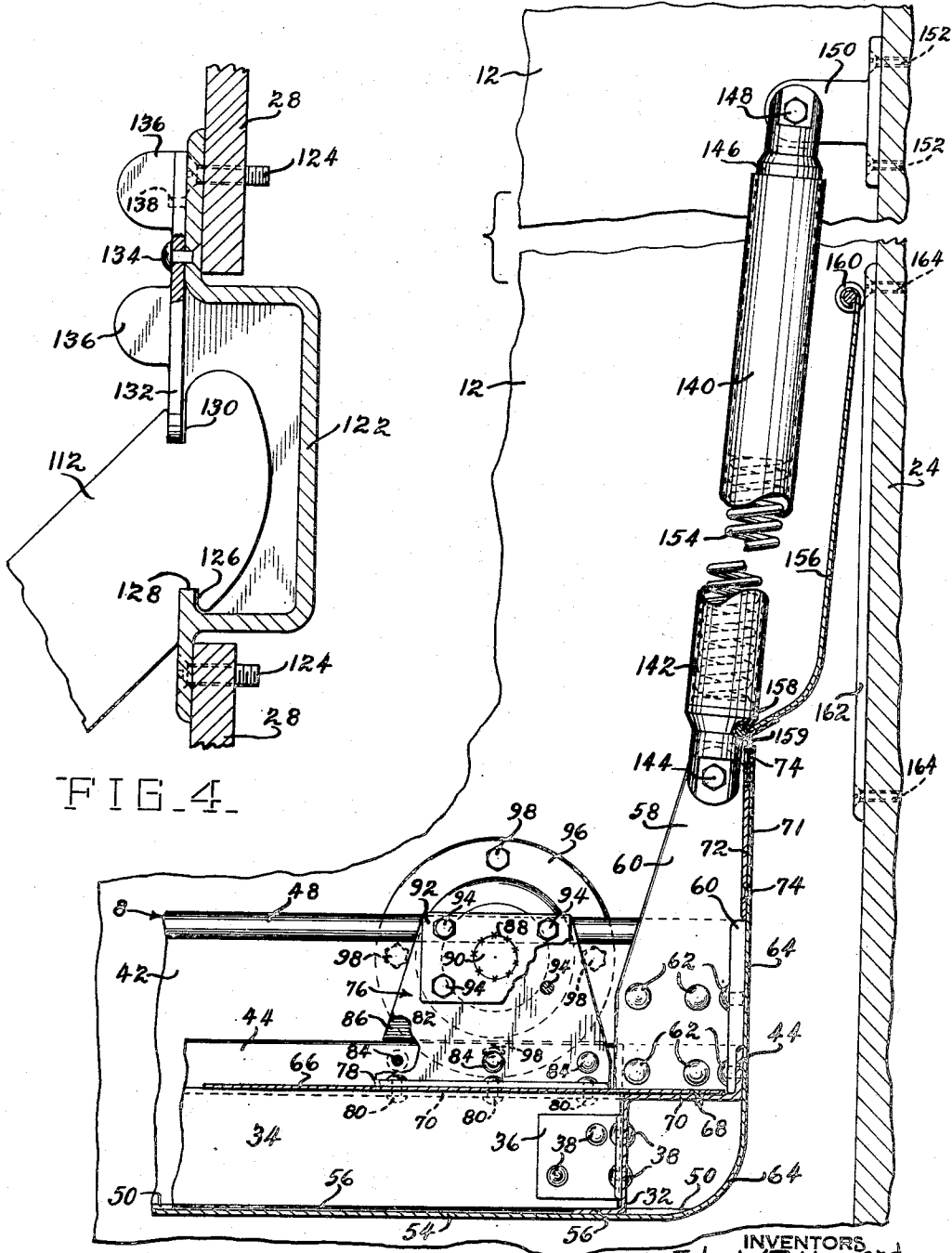

FIG. 4.

FIG. 5.

INVENTORS
John W. Patton and
Cropper W. Holland Jr.
By
George R. Ericson
ATTORNEY

April 27, 1954

J. W. PATTON ET AL
BERTH PAN STRUCTURE

2,676,333

Filed July 30, 1948

4 Sheets-Sheet 4

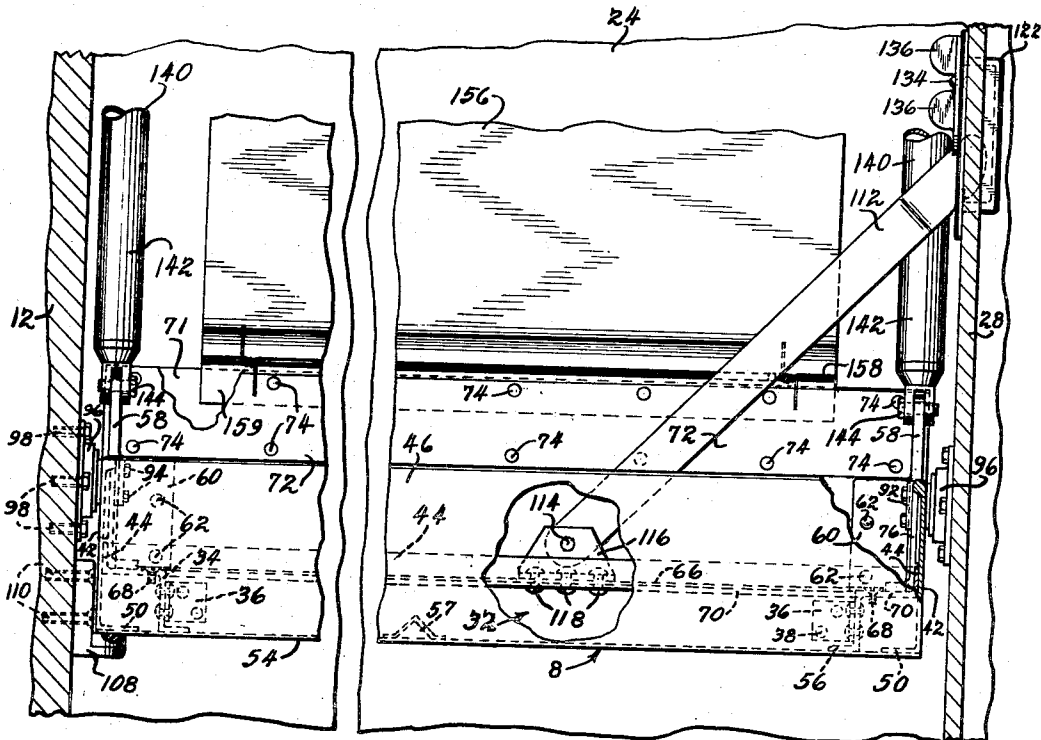

FIG. 6.

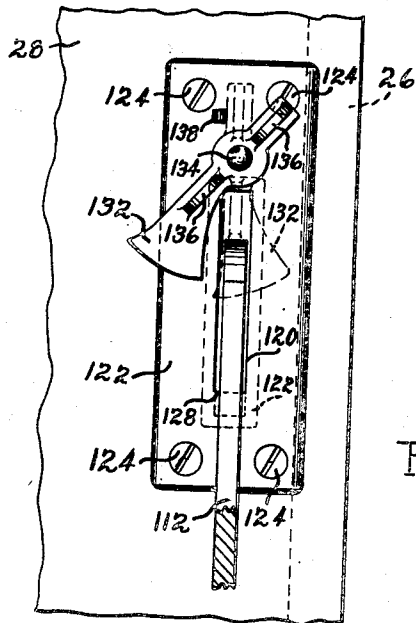

FIG. 7.

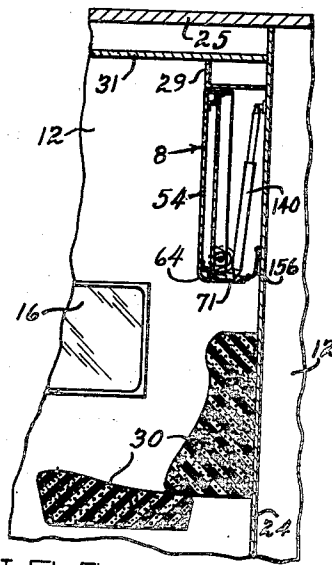

FIG. 8.

INVENTORS
John W. Patton and
Cropper W. Holland Jr.
BY
George R. Erickson
ATTORNEY

UNITED STATES PATENT OFFICE

2,676,333

BERTH PAN STRUCTURE

John W. Patton, Philadelphia, Pa., and Cropper W. Holland, Jr., New Milford, N. J., assignors to American Car and Foundry Company, New York, N. Y., a corporation of New Jersey

Application July 30, 1948, Serial No. 41,484

7 Claims. (Cl. 5—9)

1

This invention relates to berths and particularly to the structure of berth pans for folding berths used in sleeping car, ship or other small bedrooms.

The trend in modern sleeping car accommodations is toward the more general provision of private bedrooms equipped with one or more berths. A large number of these berths are of the folding type and may be mounted either crosswise or lengthwise of the car bedroom. Due to the particular conditions under which such berths are installed and used, the structure of the berth pan and its support are often important factors to be taken into consideration.

It is an object of this invention to provide a folding berth pan structure having a bottom cover plate that is extended to curve upwardly around its pivoted side to form an upstanding marginal side wall for the pan structure.

Another object of the invention is to provide a folding berth pan structure of the type described in which the extended portion of the bottom cover plate presents a smooth unbroken exterior finish surface for the lower side corner of the pan structure when in its stored position.

A further object of the invention is to provide a folding berth pan structure as above described in which the extended portion of the bottom cover plate is reinforced for attachment thereto of a bedding retainer for the berth structure.

These and other objects of the invention will be apparent to those skilled in the art from the following description taken with the accompanying drawings in which:

Figure 1 is a transverse sectional view taken through a sleeping car room showing the folding berth in prone position.

Figure 2 is an enlarged sectional view through the pivotal mounting for the berth taken on line 2—2 of Figure 3.

Figure 3 is a view taken on line 3—3 of Figure 1, part of the false bottom being broken away to better disclose the pan structure.

Figure 4 is an enlarged sectional view taken on line 4—4 of Figure 3 showing the releasable berth support engaged in the recess and slot means.

Figure 5 is a sectional view through the pivoted side of the berth taken on line 5—5 of Figure 3, certain parts thereof being broken away to better disclose other parts and the upper portion of the room walls being broken away and moved down to more clearly show the relationship and arrangement of the parts.

Figure 6 is a side elevational view taken on line 6—6 of Figure 3 and showing the folding berth in prone position.

2

Figure 7 is an enlarged front view of the recess and slot means taken on line 7—7 of Figure 3.

Figure 8 is a view taken on line 8—8 of Figure 1 but showing the berth in its vertical stored position.

Referring now more particularly to the drawings, the folding berth 2 is shown as installed in a sleeping car generally indicated at 10 having side walls 12, 14, window 16, side aisle 18, aisle wall 20 provided with a door 22, floor 23 and roof 25. The bedroom is bounded by the car side wall 12, aisle wall 20, transverse end wall 24 and a similar opposite transverse wall (not shown). The room is provided with a closet 26 extending part way along its aisle side between the aisle wall 20 and closet wall 28, and with a seat 30 of any suitable type such as that shown. The invention is shown as embodied in an upper crosswise berth installed in a side aisle car, but this is merely for purposes of illustration since it may also be embodied in lower berths or lengthwise berths and used in cars of the central aisle type.

The upper berth 2 is pivotally mounted between the car side wall 12 and closet wall 28 to fold between a horizontally extending prone position and a storage position where it extends vertically of the transverse wall 24. An overhanging canopy member 29 projects from the upper portion of the transverse wall 24 immediately beneath the room ceiling 31. The canopy member is shaped to conform to the contour of the swinging side of the berth and is of sufficient thickness to lie flush with the adjacent bottom of the berth when the berth is in the stored position to form therewith a substantially unbroken room wall surface.

The berth 2 comprises a pan structure formed of upstanding marginal end walls 42 with an upstanding marginal side wall 46 welded to one end thereof. The marginal side wall 46, which forms the side of the berth pan structure that is free to swing, is bent or bowed at its ends as shown at 48 in Figure 3 to provide clearance for opening of the door 22 when the berth is in prone position. This side wall is similarly bowed at both ends to permit interchangeable installation of the berth at opposite sides of the room, and for the sake of uniformity from the standpoint of manufacture and appearance. The marginal walls 42, 46 are preferably made of sheet metal formed with a bulb or beaded top edge 48 and with inwardly extending relatively short base

3

flanges 50 to the under faces of which is secured by welding a sheet metal bottom cover plate 54. At the pivoted side of the berth pan structure, as shown in Figure 5, the bottom cover plate 54 is continued to curve upwardly as indicated at 64 and extended beyond the top edges 48 of walls 42, 46 as indicated at 71, to form the opposite upstanding marginal side wall for the pan structure. The plate 54 thus in effect constitutes a flange integral with the side wall 64, 71 of sufficient length and width to extend beneath and be secured to the relatively short base flanges 50 of end walls 42 and the opposite side wall 46 to form the bottom cover of the berth pan. The pan structure is reinforced by side and end W-shaped angle members 32, 34, respectively, connected together at their adjacent ends by angle pieces 36 secured thereto by rivets 38 and having their upright flanges 44 welded to the inner faces of the upstanding marginal walls. The side angle member 32 at the free side of the pan structure is bent to conform with the contour of the bowed side marginal wall 46. The W-shaped angle members 32, 34 also have their horizontal flanges 56 welded to the inner face of the bottom cover plate 54, which is additionally stiffened by laterally extending ribs 57 of inverted V shape similarly welded to the inside face of the bottom cover plate.

Upstanding counterbalance anchor castings 58 having an angle-shaped base attaching portion 60 are secured by rivets 62 at the pivoted side of the berth pan to the inside of opposite corners formed by the upright flanges 44 of side and end angle members 32, 34, marginal end walls 42 and the extended portion 64 of bottom cover plate 54. The beaded edge 48 of the marginal end walls 42 is cut away at this region to permit proper application of the anchor castings 58, the attaching base portions 60 being formed to fit up against the upright flanges 44 of side and end angle members 32, 34 with their outer faces lying flush therewith. A false bottom plate 66 is removably attached by screws 68 to and supported on the horizontal legs 70 of the side and end angle members 32, 34. The part 71 of the extended portion 64 of bottom cover plate 54 extending beyond the top edge 48 of marginal end walls 42 is stiffened by a reinforcing plate 72 secured to its inner face by rivets 74 for a purpose later to be described.

The pivot pin mounting for the folding berth pan structure comprises a relatively heavy angle member 76 having its horizontal leg 78, as viewed in Figure 2, secured by rivets 80 to the horizontal leg 78 of opposite end angle members 34 adjacent the inner or pivoted side of the berth pan. The vertical leg 82 of these angle members 76 is secured by rivets 84 to the upright vertical flange 44 of end angle members 34 and to the marginal end walls 42. The pivot structure is reinforced by a spacer plate 86 interposed between the vertical leg 82 of member 76 and marginal end wall 42, each of which is formed with aligned openings, indicated at 88, for the reception of a pivot pin 90. The pivot pin is held in place by a retainer or anchor plate 92 welded to the inner end of the pin and secured to the pivot structure by bolts 94.

The pivot pins 90 are journaled in bearing members 96 secured by bolts 98 in the proper location on the opposite walls 12, 28 of the room. The bearing members are formed with a central cylindrical portion 100 lined with a bushing 102 through which the pins 90 extend. The berth pan structure is maintained in spaced relation to

bearing members 96 at opposite sides of the room by washers 104, 106 interposed between the bearing members 96 and the upstanding marginal end walls 42.

When the berth is in the horizontal prone position, its free side is supported at the outer end by a ledge member 108 secured by screws 110 to the car side wall 12, and at its inner end by a supporting link 112. The supporting link 112 is pivoted at one end, as indicated at 114 in Figure 6, to a bracket 116 secured by rivets 118 to the horizontal leg 70 of bowed side angle member 32. The link 112 is bent, as shown in Figure 3, to conform generally to the contour of the bowed end portion of the swingable side of the berth pan structure, with its opposite or free end adapted to be inserted through a slot 120 formed in recess casting 122 secured by screws 124 to closet wall 28. As shown in Figure 4, the free end of link 112 is provided at one side with a notch 126 engageable with the upstanding lip 128 forming the bottom of slot 120 in the recess casting 122 to releasably support the swingable side of the berth when it is in prone position. The free end of link 112 is also formed at its opposite side with a second notch 130 with which a latch member 132 pivoted at 134 to recess casting 122 is adapted to be engaged for retaining the link in berth supporting position. The latch member 132 is provided with finger actuated handle portions 136 and a stop 138 formed on recess casting 122 for limiting pivotal movement of the latch beyond notch engaging position.

The berth pan structure is equipped with counterbalance devices, one at each end of the pivoted side of the berth, and generally indicated at 140. The counterbalance devices each comprise a tubular part 142 pivoted at 144 to the anchor castings 58 and a cylindrical part 146 pivoted at 148 to bracket 150 secured by screws 152 to the transverse room wall 24. These parts are arranged in telescoping relation with a coil spring 154 interposed between them, the spring being installed under sufficient initial compression to exert a force capable of counterbalancing the weight of the berth structure and permit its easy and controlled operation. The berth structure is also provided at its pivoted side with a bedding retainer 156 pivotally connected by means of a piano type spring hinge 158 to the upper edge portions of bottom cover plate extension 71 and reinforcing plate 72. The upper edge portion of reinforcing plate 72 is cut away or recessed, to permit sandwicing of the bottom leaf 159 of hinge 158 between the plate 72 and cover plate extension 71, where it is secured in place by rivets 74. The bedding retainer 156 is held in operative position by rollers 160 carried thereby and riding on wear strips 162 secured by screws 164 to transverse wall 24.

The berth structure may be retained in its stored position by any suitable or desired type of latch means, but such means has not been shown or described since it forms no part of the present invention.

The invention may be modified in various respects as will occur to those skilled in the art and exclusive use of all modifications as come within the scope of the appended claims is contemplated. The claims to the support and mounting for the berth pan structure of the present application are contained in our copending divisional application Serial No. 170,854 filed June 28, 1950.

What is claimed is:

1. A berth pan structure comprising upstand-

5

6

ing means formed to provide one portion of a peripheral wall therefor having a bottom flange extending inwardly from the wall, and plate means having one portion thereof secured to said bottom flange and forming a bottom cover for the pan structure, the other portion of said plate means extending upwardly above the top of and cooperating with said upstanding means to form the remaining portion of the peripheral wall.

2. A berth pan structure comprising upstanding means forming one portion of a peripheral wall therefor, plate means having one portion secured to the bottom of said upstanding means and forming a bottom cover for the pan structure, the other portion of said plate means extending upwardly above the top of and cooperating with said upstanding means to form the remaining portion of the peripheral wall, and reinforcing means secured to the upwardly extending portion of said plate means above the top of said upstanding means to provide for an attachment for a bedding retainer.

3. A berth pan structure comprising upstanding side and end walls having inwardly extending bottom flanges, one of said side walls extending beyond the tops of said end walls and the opposite side wall, the bottom flange of said extending side wall being of sufficient length and width to extend beneath and be secured to the other of said bottom flanges to form a bottom cover for the pan structure.

4. A berth pan structure comprising upstanding side and end walls, said end walls and one of said side walls each being provided with an inwardly extending relatively short bottom flange, the other of said side walls extending beyond the tops of said end walls and first-named side wall, and a relatively long inwardly extending bottom flange on said other side wall extending beneath and secured to said short bottom flanges to form a bottom cover for the pan structure.

5. A berth pan structure comprising upstanding end walls, an upstanding side wall secured to said end walls at one side of the pan structure, a plate member secured to the bottoms of said side wall and end walls forming a bottom cover for the pan, said plate member having a portion extending upwardly around and above the tops

of and secured to said end walls at the opposite side of the pan structure to form the other upstanding side wall, and W-shaped reinforcing members connected together at their ends and having one leg thereof secured to the inner faces of said upstanding walls and another leg thereof secured to the portion of said plate member forming the bottom cover for the pan.

6. A berth pan structure comprising upstanding end walls and a side wall each having a bottom flange extending inwardly therefrom, and plate means having one portion thereof secured to said bottom flanges of said upstanding end walls and side wall forming a bottom cover for the pan structure, the other portion of said plate means extending upwardly above the tops of and cooperating with said upstanding end walls to form the opposite upstanding side wall of said berth pan structure.

7. A berth pan structure comprising upstanding side and end walls having inwardly extending bottom flanges, the bottom flange of one of said side walls being relatively short and forming a right angle therewith, the bottom flange of the other of said side walls being curved transversely along one edge and of sufficient length and width to extend beneath the other bottom flanges to form a bottom cover for the pan structure, and means securing said bottom cover flange to the other bottom flanges.

References Cited in the file of this patent

UNITED STATES PATENTS

Number	Name	Date
711,466	Bronson	Oct. 21, 1902
787,797	Schliepmann	Apr. 18, 1905
847,582	Johnson	Mar. 19, 1907
957,240	Naugle	May 10, 1910
1,359,637	Tranis et al.	Nov. 23, 1920
2,224,727	Friede	Dec. 10, 1940
2,229,608	Ragsdale et al.	Jan. 21, 1941
2,297,602	Woller	Sept. 29, 1942
2,531,687	Jones	Nov. 28, 1950
2,541,540	Patton	Feb. 13, 1951

FOREIGN PATENTS

Number	Country	Date
30,488	Germany	Feb. 25, 1885