

Oct. 6, 1925

1,556,000

J. J. McBRIDE  
DISCHARGE VALVE FOR TANKS

Filed June 9, 1922

2 Sheets-Sheet 1

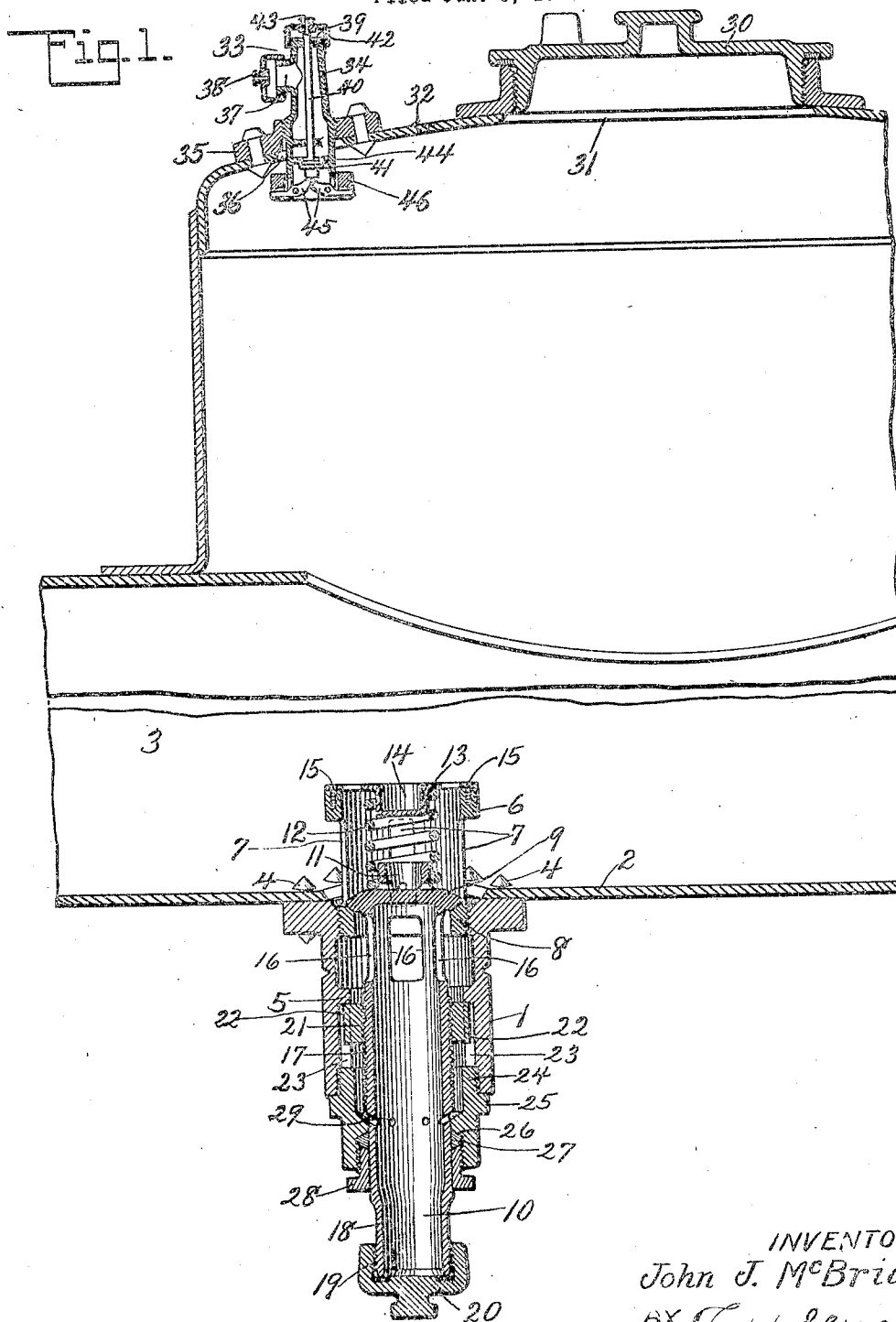

INVENTOR:  
John J. McBride  
BY T. H. Gibbs,

ATTORNEY.

Oct. 6, 1925.

1,556,000

J. J. McBRIDE

DISCHARGE VALVE FOR TANKS

Filed June 9, 1922

2 Sheets-Sheet 2

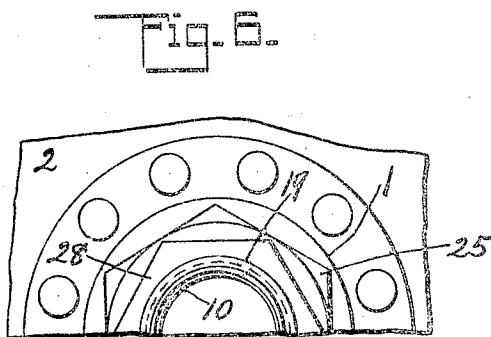
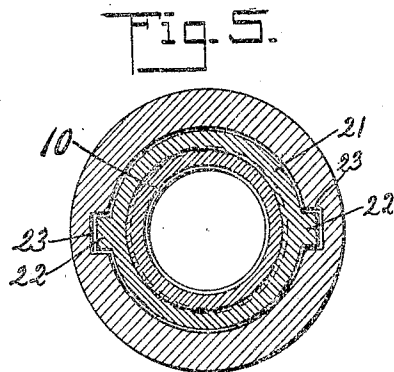
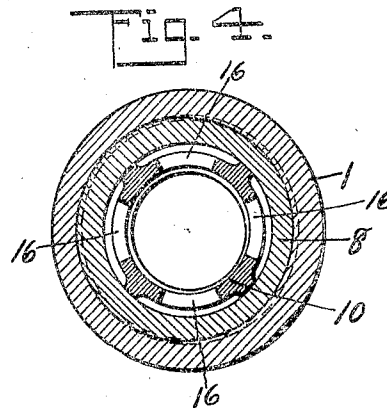
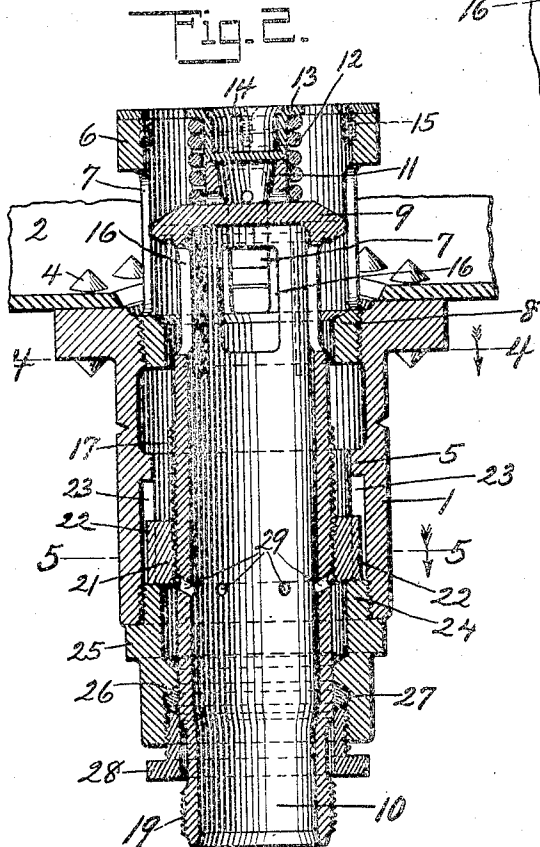
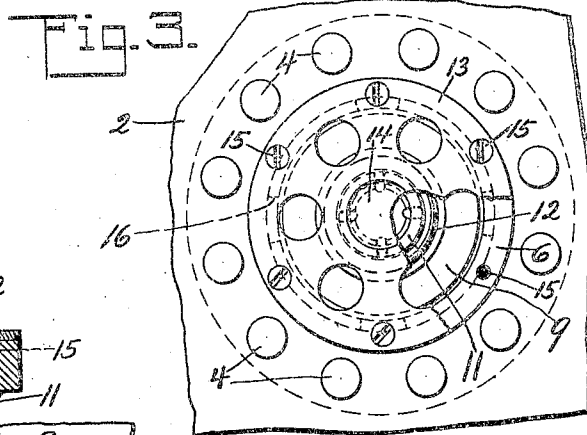

INVENTOR:  
John J. McBride  
BY *F. H. Gibbs*  
ATTORNEY.

# UNITED STATES PATENT OFFICE.

JOHN J. McBRIDE, OF BAYONNE, NEW JERSEY, ASSIGNOR TO AMERICAN CAR AND  
FOUNDRY COMPANY, OF NEW YORK, N. Y., A CORPORATION OF NEW JERSEY.

## DISCHARGE VALVE FOR TANKS.

Application filed June 9, 1922. Serial No. 567,045.

*To all whom it may concern:*

Be it known that I, JOHN J. McBRIDE, residing at Bayonne, Hudson County, State of New Jersey, and being a citizen of the United States, have invented certain new and useful Improvements in a Discharge Valve for Tanks, of which the following is a full, clear, and exact description, such as will enable others skilled in the art to which it appertains to make and to use the same, reference being had to the accompanying drawings, which illustrate the preferred form of the invention, though it is to be understood that the invention is not limited to the exact details of construction shown and described, as it is obvious that various modifications thereof within the scope of the claims will occur to persons skilled in the art.

In said drawings:

Fig. 1 is a broken central vertical section of a portion of a car tank showing my improved discharge valve applied thereto, the valve being shown in closed position;

Fig. 2 is a central vertical section of my discharge valve, the valve being shown in open position,

Fig. 3 is a top plan view of my discharge valve applied to a car tank, parts being broken away to show other parts more clearly;

Figs. 4 and 5 are sections taken on the lines 4-4 and 5-5, respectively, of Fig. 2; and

Fig. 6 is a partial bottom plan view of my discharge valve applied to a car tank.

It is an object of my invention to provide an improved discharge valve for car tanks that may be operated from outside of the tank. It is also an object of my invention to provide a discharge valve of the self-grinding type that may be operated upon the connecting and disconnecting of the discharge conduit to the valve.

With these and other objects in view, my invention comprises a flanged discharge outlet casing 1, secured to a sheet 2 of a tank 3 by rivets 4. The outlet casing 1 is internally screw-threaded at each end and, intermediate its ends, is provided with a shoulder 5. Threaded into the tank end of the casing 1 is a tubular valve cage 6 slotted so as to provide discharge openings 7 and having a valve seat 8 adapted to receive a valve 9. The valve 9 is provided with a tubular stem

10, which serves as a discharge outlet for the tank, and an annular projection 11, the projection 11 being adapted to engage a spring 12 which is confined between the valve 9 and a perforated cap or plate 13 which has a depressed lug 14 adapted to guide the other end of the spring 12 and is secured to the valve cage 6 by screws 15.

The tubular valve stem 10 is slotted, close to the valve 9, to provide openings 16 and has a screw threaded portion 17 at its center while its outer end portion 18 is of slightly reduced diameter and is threaded as at 19 to receive a cap 20. Engaging the threaded portion 17 of the stem 10 is a threaded collar 21 having projections 22 which slidably engage in slots 23 and keep the collar 21 from turning. Rotating the valve 9 will, therefore, cause the collar 21 to travel on the stem 10 the movement of the collar 21 being limited in one direction by engagement with the shoulder 5 and in the other direction by engagement with a stop 24 threaded into the other end of the casing 1. The stop 24, which has a shoulder 25 adapted to engage the casing 1, serves as a packing gland and has an inwardly projecting tapering shoulder 26 against which a packing 27 is compressed by the packing gland nut 28. Openings 29 in the stem 10 serve to drain the casing 1.

As my valve is to be operated without removing the usual manhole cover 30 provided for the opening 31 in the dome head 32, I provide an automatically operated valve 33 adapted to admit air to the tank as the tank contents are withdrawn. The valve 33 comprises a casing 34 mounted in a collar 35 riveted about an opening 36 in the dome head 32. The casing 34 is tubular and has an angularly disposed outlet 37 having a perforated cap 38. One end of the casing 34 is closed by a wall 39 having an opening to receive the valve stem 40 of the valve 41 and carries a cap 42 having an opening to receive the reduced end 43 of the stem 40. The valve 41 controls an opening in a wall 44 in the casing 34 and is normally held in closed position by levers 45 which are pivotally supported from the casing 34 and are operated by the annular weight 46.

In the operation of my device, assuming the valve 9 in closed position and the tank 3 loaded, the cap 20 is removed and the discharge pipe connected to the valve stem 10

10 by a coupling of the usual type. When the discharge pipe is fully connected to the stem 10, continued rotation of the coupling in the same direction will cause the stem 10 to rotate and the valve 9 to be rotated upon its seat 8, grinding the valve to its seat, and the collar 21 will be caused to travel along the stem 10 until the projections 22 engage the stop 24 whereupon the stem 10 will travel relatively to the collar 21 and the valve 9 will be raised from its seat 8 allowing the contents of the tank to be discharged through openings 7 in the valve cage 6, openings 16 in the stem 10 and the stem 10 to the discharge pipe. As the contents are discharged from the tank, a partial vacuum is created in the tank and air enters the valve casing 34 through the perforated cap 38 and, raising valve 41 from its seat against the resistance of the weighted levers 45, passes into the tank. If desired, the valve 41 may be held in open position by screwing down the cap 43.

With the valve in open position, rotating the coupling in the opposite direction will cause the stem 10 to travel in the collar 21 until the valve 9 engages the seat 8 whereupon the valve 9 will rotate upon its seat 8, grinding the valve to its seat, and the collar 21 will travel on the stem 10 until the projections 22 engage the shoulder 5, locking the valve 9 to its seat and preventing further rotation of the valve 9 on its seat 8. With the valve 9 locked to its seat, continued rotation of the coupling will disconnect the discharge pipe from the valve stem 10.

What I claim is:

1. In a tank discharge valve, a casing adapted to be secured to the tank, a valve cage having a valve seat carried by said casing, a valve adapted to engage said seat, a discharge outlet carried by said casing adapted to force said valve to its seat upon rotation of said valve.
2. In a tank discharge valve, a casing adapted to be secured to the tank, a valve cage having a valve seat carried by said casing, a valve adapted to engage said seat, a

discharge outlet carried by said valve and means engaging said outlet and casing adapted to raise said valve from its seat upon rotation of said valve.

3. In a tank discharge valve, a casing adapted to be secured to the tank, a valve cage having a valve seat carried by said casing, a valve engaging said seat, a discharge outlet carried by said valve, a cap carried by said cage and means engaging said cap and valve adapted to hold said valve to said seat.

4. In a tank discharge valve, a casing adapted to be secured to the tank, a valve cage having a valve seat carried by said casing, a valve in said cage adapted to engage said seat and carrying a discharge outlet and means adapted to operate said valve upon a predetermined rotation of said outlet.

5. In a tank discharge valve, a casing adapted to be secured to the tank, a valve cage having a valve seat carried by said casing, a valve in said cage adapted to engage said seat and carrying a discharge outlet and means engaging said outlet and casing adapted to raise said valve after a predetermined rotation of said valve upon said seat.

6. In a tank discharge valve, a casing adapted to be secured to the tank, a valve case having a valve seat carried by said casing, a valve in said cage adapted to engage said seat and carrying a discharge outlet and a collar engaging said casing and outlet and causing operation of said valve upon rotation of said outlet.

7. In a tank discharge valve, a casing adapted to be secured to the tank, a valve case having a valve seat carried by said casing, a valve in said cage adapted to engage said seat and carrying a discharge outlet, means adapted to operate said valve upon a predetermined rotation of said outlet and means exerting pressure on said valve during the rotation of said valve upon said seat.

In witness whereof I have hereunto set my hand.

JOHN J. McBRIDE.

10  
15  
20  
25  
30  
35  
40  
45  
50  
55  
60  
65  
70  
75  
80  
85  
90