

No. 626,601.

Patented June 6, 1899.

J. H. FARRELL.
TRIPLE VALVE.

(Application filed Mar. 17, 1899.)

(No Model.)

2 Sheets—Sheet 1.

FIG. 1.

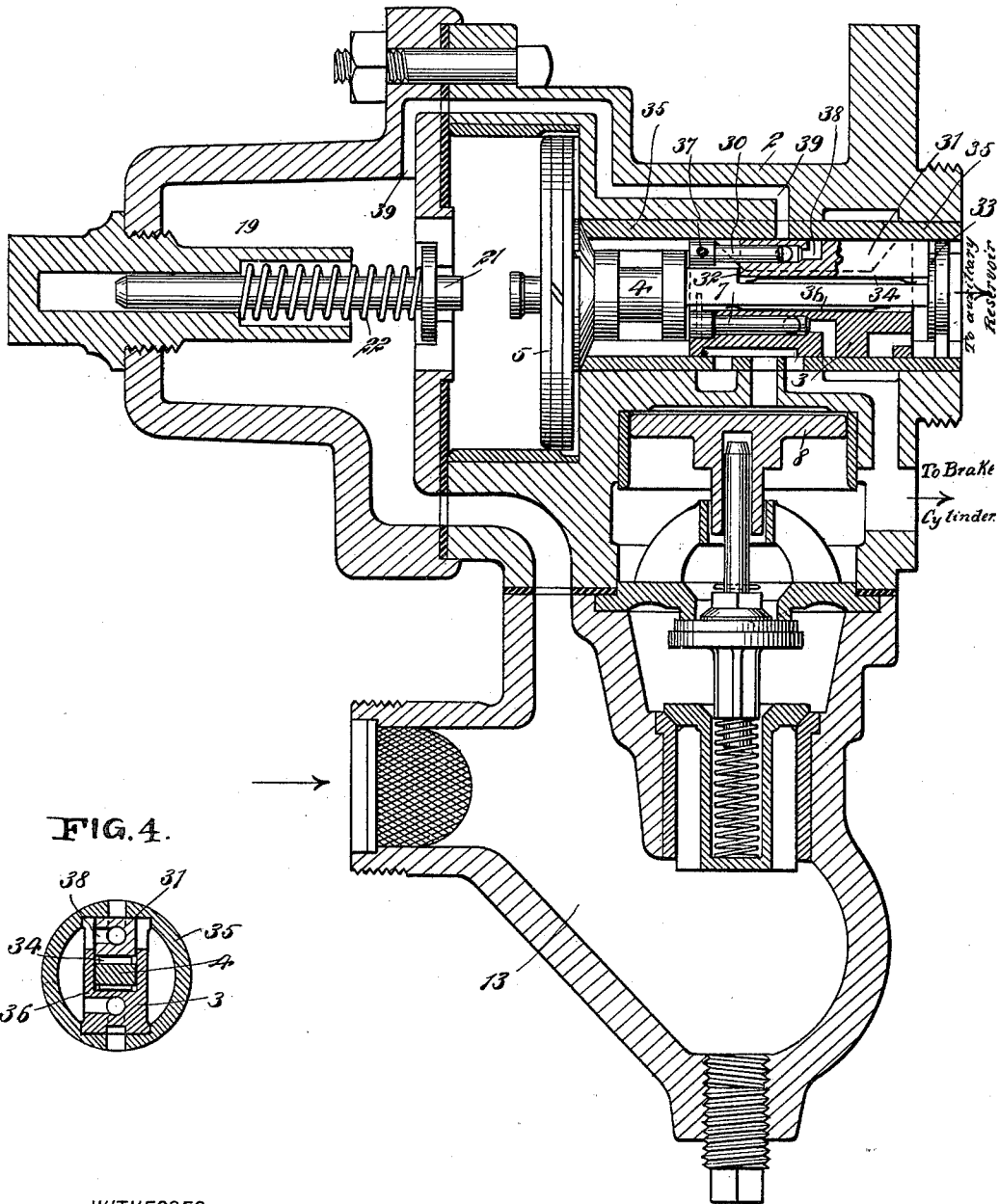
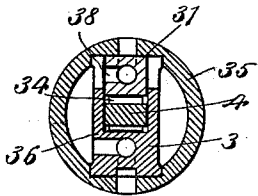

FIG. 4.



WITNESSES:

Donn Twitchell
Geo. H. Foster

INVENTOR

James H. Farrell.

BY

Mum

ATTORNEYS.

No. 626,601.

Patented June 6, 1899.

J. H. FARRELL.
TRIPLE VALVE.

(Application filed Mar. 17, 1899.)

(No Model.)

2 Sheets—Sheet 2.

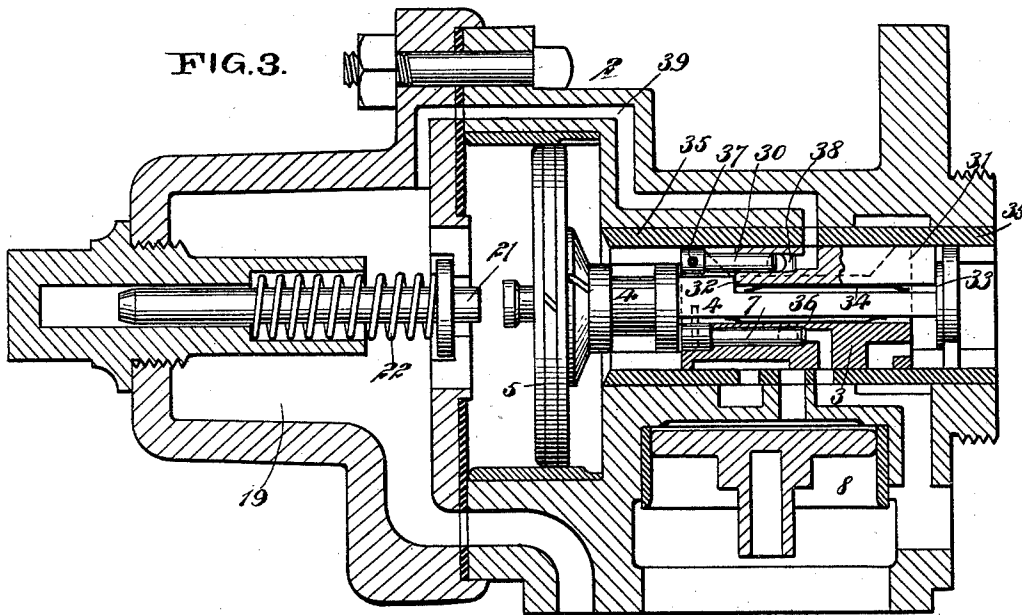
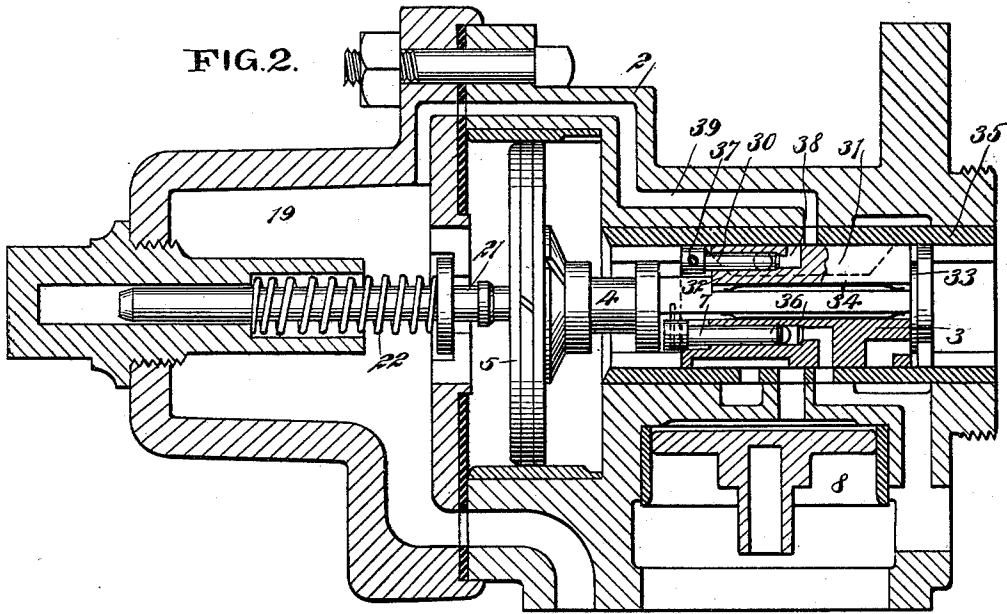

WITNESSES:

Donn Twitchell
Neof. Horner

INVENTOR

James H. Farrell

BY *[Signature]*

ATTORNEYS.

UNITED STATES PATENT OFFICE.

JAMES H. FARRELL, OF HARRISBURG, PENNSYLVANIA.

TRIPLE VALVE.

SPECIFICATION forming part of Letters Patent No. 626,601, dated June 6, 1899.

Application filed March 17, 1899. Serial No. 709,442. (No model.)

To all whom it may concern:

Be it known that I, JAMES H. FARRELL, of Harrisburg, in the county of Dauphin and State of Pennsylvania, have invented certain
5 new and useful Improvements in Triple Valves, of which the following is a full, clear, and exact description.

The invention relates to fluid-pressure brakes of the Westinghouse type; and its object is to provide certain new and useful improvements in triple valves whereby the reservoir can be recharged while the brakes are applied without releasing the brakes and whereby the engineer has complete control
15 of the braking power, especially when descending heavy grades or holding a heavy train at a station on a steep grade.

The invention consists of novel features and parts and combinations of the same, as will be fully described hereinafter and then pointed out in the claims.

A practical embodiment of my invention is represented in the accompanying drawings, forming a part of this specification, in which
25 similar characters of reference indicate corresponding parts in all the views.

Figure 1 is a sectional side elevation of the triple valve with the improvement applied and with the triple valve in release position.

Fig. 2 is a similar view of part of the same in position when applying the brake. Fig. 3 is a like view of the same in position with the brakes applied and with the auxiliary reservoir recharged from the train-pipe, and

Fig. 4 is a cross-section of the slide-valve casing and the piston-stem.

On the triple-valve body 2 are secured the usual train-cup 19 and the check-valve case 13, connected with the train-pipe, and the said triple-valve body 2 has also the usual connections with the auxiliary reservoir and the brake-cylinder, as indicated in the drawings. The slide-valve 3 controls the usual ports for making connections with the auxiliary reservoir, the brake-cylinder, the open air, and the chamber for the emergency-valve piston 8, and said slide-valve 3 is actuated in the usual manner by the stem 4 of the slide-valve piston 5. In the slide-valve 3 is arranged the usual graduating-valve 7, moving with the stem 4 and controlling the port connecting the auxiliary reservoir with the brake-

cylinder. The ports thus far described are of the ordinary construction and have the same functions as those in the triple valves
55 now in use.

A valve 30 is mounted to slide in a second slide-valve 31, held between shoulders 32 and 33 on the piston-stem 4, said slide-valve 31 being pressed by a spring 34 in contact with
60 its seat on the top of a slide-valve casing 35, and a separate spring 36 serves to press the slide-valve 3 in contact with its seat in the bottom of the casing 35. The valve 30 is attached by a transverse pin 37 to the side
65 flanges of the slide-valve 3, so that said valve 30 moves with the slide-valve 3, but the slide-valve 31 moves at all times with the stem 4 of the slide-valve piston 5. The valve 30 controls a port 38 in the slide-valve 31, and
70 this port 38 opens at one side into the valve-casing 35, thus making connection with the auxiliary reservoir, and said port 38 is adapted to register with a port 39, arranged in the
75 triple-valve body 2 and the train-cup body 19, the port 38 opening into the train-cup to make connection with the train-pipe by way of the check-valve casing 13.

When the triple valve is in release position, as shown in Fig. 1, the valve 30 is open,
80 while the valve 7 is closed, and when the engineer applies the brakes by reduction of pressure in the train-pipe in the usual manner and the piston 5 moves to the left, as shown in Fig. 2, to establish communication
85 by way of the slide-valve 3 between the auxiliary reservoir and the brake-cylinder then the stem 4 in moving to the left carries the slide-valve 31 along, the port 38 moving beyond the port 39 with the valve 30 in a closed
90 position, so that no communication is established between the port 39, port 38, and the interior of the valve-casing 35 during the time the slide-valve 31 shifts to the left, as described.

When the auxiliary reservoir has charged the brake-cylinder with air and the brakes are applied and the pressure in the auxiliary reservoir is reduced by the expansion of the air into the brake-cylinder, then the piston 5
100 moves slightly to the right, as shown in Fig. 3, and in doing so the stem 4 moves the graduating-valve 7 into a closed position in the slide-valve 3, as the latter remained station-

ary during this travel of the piston 5 to the right, and at the same time the stem 4 shifts the slide-valve 31 to the right to bring the port 38 in register with the port 39, and as the valve 30 remains stationary with the slide-valve 3, to which it is attached, it is evident that the movement to the right of the slide-valve 31 causes the valve 30 to open the port 38 to establish communication between the train-pipe and the auxiliary reservoir, so that the train-pipe pressure can pass from the train-pipe through the check-valve case 13, train-cup 19, port 39, port 38, and valve-casing 35 to the auxiliary reservoir to recharge the latter to full train-pipe pressure while the auxiliary reservoir is cut off from the brake-cylinder by the graduating-valve 7. Now if a reduction of braking power in the brake-cylinder takes place owing to leakage or other cause and the train on a downgrade gains more and undesirable speed in consequence of such reduction then the engineer makes another reduction of train-pipe pressure to again cause the piston 5 to move to the left by the pressure from the auxiliary reservoir until the piston 5 again reaches the position shown in Fig. 2—that is, abuts against the stem 21 of the graduating-spring 22. During this movement of the piston 5 to the left the slide-valve 31 is carried along by the stem 4, and the port 38 is thus moved out of register with the port 39, and at the same time the slide-valve 31 moves sufficiently to the left to bring the seat for the valve 30 to the latter to close the port 38. Furthermore, during this movement of the piston 5 to the left the stem 4, carrying the graduating-valve 7, moves the latter away from its seat to again establish communication between the auxiliary reservoir and the brake-cylinder to replenish the braking power in the brake-cylinder from the auxiliary reservoir without a release of the brakes. Should the braking power in the brake-cylinder again decrease and the train gain more speed, then the above-described operation is repeated—that is, as soon as the engineer notices that his train gains in speed he makes another reduction in the train-pipe pressure for the purpose above described. This can be repeated as many times as desired during the descent on a grade, thus enabling the engineer to fully control the train as to speed on a steep grade. If the engineer desires, he can release the brakes in the usual way to bring the several parts back to the

position shown in Fig. 1 and then immediately apply the brakes to full auxiliary-reservoir pressure.

The device is equally serviceable on triple valves for passenger-cars as well as for freight-cars, and is especially serviceable on downgrades to keep the train to the desired speed no matter what leakage takes place in the brake-cylinder during the application of the brakes and also to hold the train at a standstill at a station located on a steep grade.

The valve 3 is intermittently moved from the piston-stem 4, and the valve 31 and graduating-valve 7 move bodily at all times with the said stem 4, and as the valve 30 is bodily carried by the slide-valve 3 it is evident that when the graduating-valve 7 is open the valve 31 is closed, and vice versa.

Having thus fully described my invention, I claim as new and desire to secure by Letters Patent—

1. A triple valve provided with a slide-valve, a graduating-valve in the slide-valve, a slide-valve piston, and two auxiliary valves of which one is carried by the said slide-valve and the other by the stem of the said piston, the said auxiliary valves controlling a communication between the train-pipe and the auxiliary reservoir to recharge the latter to full train-pipe pressure at the time the brakes are applied.

2. A triple valve, provided with a slide-valve moving bodily with the slide-valve piston, and having a port for establishing communication between the auxiliary reservoir and the train-pipe when the brakes are applied, and a valve in said second slide-valve and moving with the triple-valve slide-valve, said valve controlling the port in said second slide-valve, substantially as shown and described.

3. A triple valve provided with a slide-valve, a piston for moving said slide-valve, a graduating-valve in said slide-valve for controlling the communication between the auxiliary reservoir and the brake-cylinder, a second slide-valve moving bodily with the stem of the said piston, and a valve carried by said first-named slide-valve and controlling the port in said second slide-valve, substantially as shown and described.

JAMES H. FARRELL.

Witnesses:

FERGUSON E. TRACY,
HARRY F. MATTER.