

E. M. HERR.
RETAINING VALVE.
APPLICATION FILED JULY 30, 1904.

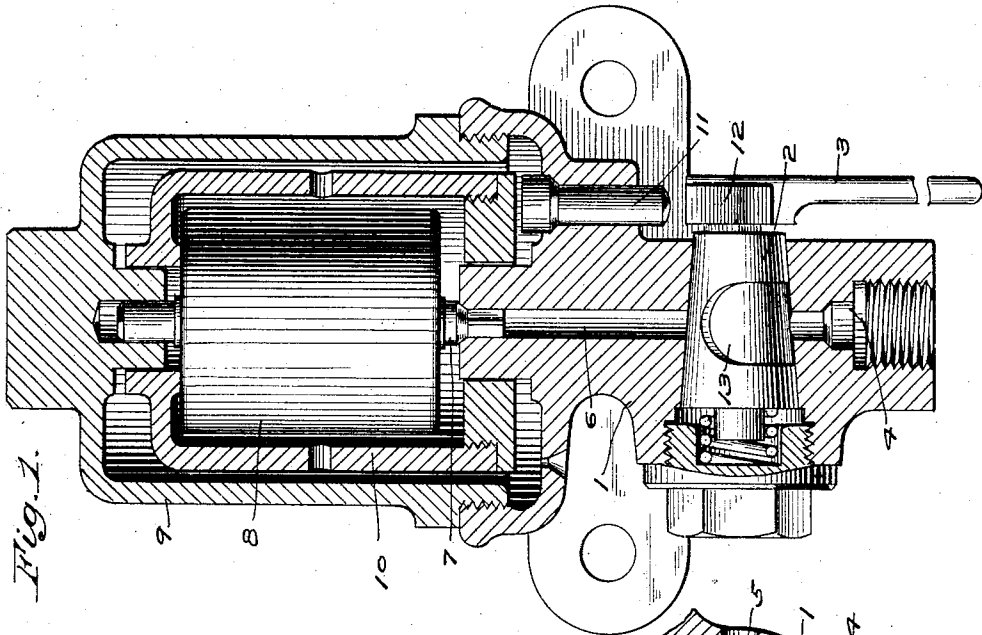

Fig. 1.

Fig. 3.

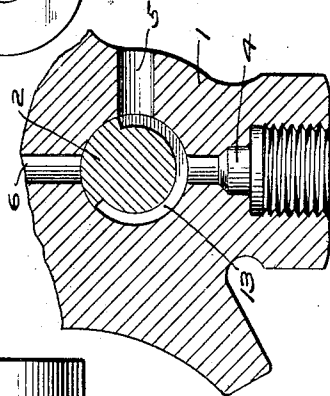
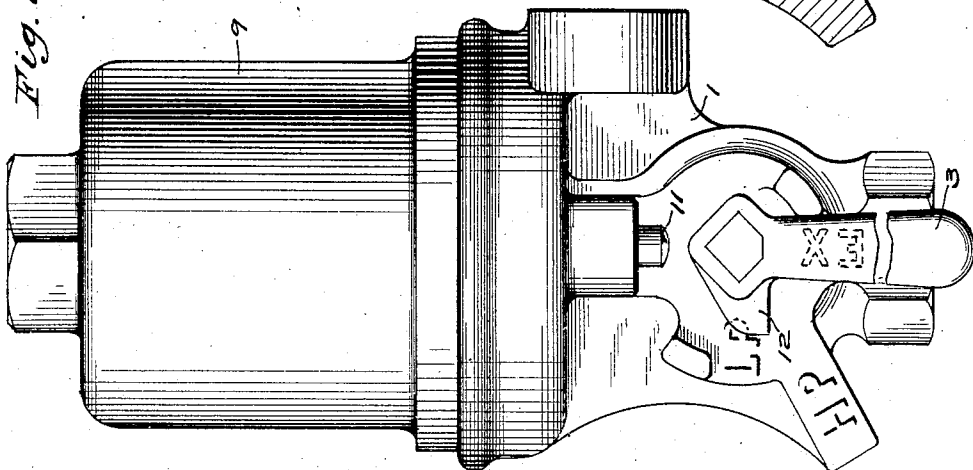

Fig. 2.



WITNESSES

J. A. Custer
Jas. B. MacDonald

INVENTOR

Edwin M. Herr
by Wright

Att'y.

UNITED STATES PATENT OFFICE.

EDWIN M. HERR, OF EDGEWOOD PARK, PENNSYLVANIA, ASSIGNOR TO
THE WESTINGHOUSE AIR BRAKE COMPANY, OF PITTSBURG, PENN-
SYLVANIA, A CORPORATION OF PENNSYLVANIA.

RETAINING-VALVE.

SPECIFICATION forming part of Letters Patent No. 786,288, dated April 4, 1905.

Application filed July 30, 1904. Serial No. 218,840.

To all whom it may concern:

Be it known that I, EDWIN M. HERR, a citizen of the United States, residing in Edgewood Park, county of Allegheny, and State of Pennsylvania, have invented a certain new and useful Improvement in Retaining-Valves, of which the following is a specification.

This invention relates to retaining-valves, and is particularly adapted to be used in connection with an automatic fluid-pressure brake system for controlling the exhaust from the triple valves.

In the present standard air-brake apparatus as applied to freight-cars the retaining-valve is usually mounted at the end of a pipe connected to the triple-valve exhaust-port and comprises a weighted valve and a cock adapted in one position to open the triple-valve exhaust to the atmosphere and in another position to close the outlet from the pipe to the atmosphere except through the weighted valve, whereby a certain pressure corresponding to the weight on the valve may be retained in the brake-cylinder while the triple valve is moved to release position and the auxiliary reservoir is recharged.

In heavy freight service, and especially on long grades, it is often desirable to be able to retain either one of two or more different degrees of pressure in the brake-cylinder, according to the weight of the load upon the car, and it has heretofore been proposed to provide a plurality of weights with separate means for throwing the same onto or off from the valve, and thereby vary the amount of pressure which may be retained in the brake-cylinder. In order to set such retaining-valve, however, it has been necessary to operate two handles, one for turning the cock and another for adjusting the weights, which is an objectionable feature, since the brakemen whose duty it is to set the retainers on the cars are instructed to note the position of the cock-handle, but would pay little attention to a separate adjusting device. Consequently it would be difficult to secure a proper adjustment of the weights.

The principal object of the invention is to

provide a retaining-valve having a cock and a loaded valve with means operated by the movement of the cock-handle for varying or adjusting the effective load on the valve.

Another feature of the invention relates to the location of one weight within another, whereby a compact and desirable form of retaining-valve device is produced.

Other features and objects will hereinafter appear from the following description and the accompanying drawings, in which—

Figure 1 is a sectional view of one form of retaining-valve device embodying my improvements; Fig. 2, a side elevation, and Fig. 3 a transverse section of the cock with the upper part of the device broken away.

According to the construction shown the device comprises a casing 1, having a cock 2, handle 3, port 4 leading to pipe connection of the triple-valve exhaust, port 5 leading to the atmosphere, port 6 leading to valve 7, having weight 8 inclosed by cap 9, mounted on the casing 1, all of which corresponds substantially with the present standard retaining-valve construction.

According to my invention I provide additional means operated by the movement of the cock-handle for varying the effect of the load on the valve or the force with which the valve is held to its seat, whereby different degrees of pressure may be retained in the brake-cylinder, according to different movements or positions of the handle. Various forms of mechanism within the scope of my invention may be devised for this purpose; but as a preferred construction I have shown an additional weight 10, adapted to be applied to the valve or raised off from the same by means of the pin 11, actuated by the cam 12, carried by the handle 3. This additional weight is preferably made in the form of a hollow cylinder inclosing the other weight, 8, and provided with openings at top and bottom, into which extend projections from the cap and casing to serve as guides for the weight. By means of this construction a very compact form of device is produced which is only slightly larger than the present standard retaining-valve.

When the handle of the cock is turned down to its normal exhaust position, (marked "EX,") the port 13 in the cock connects ports 4 and 5 in the casing, and thereby establishes free open communication from the triple-valve exhaust to the atmosphere. When the train is about to descend a long grade, the customary practice is for the brakemen to turn up the handles of the retaining-valves to the horizontal position, in which the port to the atmosphere is closed by the cock and the triple-valve exhaust is connected with the port leading to the weighted valve. This feature is also retained in my improved form of valve device, for when the handle is turned to its horizontal position (marked "LP") the cam 12 engages the pin 11 and pushing up the same raises the additional weight 10 off from the weight 8 and valve 7 and holds said weight 10 suspended in its elevated position, in which it has no effect upon the valve. The valve is then held to its seat by the ordinary weight 8, which is adapted to retain a pressure of about fifteen pounds per square inch in the brake-cylinder, which is sufficient for ordinary service with light or empty cars; but with a train of loaded cars or upon such cars as are loaded the handles are set in another or intermediate position, (marked "HP,") in which the port 5 is closed and ports 4 and 6 are connected through port 13 in the cock, while at the same time the mechanism, such as the cam and pin, operated by the cock-handle does not support the additional load or weight 10, which now rests upon the weight 8 and adds its effect to hold the valve 7 closed. The additional load may be as heavy as desired to retain a greater pressure in the brake-cylinder upon the loaded cars during the operation of recharging the auxiliary reservoirs when the triple valves are moved to release position for this purpose.

With this improved construction it will now be apparent that while only the ordinary brake-cylinder pressure is retained upon the light or empty cars by turning up the handle of the cock to its usual position during the operation of recharging the auxiliary reservoirs by merely setting the handle to another position a much higher brake-cylinder pressure may be retained, whereby an efficient braking force is retained on the loaded cars

and perfect control is secured over the speed of heavy trains in descending long grades.

Having now described my invention, what I claim as new, and desire to secure by Letters Patent, is—

1. A pressure-retaining valve device comprising a cock and a loaded valve with means operated by the movement of the cock for varying the effect of the load on the valve.

2. A pressure-retaining valve device comprising a cock, a valve having a plurality of load devices, and means operated by the movement of the cock-handle for shifting one of said load devices.

3. A pressure-retaining valve device comprising a cock, a valve having a plurality of weights, and mechanism operated by the movement of the cock-handle for supporting one of said weights independently of the valve.

4. A pressure-retaining valve device comprising a weighted valve, a cock for controlling ports leading to the atmosphere and to said valve, and means operated by the movement of the cock for adjusting the effect of the weight upon the valve.

5. A pressure-retaining valve device comprising a cock, a valve having a plurality of weights, and a cam operated by the cock-lever for supporting one of said weights independently of the valve.

6. A pressure-retaining valve device comprising a cock and a valve having a plurality of weights, one weight being located within another.

7. A pressure-retaining valve device comprising a cock and a valve having a plurality of weights, one weight being located within another, and means for supporting one weight independently of the valve.

8. A pressure-retaining valve device comprising a cock, a valve having two weights, one being in the form of a hollow cylinder surrounding the other, and means operated by the movement of the cock-handle for supporting the outer weight independently of the valve.

In testimony whereof I have hereunto set my hand.

EDWIN M. HERR.

Witnesses:

R. F. EMERY,

JAS. B. MACDONALD.