

No. 636,471.

Patented Nov. 7, 1899.

P. SYNNESTVEDT.
TRIPLE VALVE MECHANISM.

(Application filed Oct. 29, 1898.)

(No Model.)

2 Sheets—Sheet 1.

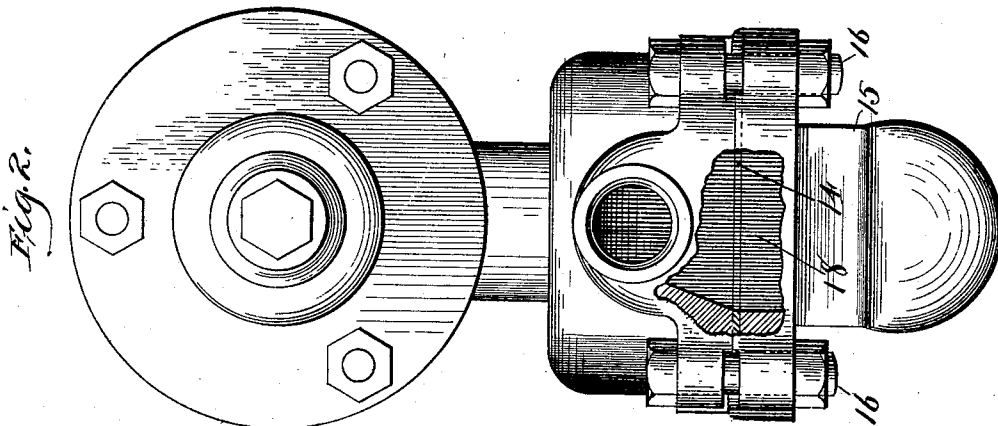
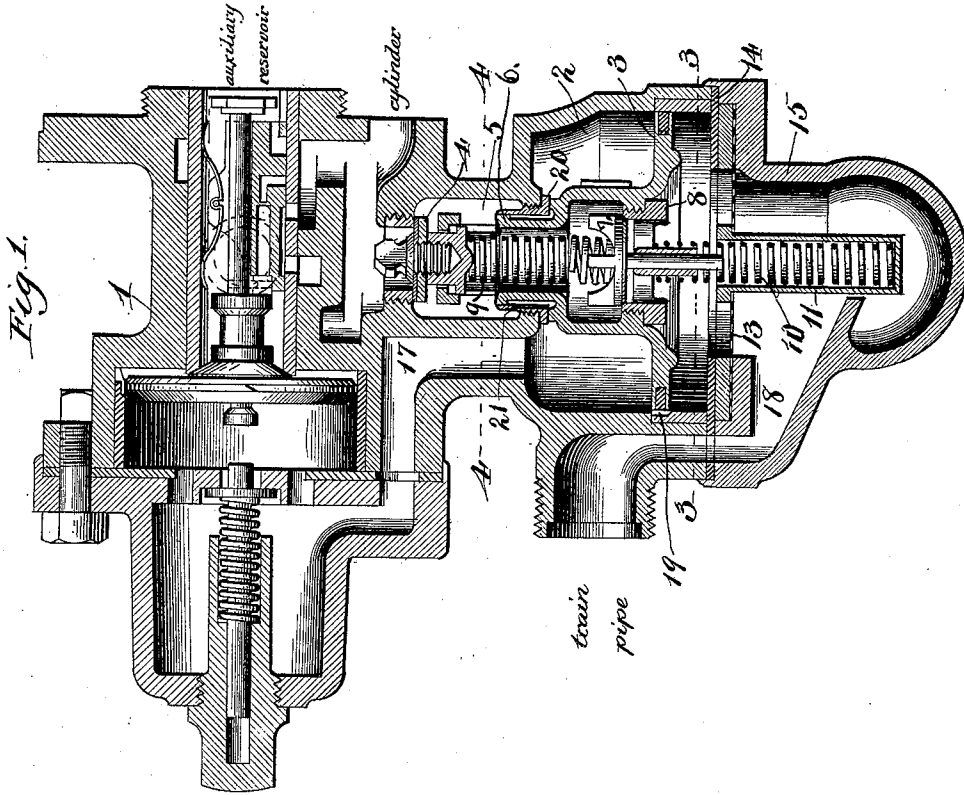

Witnesses
W. C. Collins
Martin H. Olsen,

Inventor
Paul Synnestvedt

No. 636,471.

Patented Nov. 7, 1899.

P. SYNNESTVEDT.
TRIPLE VALVE MECHANISM.

(Application filed Oct. 29, 1896.)

(No Model.)

2 Sheets—Sheet 2.

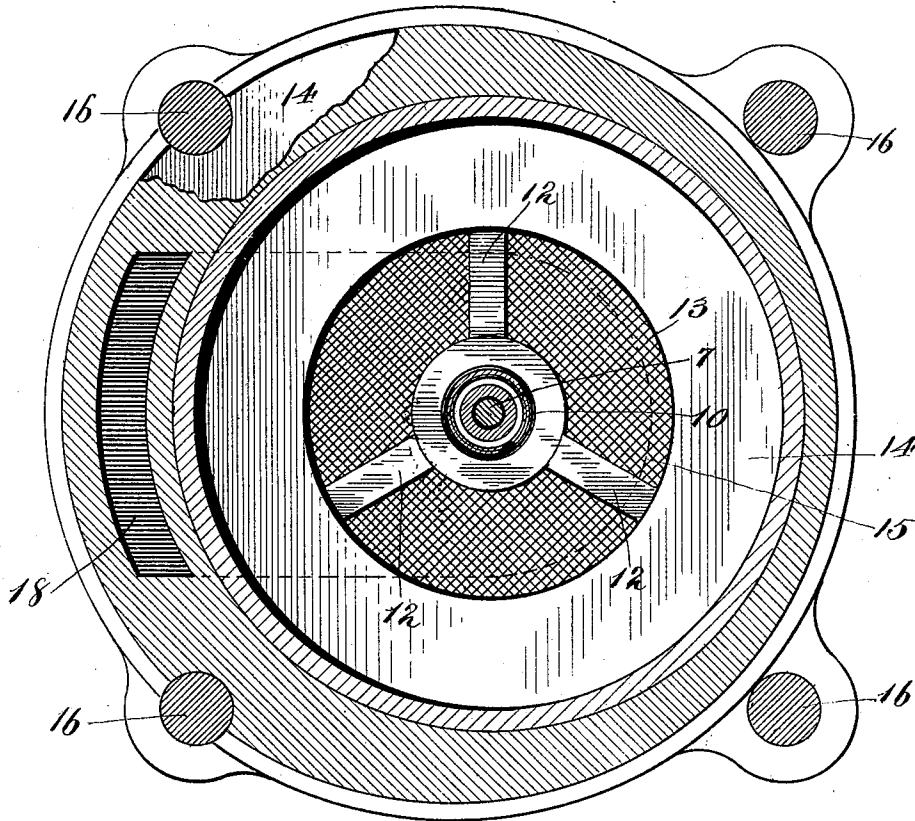

Fig. 3.

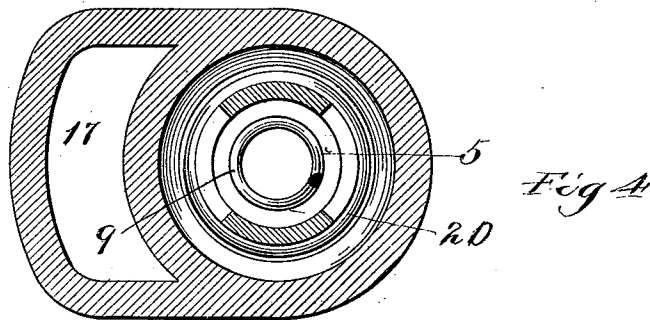

Fig. 4.

Witnesses
W. C. Collier
Martin A. Olsen.

Inventor
Paul Synnestvedt

UNITED STATES PATENT OFFICE.

PAUL SYNNESTVEDT, OF GLENVIEW, ILLINOIS, ASSIGNOR, BY MESNE ASSIGNMENTS, TO THE WESTINGHOUSE AIR BRAKE COMPANY, OF PENNSYLVANIA.

TRIPLE-VALVE MECHANISM.

SPECIFICATION forming part of Letters Patent No. 636,471, dated November 7, 1899.

Application filed October 29, 1896. Serial No. 610,422. (No model.)

To all whom it may concern:

Be it known that I, PAUL SYNNESTVEDT, a citizen of the United States, residing in Glenview, Cook county, Illinois, have invented certain new and useful Improvements in Triple-Valve Mechanism, of which the following, taken in connection with the accompanying drawings, is a specification.

My invention relates particularly to that part of the air-brake triple valve which is known as the "emergency" or "quick-action" portion; and it consists in certain novel mechanical features to be particularly pointed out in the claims and which I shall now proceed to describe in detail, reference being had to the accompanying drawings, in which—

Figure 1 represents in vertical cross-section a triple valve embodying my improvements. Fig. 2 represents an end view of the same. Fig. 3 is a plan section taken on the line 3 3 of Fig. 1, and Fig. 4 is a plan section taken on the line 4 4 of Fig. 1.

Referring now more particularly to Fig. 1, it will be seen that I have provided a body or casting 1, containing in its upper portion a chamber or casing, in which operates a slide-valve and its connected piston. These parts are substantially the same as the corresponding parts of other valves already well known in the art, and I will therefore omit any detailed description of them.

In the lower part of the body or casting 1 I provide a cylindrical chamber 2, containing a piston 3, which is operatively connected with an emergency-valve 4. The emergency-valve 4 is seated over an opening which leads directly to the brake-cylinder, as indicated on the drawings, and is arranged to operate within a cavity or chamber 5. Through the center of the piston 3 and its connected stem 6 is a hollow passage-way by which connection is established between the train-pipe air on the under side of the piston 3 and the chamber 5. This passage-way at a point just above the piston 3 is somewhat enlarged and contains in such enlarged portion a check-valve 7, seated on a bushing 8 and held against its seat by a spring 9.

For the purpose of holding the piston 3 and

its connected parts in their normal or released position (which is that shown in the drawings) I have provided beneath the piston 3 a spring 10, resting in a socket 11, which is supported in position by bridges 12, (see Fig. 3,) and against the under side of the bridges 12 I have arranged a screen or strainer 13, these parts, as well as the washer 14, being all held in place by the cap 15 and the four bolts 16. That part of the cylindrical chamber 2 which is above the piston 3 communicates with the main-piston cavity by means of the passage 17, and that part of the chamber 2 which is below the piston 3 connects directly with the train-pipe through the strainer or screen 13 by the passage 18. In the normal or release position of the parts, as shown in the drawings, there is a small passage 19, by which communication is established between the pressures on the upper and lower sides of the piston 3 and through which the application and release of the brakes in service application may be controlled without any movement of the piston 3. It is obvious then that in service applications the brakes are both applied and released by the passage of air through the small opening 19 without any operative effect on the quick-action parts. If now, however, it be desired to make an emergency application of the brakes and a sudden and extreme reduction of the pressure in the train-pipe be made, this reduction will take effect more rapidly below the piston 3 than it will above said piston, and this will cause the piston 3 to move downward, closing the passage 19 and pulling the emergency-valve 4 away from its seat, thus opening communication from the train-pipe through the hollow stem of the piston and the chamber 5 into the brake-cylinder, the check-valve 7 being raised from its seat by the rapid flow of the air. As soon as the pressure in the train-pipe is equalized with that in the cylinder the check-valve 7 will be returned to its seat by the spring 9, and as soon as the pressure above the piston 3 has reduced until it has become equal to the pressure beneath the piston the spring 10 will return the parts to the position shown,

allowing the emergency-valve 4 to seat and the passage 19 to open. If the pressure in the train-pipe should all escape—as, for example, by separation of the train—the emergency-piston 3 when moved to the bottom of its chamber will seat against the gasket 14, and the check-valve 7 being tight against its seat will prevent any escape of cylinder-pressure through the train-pipe.

As it is of course necessary that the pressure in the passage 17, which leads to the main-piston cavity, shall reduce with sufficient rapidity to permit the main piston and valve to move very promptly after or coincidentally with the opening of the emergency-valve, it follows that the air above the piston 3 must be permitted to escape rapidly. This can be accomplished by proper adjustment of the fit of the stem 6 of the piston within the bushing 2; but I prefer to make such fit a reasonably close one and then provide an additional small channel 21 in such position in the bushing 20 that it will establish communication between the chamber 2, chamber 5, and the brake-cylinder when the emergency-valve is fully open, and thus permit the ready escape of the air above the piston 3, the prompt backward movement of the main piston and slide-valve, and the rapid equalization of the auxiliary-reservoir and brake-cylinder pressures practically at the same instant that the emergency action is complete.

It is to be observed that between the emergency-valve 4 and its piston 3 I have provided a slight amount of slack. This accomplishes two things: First, it permits a slight movement of the piston 3 and the closure of the port 19 before the valve 4 is unseated, and, second, it prevents damage to the seat 4 by violent release of the brakes, any sudden upward movement of the piston 3 being stopped by impact of said piston against the bushing 20, the force of the shock against the valve 4 being cushioned by the spring 9. While this, as intimated, is the construction which I prefer, it is perfectly obvious that the valve 4 could be made integral with the stem of the piston 3, if desired, without departing from the spirit of my invention, and I have, in fact, experimented with valves so constructed.

Having thus described my invention, what I claim as new, and desire to secure by Letters Patent, is—

1. In triple-valve mechanism for automatic air-brakes, the combination with a main valve, a piston for operating the same and a cavity in which said piston works, of a train-pipe connection, an emergency-piston interposed between the pressures in said train-pipe connection and the train-pipe side of said main-piston cavity, a port leading into a brake-cylinder, an emergency-valve controlling said port operatively connected to said emergency-piston, a chamber in which said emergency-valve operates, and a hollow passage through said emergency-piston by which communica-

tion is established between the train-pipe connection and the emergency-valve chamber, substantially as described.

2. In triple-valve mechanism for automatic air-brakes, the combination with a main valve, a piston for operating the same and a cavity in which said piston works, of a casing having connections to a train-pipe and a brake-cylinder, an emergency-valve controlling the opening to said cylinder, a piston operatively connected with said emergency-valve and interposed between the pressures in the train-pipe side of said main-piston cavity and said train-pipe, a chamber in which said emergency-valve works and a passage through said piston connecting said emergency-valve chamber with the train-pipe, substantially as described.

3. An emergency-valve mechanism for automatic air-brakes comprising a casing, a train-pipe connection therefor, an emergency discharge-port, an emergency-valve controlling said port, a chamber in which said emergency-valve works, a piston operatively connected with said valve, and a chamber for said piston which is separated from said emergency-valve chamber by a fixed abutment: the said emergency-valve piston being exposed on one side to the pressure in the train-pipe side of the main-piston cavity and upon the other side to train-pipe pressure, whereby on a sudden reduction in the latter, the emergency-piston will be assisted by the outward movement of the air in the said train-pipe side of the main-piston cavity to unseat the emergency-valve.

4. In emergency-valve mechanism for automatic air-brakes, the combination of a casing having a train-pipe connection and an emergency discharge-port, an emergency-valve controlling said port, a chamber in which said emergency-valve works, a piston loosely connected to said emergency-valve, a passage through said piston establishing communication between said train-pipe connection and said emergency-valve chamber, a check-valve in said passage, and a spring interposed between said emergency-valve and said check-valve, substantially as described.

5. In emergency-valve mechanism for air-brake triple valves, the combination with the emergency-valve of a piston for operating the same loosely connected therewith, a passage through said piston, a check-valve seated in said passage and a spring interposed between said check-valve and said emergency-valve, substantially as described.

6. In emergency-valve mechanism for automatic air-brakes, the combination of a casing having a train-pipe connection and an emergency discharge-port, an emergency-valve controlling said port, a chamber in which said emergency-valve works, a piston loosely connected to said emergency-valve, a passage through said piston establishing communication between said train-pipe connection and said emergency-valve chamber, a

check-valve in said passage, a spring interposed between said emergency-valve and said check-valve, and a second spring bearing against said piston in direction to seat said emergency-valve and to hold said first-mentioned spring in compression and said piston in its uppermost position, substantially as described.

7. A triple-valve mechanism for automatic air-brakes comprising a casing, a train-pipe connection therefor, a main piston, a main-piston chamber, an emergency discharge-port, an emergency-valve controlling said port, a chamber in which said emergency-valve works, a piston operatively connected with said emergency-valve, a chamber for said piston, and an intermediate abutment separating said emergency-valve chamber and said piston-chamber: said emergency-piston being exposed on one side to the pressure in a chamber which has open communication with the train-pipe side of the main-piston chamber and on the other side to train-pipe pressure, and means whereby on a reduction of

the latter the emergency-valve will operate to vent both the train-pipe pressure and the pressure in the main-piston chamber through said emergency discharge-port.

8. An emergency-valve mechanism for automatic air-brakes comprising a casing, a train-pipe connection therefor, an emergency discharge-port for venting pressure in said train-pipe connection an emergency-valve controlling said port, a piston operatively connected with said emergency-valve, a main piston and chamber therefor, and a port arranged to establish communication between the main-piston chamber and the emergency-valve and constructed to be opened by the movement of said emergency-piston to permit the air from the main-piston chamber to escape past the emergency-valve whereby the application movement of the main piston is facilitated.

PAUL SYNNESTVEDT.

Witnesses:

JOHN CONWAY,
ROBERT GANFORD.