

Feb. 25, 1930.

J. C. ABEL

1,748,056

TANK DOME COVER AND LOCKING MEANS THEREFOR

Filed Feb. 4, 1928

2 Sheets-Sheet 2

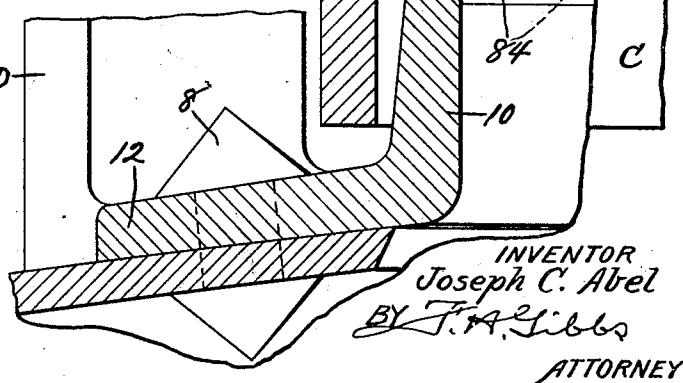
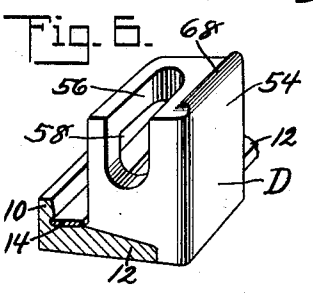
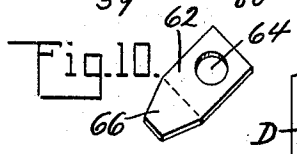
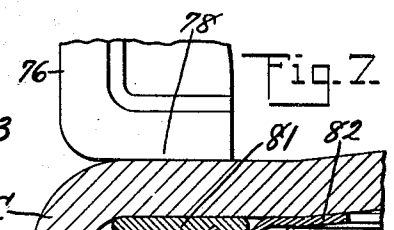
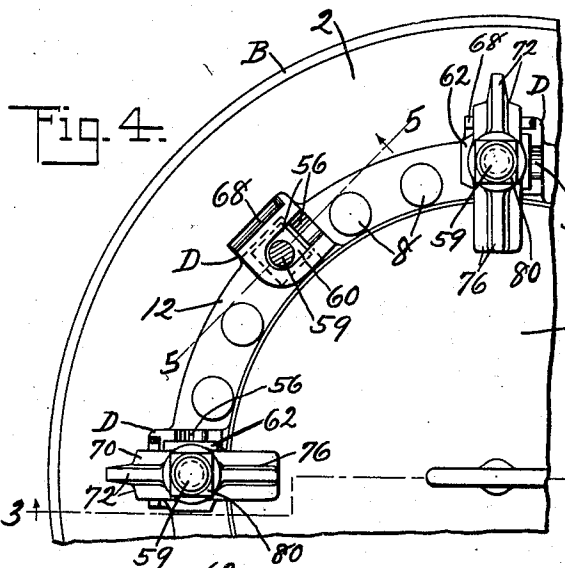
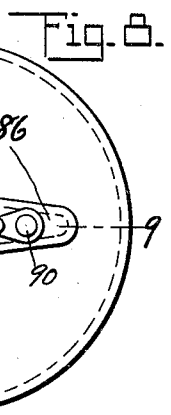
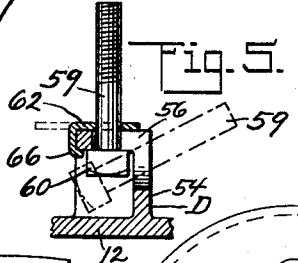
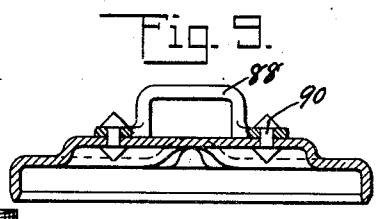
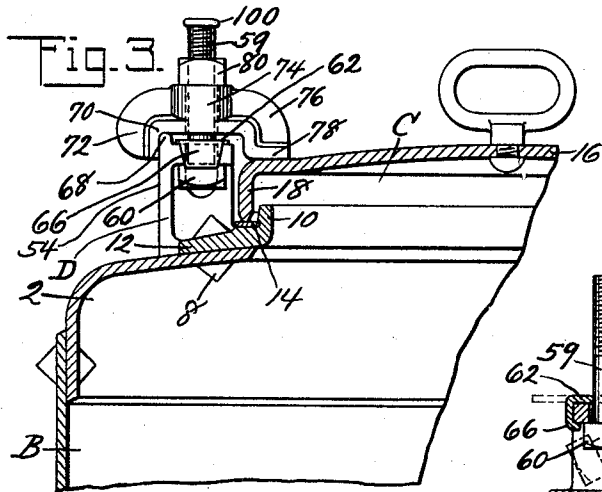

INVENTOR
Joseph C. Abel
BY J. A. Libbs
ATTORNEY

UNITED STATES PATENT OFFICE

JOSEPH C. ABEL, OF WESTWOOD, NEW JERSEY, ASSIGNOR TO AMERICAN CAR AND
FOUNDRY COMPANY, OF NEW YORK, N. Y., A CORPORATION OF NEW JERSEY

TANK-DOME COVER AND LOCKING MEANS THEREFOR

Application filed February 4, 1928. Serial No. 251,925.

Reference is had to the accompanying drawings which illustrate the preferred form of the invention, though it is to be understood that the invention is not limited to the exact details of construction shown and described, as it is obvious that various modifications thereof within the scope of the claims will occur to persons skilled in the art.

In the drawings:

10 Figure 1 is a central vertical section of a tank dome provided with a closure constructed in accordance with this invention, the view being taken on the line 1—1 of Fig. 2;

15 Fig. 2 is a partial plan view of the dome closure shown in Fig. 1, certain parts being broken away;

20 Fig. 3 is a fragmentary vertical section of a tank dome provided with a closure and having a modified form of securing means, the view being taken on the line 3—3 of Fig. 4;

Fig. 4 is a partial plan view of the construction shown in Fig. 3, certain parts being broken away;

25 Fig. 5 is a sectional view on the line 5—5 of Fig. 4;

Fig. 6 is a perspective view of one of the bolt lugs or clamp mounts shown in Figs. 3 and 4;

30 Fig. 7 is a fragmentary sectional view of a tank dome closure showing a modified form of sealing means for the cover of the dome;

Fig. 8 is a plan view of a modified form of dome cover;

35 Fig. 9 is a sectional view taken on the line 9—9 of Fig. 8; and

Fig. 10 is a perspective view of the retaining key used in conjunction with the bolt lug shown in Fig. 6.

40 This invention relates to an improved closure for car tank domes and to securing means therefor.

45 It is usual in the art to provide dome covers of cast metal having closure elements formed or cast therewith, but such cast metal dome covers are expensive to manufacture and are extremely heavy and inconvenient to handle.

50 It is one object of the present invention to provide a dome cover which is easy and inexpensive to manufacture and which is light and therefore easy to handle; such dome

covers being extremely strong and durable in usage.

Another object of the invention is to provide a cover for a car tank dome which is formed of pressed metal.

55 A further object of the invention is to provide means for securing pressed metal dome covers to car tank domes.

60 A still further object of the invention is to provide clamping means for pressed metal dome covers for car tank domes which when not in securing position are positively retained in such a manner as to prevent the extension of said clamping means over the dome ring whereby the dome cover may be easily and quickly placed in position on the dome ring.

65 Other objects and advantages of this invention will be apparent from the following description taken with the accompanying drawings in which, referring now to Figs. 1 and 2, a portion of a car tank is shown being designated as A. The car tank A is provided with a dome indicated generally at B which latter is provided with the dome head 2 having a manhole opening 4 formed therein about which a dome ring 6 is secured by rivets 8. The dome ring, as is customary, comprises the vertical annular portion 10 and the attaching base 12; the latter carrying a suitable packing 14 to form a seat for a dome cover indicated generally at C. The cover C is formed of metal pressed to the form shown clearly in the drawings, and includes the top portion 16 and a depending portion 18, the edge of which latter seats on the packing 14. As shown in Fig. 2, the top portion 16 is provided with a central outwardly pressed or convexed portion 20 to which is secured as by rivets 22, a handle 24. The top portion also includes an annular flat bearing surface 26 at the edge thereof with which the clamping elements 28 are adapted to contact to secure the cover C.

75 The attaching base 12 of the dome ring has cast therewith a plurality of bolt lugs which serve to mount the clamp elements as hereinafter described, each bolt lug comprising the spaced arms 30 connected by a back plate 32, the lugs being substantially U-shaped as

55

60

65

70

75

80

85

90

95

100

will be apparent from an inspection of Fig. 2. The clamps 28 heretofore mentioned are mounted on bolts 34 pivotally secured as by pins 36 in the spaced arms 30, and each clamp
 5 comprises a central apertured portion 38 and oppositely extending arms 40 and 42 respectively reinforced by the webs 44. The arm 40 is so formed as to rest upon the annular surface 26 of the cover, as clearly shown in
 10 Fig. 1, and the arm 42 is preferably formed larger than the arm 40 and is provided with a shoulder 46 adapted to seat on the back plate 32 when the clamp is in securing position. Nuts 48 are provided for securing the
 15 clamps in an obvious manner and the upper ends of the bolts are each provided with a head 49 to retain the nuts against loss. The arm 42 is also provided with a depending portion 47 for the purpose of engaging the
 20 outer surface of the back plate 32, thereby retaining the arms of the clamp 28 in radial alinement with the cover C when said clamp is being secured in position.

This invention contemplates means whereby
 25 by the bolts are retained in substantially a vertical position at all times to prevent them from falling inwardly to overlie the manhole opening, and to effect this result, the lower ends of the bolts are preferably of the form
 30 shown clearly in Fig. 1, each being provided with a lug 50 the outer surface of which is arranged adjacent the inner surface of the back plate 32 and is adapted to engage said surface to retain the bolts 34 in a substantially
 35 vertical position. It has been found desirable to provide means whereby the clamps 28, more particularly the arms 40 and 42 thereof, may be retained outside of the dome ring portion 10 when the dome cover
 40 C is removed from the dome. To accomplish this, the before-mentioned shoulder 46 of the arm 42 of the clamp elements is adapted to seat on the upper edge of either of the spaced arms 30. For purposes of illustration, one
 45 of the clamp elements has been designated as 51 in Figs. 1 and 2, and said clamp element is shown as being disengaged from the dome cover. When the clamp elements are swung to the position shown by the clamp
 50 element 51, the shoulders 46 of each clamp element rest upon either of the spaced arms 30 of the bolt lugs, and it will be apparent that the clamp elements are retained in this position, outside of the dome cover by means
 55 of the engagement of the shoulder 46 with the arm 30. To replace the clamp elements in clamping relation with the dome cover, it is necessary to elevate the clamp elements and then swing them laterally until the arm
 60 40 is positioned over and rests upon the annular surface 26 of the cover.

Referring to Figs. 3 and 4, which show modified forms of the invention, it can be seen that the dome ring, more particularly
 5 the attaching flange 12 thereof, is provided

with a plurality of bolt lugs which are modifications of the bolt lugs disclosed in Figs. 1 and 2. The bolt lugs in Figs. 3 and 4 are designated broadly at D and the construction thereof is more clearly indicated in Fig. 6.
 70 The bolt lugs are, in effect, clamp mounts and each comprises a substantially hollow block 54 having a recess 56 formed in the top and through one end thereof and an aperture 58 formed in the inner face of the
 75 block communicating with the recess 56 and permitting the insertion of a bolt 59 into the block to extend through the recess 56, as shown in Fig. 5. In this Fig. 5, the bolt is shown in broken lines as being inserted into
 80 the bolt lug and is shown in full lines in its final position; the bolt 58 being provided with a head 60 adapted to bear against the lower surface of the top of the block. For securing the bolt 58 against loss in the lug,
 85 a key 62 is provided, said key having an aperture 64 taking the bolt and being provided with a tapered end 66 adapted to be folded over the end of the block as shown in Fig. 5. The bolt lug is provided with a shoulder
 90 68 formed adjacent the upper edge thereof upon which the shoulder 70 of arm 72 of the clamp element 74 shown in Fig. 3 is adapted to rest. The clamp element 74 is provided with
 95 an arm 76 arranged opposite the arm 72 and provided with a bearing face 78 resting on the dome cover C. The clamp 74 is adapted to be retained in clamping engagement with the cover C by means of the nut 80 mounted on the
 100 bolt 54 in a manner similar to that heretofore described with reference to Figs. 1 and 2. The clamp element 74 may also be swung upon release of the nut 80 to a position similar to that heretofore described with reference to the clamp element 51, and when the
 105 clamp element 74 is so swung, it will be apparent that the shoulder 70 of the arm 72 of the clamp element will rest on the upper edge of the end of the bolt lug 54 and will be retained in this position, thereby permitting the easy and quick positioning of the
 110 cover C on the dome ring.

Fig. 7 discloses a modified form of sealing means, the same comprising a packing 81 retained in engagement with the inner surface
 115 of the dome cover C by means of a plate 82 which may be spot-welded to the cover C, the plate being punched as at 84 to define securing means for the packing 81, as will be apparent. In the type of sealing shown in Fig.
 120 7, the packing 80 is arranged over the upper end of the annular portion 10 of the dome ring.

Figs. 8 and 9 disclose modified forms of pressed metal dome covers in which the top of
 125 the dome cover is provided with corrugations or ribs 86 struck outwardly from the material of the cover itself. In the type of cover shown in Figs. 8 and 9, the handle 88 is secured as by rivets 90 to the corrugated por-
 130

tions, the latter serving to reinforce the cover in an obvious manner.

From the above description, it is believed that the operation and construction of the present invention will be fully apparent to those skilled in the art, but a brief résumé is here given.

With the dome cover secured to the dome, more particularly the dome ring, as shown in Fig. 1, when it is desired to remove the cover C, the nuts 48 on the bolts 34 are loosened until the clamps 28 may be elevated a sufficient distance that the shoulders 46 of said clamps will clear the back plate 32 whereupon the clamps 28 may be swung to the position shown by the clamp element 51 in Figs. 1 and 2. During the unscrewing of the nuts 48, if there be gas pressure in the tank above a degree of safety, it is apparent that the cover C will be lifted, thus permitting the gas to escape to the atmosphere, whereupon the cover will drop to its closed position by gravity and the clamps 28 may be swung and dropped to the position illustrated by the clamp 51 and the shoulder 46 will engage either of the spaced arms 30 and prevent swinging of the clamps over the opening defined by the annular portion 10 of the dome ring. It will be apparent that with the clamps positioned as illustrated by clamp 51 in Fig. 2, the dome cover C may be easily seated on the dome ring without interference by the clamps. The clamps 28 may then be each individually raised and swung on the bolts 34 to a position such that the arms 40 will engage the annular portion 26 and when in such position the nuts 48 may be tightened and the clamps thus firmly secured against the dome cover; said clamps being retained against displacement by means of the shoulder 46 in its engagement with the back plate 32.

Virtually the same operation prevails with regard to the construction shown in Figs. 3 and 4, with the exception that the bolts 54 shown in these figures are free to move vertically in the bolt lugs. However, the clamps 74 shown in Figs. 3 and 4 may be elevated and then swung on the bolts to a position such that the dome cover C may be freely removed from the dome ring, and the clamps retained in their free positions by reason of the fact that the shoulder 70 will engage one end of the bolt lug D. In this construction, it will be apparent that the weight of the bolts will serve to aid in retaining the clamps in their free positions; the bolts 54 being provided with the upset ends 100 for an obvious purpose.

What is claimed is:

1. A tank dome closure comprising a dome ring secured to the dome head, a plurality of clamp mounts secured to said ring, a pressed metal dome cover mounted on said ring, and clamps mounted in the clamp mounts and en-

gaging the cover to secure the latter, said clamps also engaging the mounts to retain said clamps in radial alinement with the cover.

2. A tank dome closure comprising a dome ring secured to the dome head, bolts lugs secured to the dome ring, bolts removably secured in the lugs, a dome cover mounted on the dome ring, clamps carried by the bolts and so formed as to engage said lugs to position said clamps in clamping position.

3. In a tank dome, a dome ring, a cover on said ring, and means for securing the cover to the dome comprising a plurality of clamp mounts secured to the dome ring, bolts carried by said mounts and normally retained in upright position, said mounts being provided with clamp engaging surfaces, and clamping elements pivotally supported on said bolts, each having a cover engaging arm and a positioning arm adapted to seat upon the before-mentioned clamp engaging surface to retain the clamping element against rotation.

4. In a tank dome, a dome ring, a cover on said ring, and securing means for the cover comprising clamp mounts secured to the dome ring each having a back plate, and clamping elements pivotally supported in the mounts and comprising a cover engaging arm and a positioning arm so formed as to be supported on the back plate whereby to retain said clamping elements in radial alinement with the cover.

5. In a tank dome, a closure therefor, and releasable means for securing the closure to the dome comprising a plurality of clamping elements, and clamp mounts for pivotally supporting said elements, each comprising a body portion having clamp engaging surfaces adapted respectively to restrain the clamping elements against movement when the latter are in clamping or free position.

6. In a tank dome, a closure therefor, and releasable means for securing the closure to the dome comprising a plurality of clamping elements each having a closure engaging arm and a positioning arm, and means for supporting said clamping elements comprising clamp mounts having clamp engaging surfaces with which the positioning arms contact whereby to restrain the clamping elements against rotation.

7. In a tank dome, a cover therefor, and means for securing said cover comprising clamp mounts secured to the dome and provided with clamp engaging surfaces, clamping elements pivotally supported in said mounts, each comprising a cover engaging arm and a positioning arm adapted to seat upon and overlap the clamp engaging surfaces whereby to restrain the element against displacement when the latter is in clamping position or in disengaged position.

8. In combination with a tank dome and

its cover, means for securing the cover comprising a plurality of clamp mounts each including spaced arms and a back plate connecting said arms, bolts mounted in said arms, means at the lower end of said bolts for retaining them in substantially vertical position, and clamping elements mounted on said bolts having oppositely arranged arms, one thereof adapted to engage the cover and the other being so formed as to overlie the before-mentioned back plate to retain the clamping element in radial alinement with the cover and also to overlie the spaced arms when the clamping element is in free position whereby to hold the latter outside of the cover area.

9. In a tank dome closure, a cover, clamping elements for the cover having oppositely extending arms, and means for supporting said clamping elements whereby the same are restrained against rotation comprising clamp mounts in which the clamping elements are mounted, said mounts being provided with clamp engaging surfaces upon which one of the arms of the clamping elements is adapted to rest and over which the said elements overlie.

10. In a tank dome closure comprising a ring, a cover mounted on the ring, a plurality of bolt lugs secured to the ring, bolts pivotally mounted in the lugs, a clamping element carried by each bolt, said clamping elements having oppositely disposed arms, one thereof being adapted to engage the cover and the other being adapted to rest upon the clamp lug to restrain said clamp element against rotation.

11. In a tank dome, a closure therefor, and releasable means for securing the closure to the dome comprising a plurality of clamping elements each having oppositely extending closure engaging arms and positioning arms respectively, means for supporting said clamping elements comprising clamp means having clamp engaging surfaces with which the positioning arms contact whereby to restrain the clamping elements against rotation, and bolts loosely mounted in the clamp mounts and on which said clamping elements are mounted.

12. In a tank dome, a dome ring, a dome cover, and means for securing the cover to the ring comprising clamp supporting bolts mounted adjacent the dome ring, clamping elements carried by the bolts and rotatable horizontally to be arranged radially of the cover, means securing said clamping elements in such radial position to secure the cover, and means in which the clamp supporting bolts are mounted for restraining the clamping elements against horizontal shifting.

13. In a tank dome, a dome ring, a dome cover, and means for securing the cover to the ring comprising clamp mounts secured to the dome ring, clamp supporting elements removably positioned in the mounts, double-

ended clamping elements loosely arranged on the supporting elements and rotatable horizontally to overlie the cover and clamp means, and means for securing the clamp elements when in said overlying position to secure the cover.

14. In a tank dome, a dome ring, a dome cover, and means for securing a cover to said ring comprising double-ended clamping elements rotatable horizontally to be arranged radially of the cover with one end overlying said cover, means with which the opposite ends of said elements are engaged to restrain said elements against horizontal shifting, and means for securing the clamping elements in such radial position against vertical shifting.

In witness whereof I have hereunto set my hand.

JOSEPH C. ABEL.

70
75
80
85
90
95
100
105
110
115
120
125
130