

Oct. 13, 1931.

J. BEYER

1,827,454

SECURING MEANS FOR CAR TANK DOME CLOSURES

Filed April 4, 1929

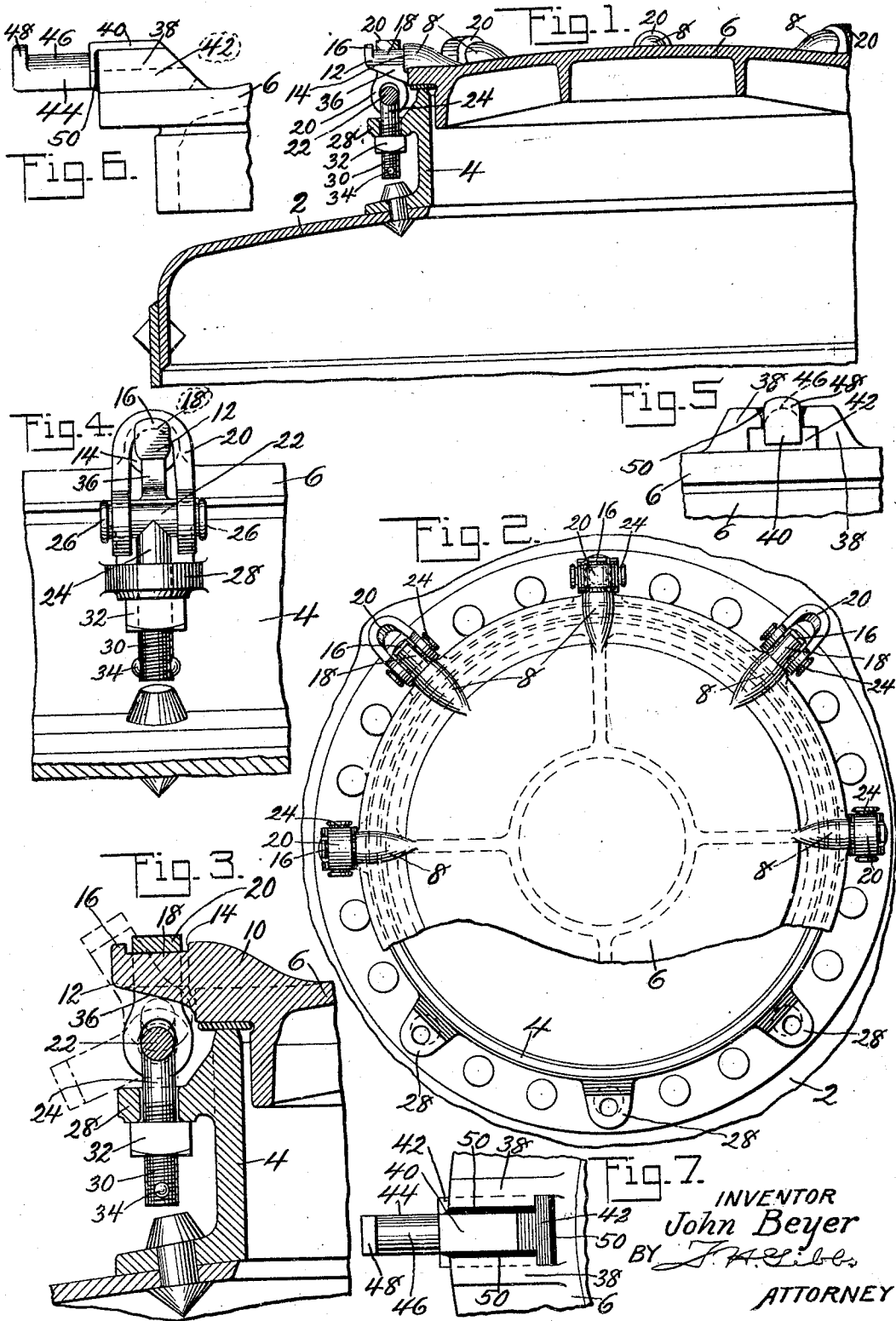

INVENTOR  
John Beyer  
BY *J. A. Seibel*  
ATTORNEY

# UNITED STATES PATENT OFFICE

JOHN BEYER, OF BAYONNE, NEW JERSEY, ASSIGNOR TO AMERICAN CAR AND FOUNDRY COMPANY, OF NEW YORK, N. Y., A CORPORATION OF NEW JERSEY

## SECURING MEANS FOR CAR TANK DOME CLOSURES

Application filed April 4, 1929. Serial No. 352,422.

This invention relates generally to car tanks and has particular reference to securing means for car tank dome closures.

One object of the present invention is the provision of means for preventing the blowing off of dome covers upon release of the securing means therefor.

Another object of the invention is the provision of dome cover securing means which, even though released, prevents the removal of the dome cover from the dome while there is excess gas pressure within the tank.

A further object of the invention is the provision of a dome cover securing means which is easy and inexpensive to manufacture and strong and durable in operation.

Other objects and advantages of this invention will be apparent from the following description taken in conjunction with the accompanying drawings in which:

Figure 1 is a partial vertical section of a car tank dome showing the present invention applied thereto;

Fig. 2 is a top plan view of a car tank dome, certain parts being broken away;

Fig. 3 is an enlarged detail sectional view of a portion of a tank dome and dome cover showing in full lines the securing means in securing position and in broken lines the securing means in their released position;

Fig. 4 is a front elevation of one of the securing means in cover securing position;

Fig. 5 is an end view of a modified form of the invention;

Fig. 6 is a side elevation of the form shown in Fig. 5; and

Fig. 7 is a top plan view of the part shown in Fig. 5.

Referring now more particularly to the drawings in which similar characters of reference designate similar parts in the several views, the said drawings disclose a portion of a tank dome having a head 2, a dome ring 4 and a dome cover 6 seated on the dome ring.

In the form of the invention shown in Figs. 1 to 4 inclusive, the dome cover 6 is provided with a plurality of integral radially extending projections or lugs, indicated generally at 8, which are substantially equidistantly spaced, as clearly shown in Fig. 2, and each

of which comprises a main body portion 10 (see Fig. 3) and a reduced forward portion 12 defining a shoulder 14. The extreme end of each projection is provided with an upwardly extending flange 16; the reduced end 12, with the shoulder 14 and the flange 16, outlining a seat 18 for the reception of a U-shaped yoke 20, the ends of which are apertured to pivotally engage the head 22 of a yoke carrier 24 in the form of a T-bolt. For preventing disengagement of the yoke with the carrier 24, the ends of the head 22 are preferably upset as shown at 26. The yoke carrier 24 is arranged through and is longitudinally movable in an apertured lug 28 formed integral with the dome ring 4 and extending outwardly therefrom; there being, of course, a lug for each of the projections 8. The yoke carrier is threaded at its lower end, as shown at 30, to receive an adjusting nut 32 which is adapted to bear against the lower surface of the lug 28. To prevent accidental loss of the nut 32, the yoke carrier at its lower end is provided with suitable retaining means, such as the soft head rivet 34. To provide additional strength, the end of the projection is provided with a stiffening web 36 which is clearly shown in the drawings as merging with the edge of the cover.

Figs. 5, 6 and 7 disclose details of a modified form of the invention, and the dome cover in this form is provided with a plurality of pairs of guides 38 which receive independent lugs 40, the same each comprising a T-shaped base 42 adapted to be inserted between the guides, which latter, in the instance shown, define inverted T-shaped guideways, and the projection 44 comprising the yoke seat 46 and each having an end flange 48 similar to the flange 16 hereinbefore described. For securing the projections, the latter are preferably welded in any suitable manner and by any preferred method of welding to the guides, as shown at 50. The form of invention shown in Figs. 5, 6 and 7 has an advantage in that should any of the projections be broken they may be removed by burning at the welded joints and a replacement made, as will be apparent.

In use, as before mentioned, the dome ring

is provided with lugs corresponding to the number of projections 8 each having a yoke carrier. The dome cover is applied to the dome ring 4 and the yokes 20 are then engaged over the projections 8 and more particularly are positioned in the seats 18, whereupon the nuts 32 may be screwed home to tighten the yokes in their engagement with the projections 8. When it is desired to remove the cover 6, the nuts 32 are backed off on the yoke carrier, and it will be apparent that should there be excessive gas pressure within the tank, the dome cover 6, when the nuts 32 are loosened, will be urged upwardly by the excess gas pressure thereby opening the interior of the tank to the atmosphere to vent the gas from the tank. Because of this upward movement of the cover 6, it will be apparent that the yokes will be retained in engagement with the projections and they cannot be readily removed from their engagement because of the flanges 16 at the ends of the projections. When the gas pressure has been reduced to a safety point, the dome cover 6 will, of course, reseal on the dome ring whereupon the yokes may be removed from their engagement with the projections and the cover then removed.

From the above description, it is believed that the construction of the device of the present invention will be fully apparent to those skilled in the art when taken in conjunction with the accompanying drawings, but it is to be understood that the latter are for illustrative purposes only and that various changes in the form and proportions of the scheme outlined herein may be made within the scope of the appended claims without departing from the spirit of the invention.

40 What is claimed is:

1. In a container, a cover therefor, a cover support, and means for securing the cover to the support comprising projections extending radially of the cover, bolts connected with the cover support and longitudinally movable relative thereto, and yokes pivotally secured to the bolts and engaging the projections.

2. In a tank, a closure therefor having radial projections, and means for securing the closure to the tank comprising yokes detachably engaging the projections, and yoke carriers connected to the tank and movable with respect thereto to place the yokes in tension on said projections.

3. In a tank dome, a dome ring, a cover seated on the dome ring and provided with radial projections having depressed seats at their ends, and cover securing means comprising yoke carriers connected with the dome ring and movable relative thereto, and yokes pivotally secured to the carriers and engaged in the before mentioned depressed seats.

65 4. In a tank dome having a manhole open-

ing, a dome ring surrounding said opening, a plurality of apertured lugs extending outwardly from the ring, longitudinally movable yoke carriers mounted in the lugs, a dome cover having radial projections provided with depressed areas defining seats having an outer flange, and yokes pivotally secured to the yoke carriers and normally engaged in said seats and retained against endwise shifting by said outer flange.

5. In a car tank dome, a dome ring, a cover seated thereon and provided with radial projections, apertured lugs on the dome ring, yoke carriers mounted in the lugs and longitudinally movable with respect thereto, yokes pivotally secured to the carriers above the lugs, and nuts on said carriers for adjustment thereon to firmly engage the yokes with the projections.

6. In a car tank dome, a dome ring, a cover normally seated thereon and provided with radial projections, and means for securing the cover to the ring comprising U-shaped yokes movable vertically in an arc to engage over the projections, longitudinally shiftable yoke carriers connected to the dome ring and to which the yokes are pivoted, and means carried by the yoke carriers to tighten the yokes in their engagement with the projections.

7. In combination with a tank dome and a cover therefor, means for securing the cover comprising projections formed with the cover, yoke carriers connected with the dome, and yokes connected to said carriers and engageable over the projections and adjustable downwardly with respect to the dome and cover to tightly engage the projections.

8. In combination with a tank dome and a cover therefor, means for securing the cover comprising projections formed with the cover, longitudinally shiftable T-bolts loosely connected to the dome, yokes pivotally connected to the heads of said bolts and engageable over the projections, and means for adjusting the bolts to secure the yokes to the projections.

9. In combination with a tank dome and a cover therefor, means for securing the cover comprising projections extending radially of the cover and provided with depressed areas, T-shaped bolts connected to the dome and longitudinally adjustable with respect thereto, said bolts having their heads uppermost, yokes pivotally secured to the heads of said bolts and adapted to be engaged with and disengaged from the projections on the cover, and means on the bolts for adjusting the latter to secure the yokes to the projections.

10. In combination with a tank dome and a cover therefor, means for securing the cover comprising apertured lugs on the dome, T-shaped bolts in the apertures in said lugs, yokes pivotally secured to the heads of said bolts, the heads of said bolts being arranged

above the apertured lugs, projections extending radially from the cover and with which said yokes engage, and adjustable means carried by the bolts for adjusting the latter to  
5 cause said yokes to tightly engage the projections, said adjustable means being so constructed and arranged that they engage with lower surfaces of said lugs to retain the T-shaped bolts and yokes in cover securing position.  
10

11. In a tank dome, a dome ring having apertured horizontal lugs extending therefrom, a cover seated on the ring and provided with radial projections, longitudinally shift-  
15 able T-shaped bolts arranged in the apertures in said horizontal lugs, a yoke pivotally secured to each of said bolts at the heads thereof and being so arranged as to swing vertically in an arc to be engaged with or disengaged from the said projections, and means  
20 carried by said bolts below the horizontal lugs for securing the yokes in engagement with the cover projections.

In witness whereof I have hereunto set  
25 my hand.

JOHN BEYER.

30

35

40

45

50

55

60

65