

LOCOMOTIVE CONTROL



GP35 STATIC CONTROL

THIS ITEM IS BOTH
PHYSICAL (ON SITE)
AND
DIGITAL (ONLINE)!

[CLICK HERE TO
DOWNLOAD A PDF.](#)



LOCOMOTIVE CONTROL



GP35 STATIC CONTROL

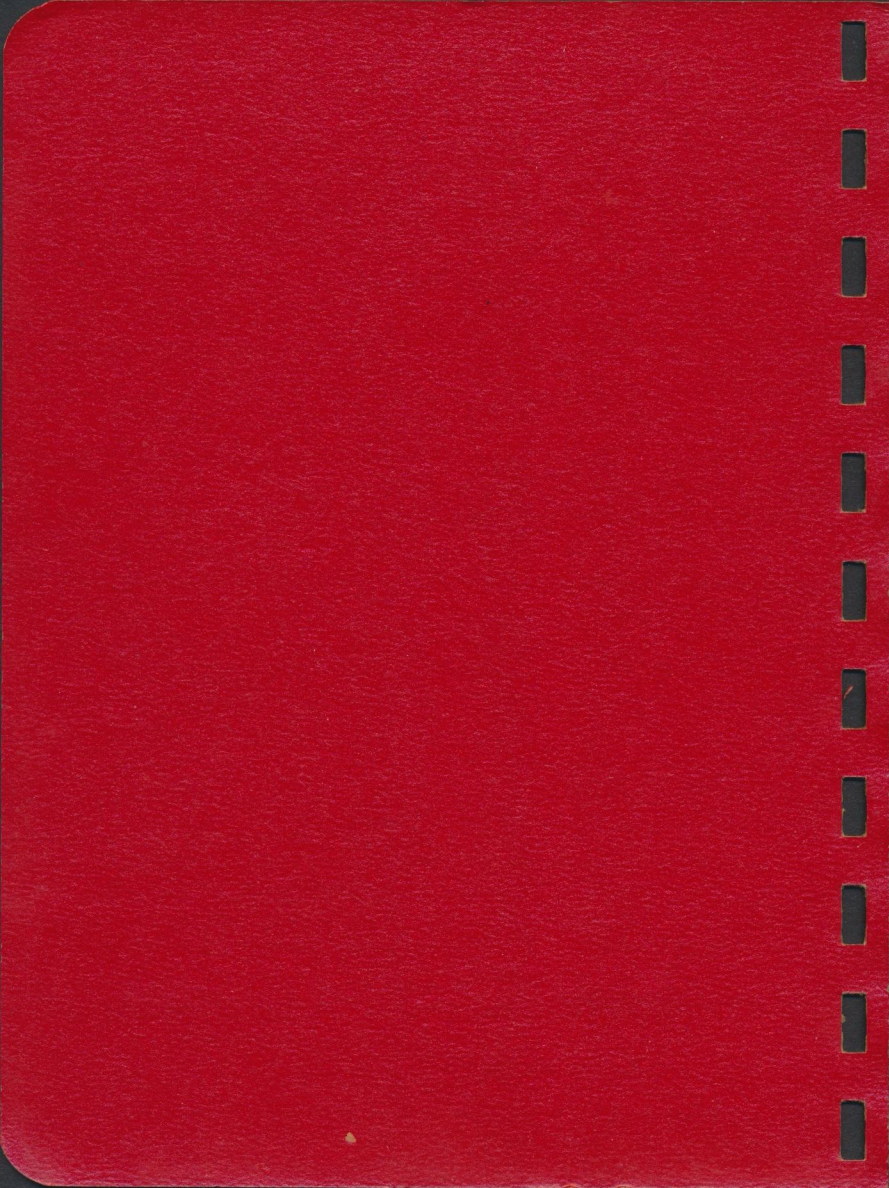

LOCOMOTIVE CONTROL HANDBOOK

GP35 STATIC CONTROL

*Property of
National Museum of Transportation
Library*

March, 1964

SERVICE DEPARTMENT
ELECTRO-MOTIVE DIVISION
GENERAL MOTORS CORPORATION
LA GRANGE, ILLINOIS, U.S.A.



CAUTION

The diagrams used in this handbook are simplified and are presented only as a guide and as an aid in explaining the GP35 control system. The circuits and values shown do not necessarily agree with the wiring of specific locomotives. Always consult the applicable locomotive wiring diagrams when working with the control system.

Although trouble shooting and adjustment procedures are included in the handbook, they are intended only as a guide. Do not attempt control system adjustment using only the information presented here. The adjustment procedures appearing on the schematic wiring diagram covering a specific locomotive take precedence over information presented here.

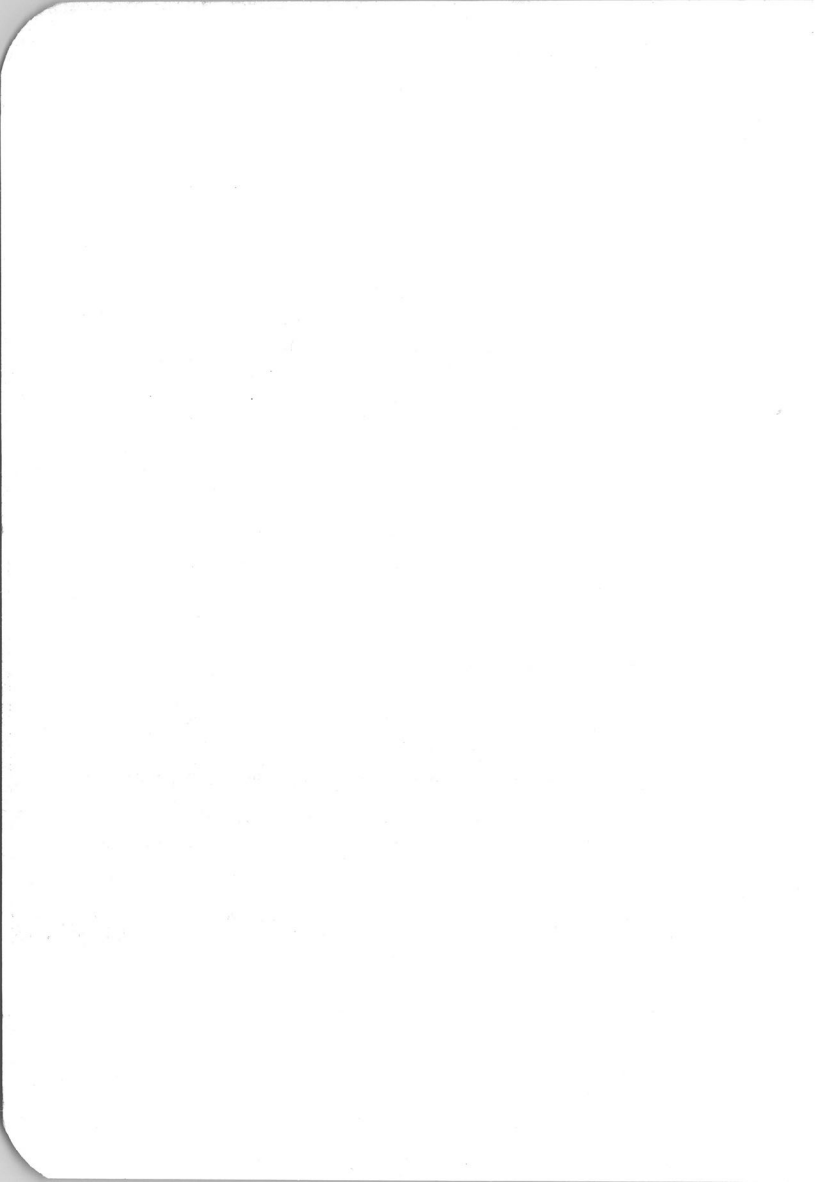

INTRODUCTION

The purpose of this handbook is to describe the GP35 locomotive power control system and to serve as a guide to those who wish to familiarize themselves with the system.

The major differences between the GP35 power control system and the systems of models earlier than the GP30 lie in:

1. Application and control of main generator battery field excitation.
2. Control of transition from series-parallel to parallel, and control of the steps and percentage of motor field shunt.
3. Application and control of dynamic brakes.
4. Control of wheel slip while under power and while in dynamic braking.

The major differences between the GP35 power control system and the GP30 power control system lie in the number of steps of motor field shunting employed and in the use of a shunt limiting circuit to control the percentage of motor field shunt when fields are hot. This control improves commutation and increases traction motor brush life.

The handbook is divided into four sections:

Section 1 covers main generator battery field excitation.

Section 2 covers transition control.

INTRODUCTION

Section 3 covers dynamic brake and wheel slide control.

Section 4 offers information that may be used when checking or trouble shooting the control system.

The text follows in a step-by-step manner the actual sequence of control operation. It is supplemented by graphs and schematic wiring diagrams that appear adjacent to related text.

SECTION 1

GP35 EXCITATION SYSTEM

Fig. 1-1 depicts the GP35 excitation and performance control system. It should be understood that while the performance control system functions within adhesion considerations to allow compatible operation in mixed consists, the governor is still the primary engine power output controlling device.

As indicated in Fig. 1-1, three phase alternating current for excitation of the D32 generator battery field is taken from the D14 alternator. Use of alternator power provides an excitation range greater than that available in systems that use auxiliary generator power and commutator type load regulators. When auxiliary generator power is used for excitation under extreme conditions of

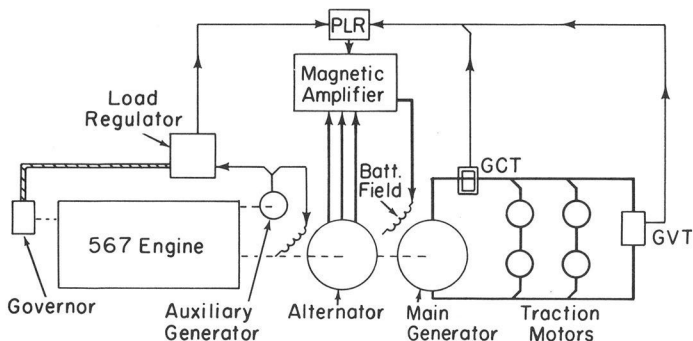

12082

Fig. 1-1 — Excitation System Block Diagram

EXCITATION SYSTEM

temperature, the excitation range is from zero to 45 amperes. Under like conditions of temperature the GP35 (and the GP30) excitation system, which uses D14 power and a wirewound rheostat to effect load regulation, has a range of from 1.5 to 70 amperes. The extended range is made possible by the use of 195 volts from the D14 alternator as compared to 74 volts from the auxiliary generator.

D14 alternator current is fed to and rectified by a magnetic amplifier, where it is controlled by a polarized relay PLR and a low power load regulator that is under the influence of the engine governor. The rectified and controlled current is then fed to the D32 generator battery field.

EXCITATION SYSTEM

The load regulator is a 100 ohm 100 watt wirewound tapered rheostat that has the function of controlling the output of the magnetic amplifier rather than limiting the battery field current directly as does the commutator type load regulator. The regulator is driven by a vane motor similar to that which drives the commutator type.

A signal proportional to main generator voltage is taken from the generator voltage transducer GVT. This signal is added to a similar signal, proportional to main generator current, which is derived from the generator current transducer GCT. The sum of these two signals is then used to control the output of the magnetic amplifier through a polarized relay PLR. The functions of each of these devices are described in the following text and diagrams.

Fig. 1-2 shows one of the three identical reactors which, together with a 3-phase silicon rectifier, make up the magnetic amplifier. It is the function of the three reactors to control or limit the flow of 3-phase alternating current from the D14 alternator to the generator battery field. The silicon rectifier, in addition to rectifying this D14 current, insures that current always flows through the reactor load windings in a direction from 1 to 2 and from 3 to 4.

Current flowing through any of the remaining three windings in a direction from 7 to 8, 9 to 10, or 11 to 12 increases the flow of current in the 1-2 and 3-4 load windings. Conversely, any flow of current in these windings from 8 to 7, 10 to 9, or 12 to 11 decreases the flow of current in the load windings.

EXCITATION SYSTEM

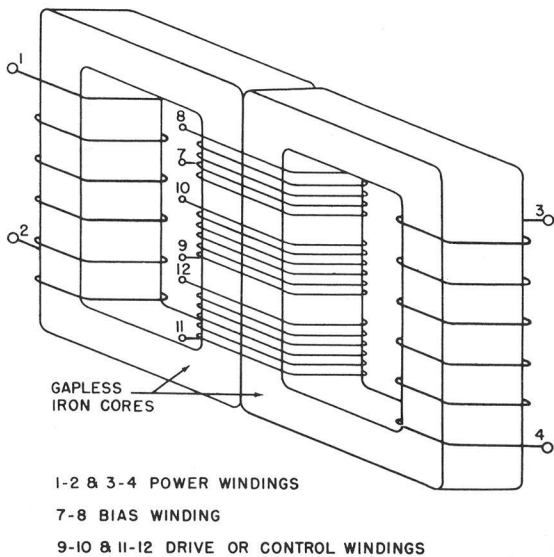

10904

Fig. 1-2 — Battery Field Excitation Reactor

EXCITATION SYSTEM

Two types of transducer reactors used on the GP35 locomotive are shown in Fig. 1-3.

Reactors of the type shown in Fig. 1-3(A) are used to detect main generator current. The flow of an alternating current in the AC coils of current transducer GCT is proportional to the flow of main generator current in the bus passing within the reactor core. This type of transducer is also used as a motor field current transducer. Other applications of the current transducer are the detection of current in the dynamic braking grids when the locomotive is equipped with extended range dynamic brakes, and detection of the braking signal in the field loop when the locomotive is so equipped.

Two reactors of the type shown in Fig. 1-3(B) are used to make up the voltage transducer GVT. The flow of an alternating current in the AC coils of the voltage transducer reactors, 3-4, is proportional to the flow of direct current in coils 1-2. Thus if the current in the 1-2 coils is proportional to the main generator voltage, the flow of AC current in the 3-4 coils is proportional to the main generator voltage.

EXCITATION SYSTEM

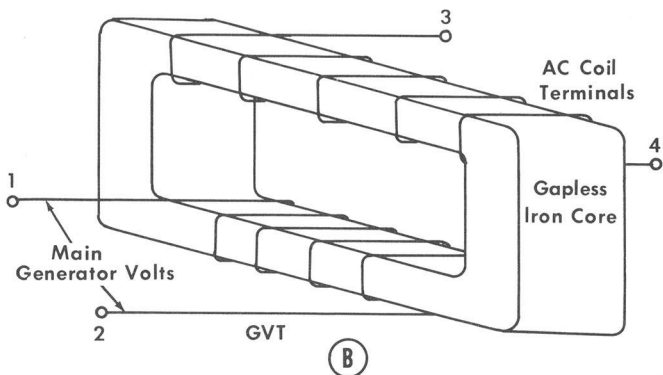
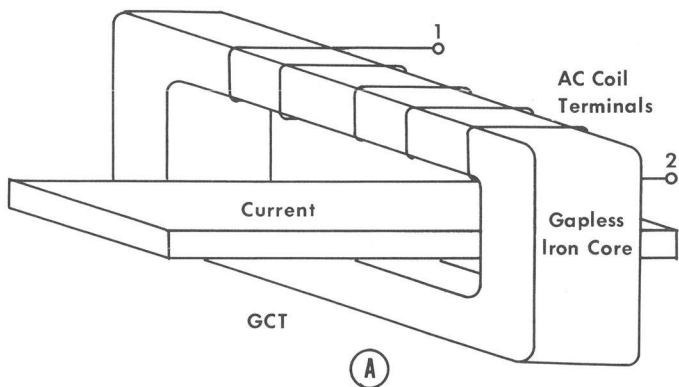

12083

Fig. 1-3 — Current And Voltage Transducer Reactors

EXCITATION SYSTEM

Fig. 1-4 shows the results of using rectified D14 current for battery field excitation without the benefit of a controlling device. As can be seen from the graph, the current received from the D14 alternator would be greater than the capacity of the battery field. Also, since there is no control over the level of excitation, engine load control and train handling would be difficult.

EXCITATION SYSTEM

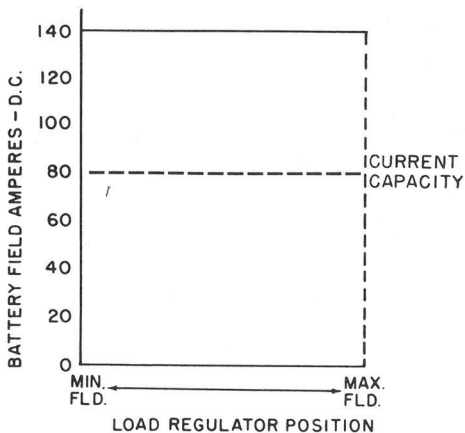
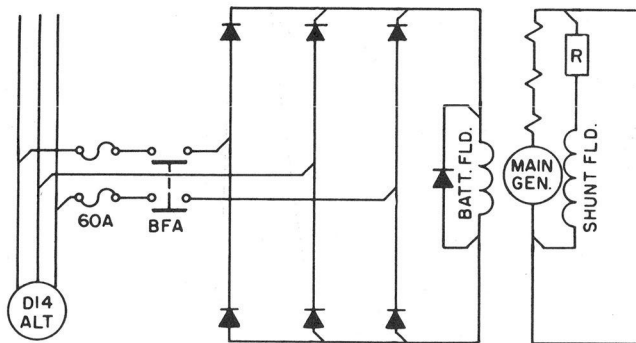

12084

**Fig. 1-4 — D14 Current Used To Excite
Battery Field Without Reactors**

Fig. 1-5 shows the drop in battery field current caused by the addition of the load windings of three magnetic reactors, FM1, FM2, and FM3 to the circuit shown in Fig. 1-4. The addition of the load windings results in a constant current of approximately 50 amperes (Run 8). While this current is within the capacity of the battery field, there still is no control provided. Note that the current always passes through the reactor windings from odd to even or from 1 to 2 and from 3 to 4. This is a key to the operation of magnetic amplifiers.

EXCITATION SYSTEM

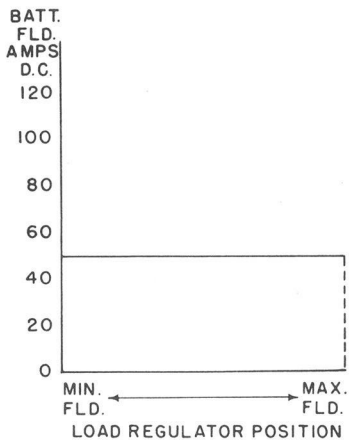
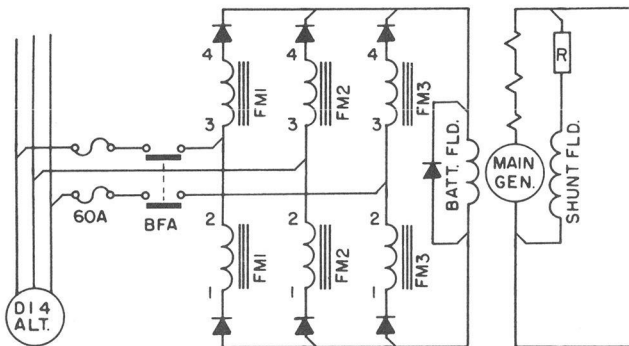

12085

Fig. 1-5 — The Effect Of Using
Reactor Load Windings Only

Fig. 1-6 shows part of the circuitry required to control the flow of minimum battery field current. This first step of control is the addition of bias current to the reactors. A 200 turn control winding on each reactor is used for this purpose. The winding is excited with 135-160 milliamperes of control current. This current flows from 8 to 7 or even to odd in this winding. Since current in this direction is in opposition to that flowing in the load windings 1 to 2 and 3 to 4, it opposes the flow of current in the load windings. This increases the impedance of the reactors and results in a flow of 1.5 amperes or less in the battery field. This is not sufficient to properly excite the main generator and pull a train.

EXCITATION SYSTEM

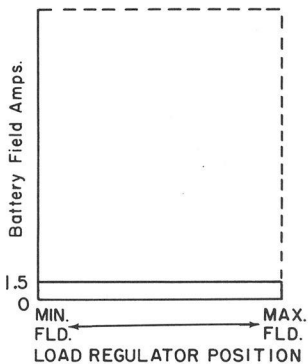
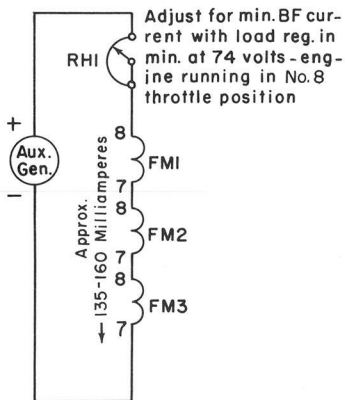
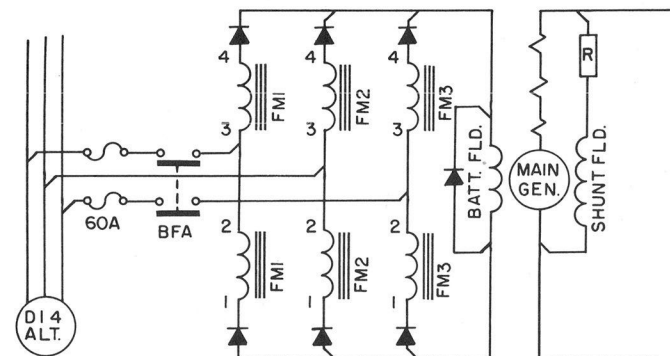

1 2086

Fig. 1-6 — The Effect Of Using Reactor Bias Windings

EXCITATION SYSTEM

In Fig. 1-7 complete control of the battery field current is accomplished. The load regulator is used to excite a 500 turn control winding on each reactor in a direction from 11 to 12. This current is in opposition to that flowing in the 8 to 7 windings and results in lowering the impedance of the reactors FM1, FM2, and FM3. When RH2 is adjusted to excite the 11-12 windings with 60 to 70 milliamperes, proper battery field amperage will result with 80 volts across the battery field.

The governor will now have complete control of the engine load, and proper train handling is possible.

EXCITATION SYSTEM

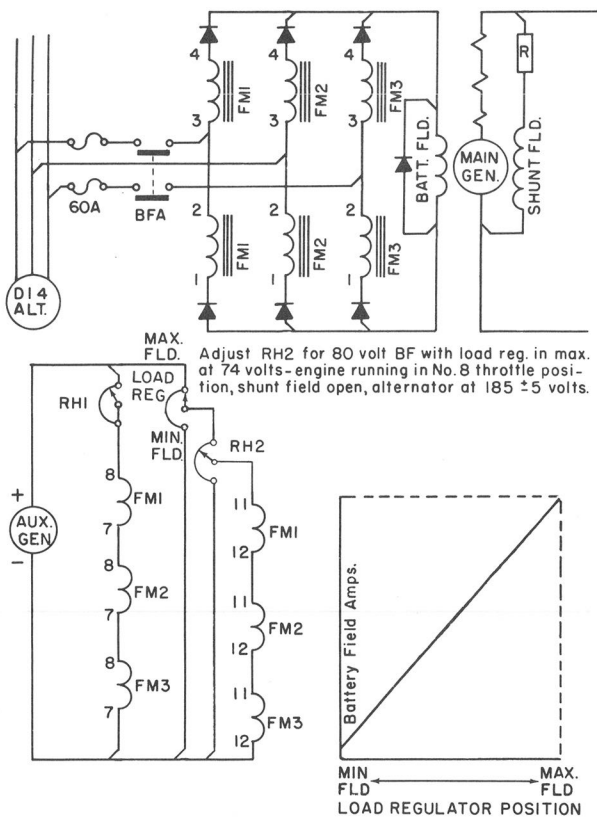

12087

Fig. 1-7 — The Effect Of Adding Reactor Drive Or Control Windings

EXCITATION SYSTEM

The characteristics of the excitation system described up to this point are similar to those of the commutator type load regulator, except with an increase in range. However, the GP35 control system includes circuitry to accomplish the following:

1. In series-parallel motor connection it compensates for fluctuations in horsepower due to variations in quality and condition of fuel, ambient temperature and air pressure, and metering of fuel to the injectors.
2. Regulates to provide optimum power at train speeds between approximately 12 and 18 miles per hour to allow continuous operation in that speed range.
3. Regulates power out of the main generator at speeds below 12 miles per hour, allowing the GP35 to work at optimum power and speed for extended periods.

EXCITATION SYSTEM

The characteristic of the GP35 control system that allows it to compensate for fluctuations in horsepower and to regulate horsepower overrides the engine governor. The load regulator will rest in maximum field position whenever the compensating or regulating characteristic is in effect. This characteristic is maintained by use of a main generator voltage transducer GVT, a main generator current transducer GCT, two 4 to 1 transformers T3 and T4, two rectifier bridges CR20 and CR21, two rheostats RH4 and RH7, and a performance control relay PLR.

Fig. 1-8 shows how the main generator transducer GCT is used to supply a signal proportional to main generator current.

The cores of reactor GCT, which are gapless, are firmly clamped around the main generator bus. Thus the flux density or degree of saturation of these cores is proportional to the level of current in the main generator bus. It follows then that the level of AC current which will pass through coils wound on these cores will also be proportional to the generator current. This current is passed through the primary winding X1-X2 of a transformer, T3. If a short circuit is placed across the secondary, H1-H4, the current in the primary will be proportional to the generator current as shown in the graph on Fig. 1-8.

EXCITATION SYSTEM

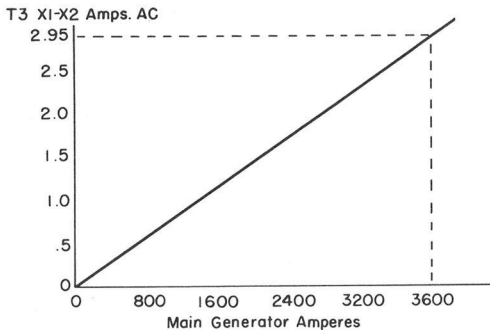
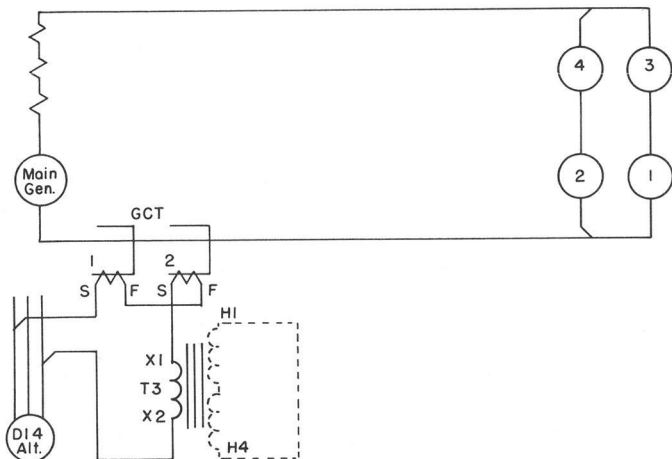

12088

Fig. 1-8 — Current Feedback System

EXCITATION SYSTEM

In Fig. 1-9 the secondary of the transformer T3 is added to the circuit shown in Fig. 1-8. As a step toward making the signal easier to use, the T3 secondary current is rectified through the use of CR3 and is loaded on RH7.

Due to the 1 to 4 transformer ratio, the resultant direct current signal is only $1/4$ the value of the AC current in the primary circuit (X1 to X2) in Fig. 1-8. This DC signal is proportional to main generator current and of a value suitable for control purposes. The following text and illustrations indicate how control is accomplished.

EXCITATION SYSTEM

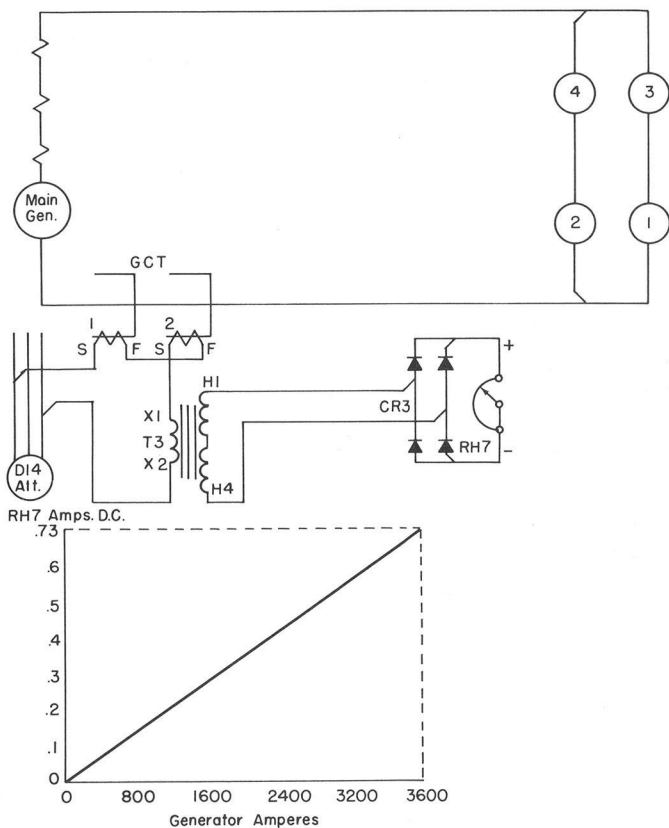

12089

Fig. 1-9 — Current Feedback System

EXCITATION SYSTEM

In the circuit shown in Fig. 1-10 there is a usable signal in the DC voltage drop across the loading rheostat RH7. If the proper value of resistance is chosen for this rheostat, it can be adjusted to give a 74 volt DC signal at 3,600 amperes on the main generator. The main generator can be short circuited for this setting merely by mounting a 2000 ampere meter shunt to the right of the load shunt panel on a bracket provided.

EXCITATION SYSTEM

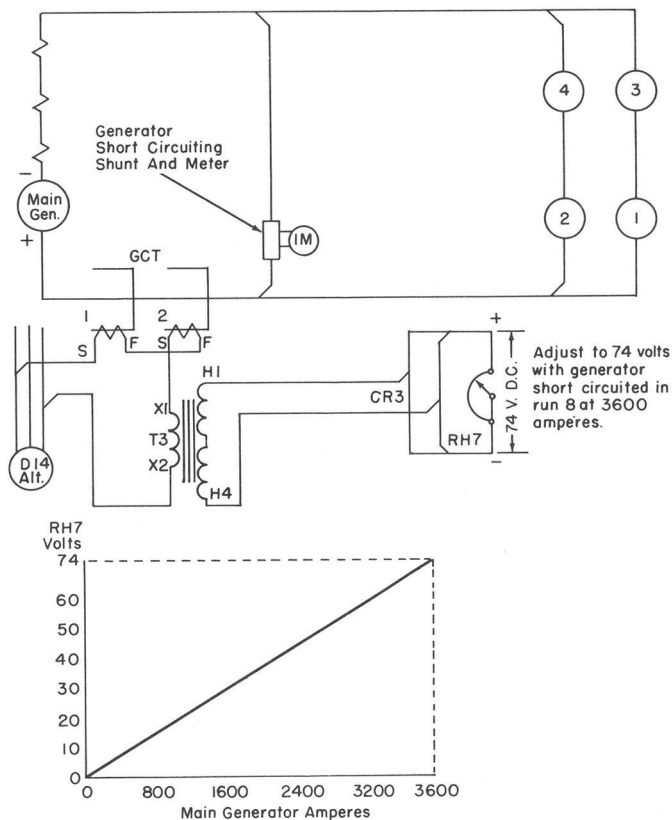

12090

Fig. 1-10 — Current Feedback System

In Fig. 1-11 the means have been added to give a DC voltage signal proportional to the main generator voltage in a manner very similar to that used to get the generator current signal.

To obtain the voltage signal a current proportional to generator volts is passed through coils wound on the cores of transductor reactor GVT. As with the GCT, AC current in the secondary coils on these cores will be proportional to the main generator voltage. This current is transformed and rectified and passed through RH4. If a 1950 volt source were available, RH4 could be adjusted to give us a 74 volt DC signal. In practice the RH4 setting can be obtained with an MG set on short circuited main generator after RH7 is adjusted. The generator voltage and amperage values must then fall on the power limit line. (See graph in lower portion of Fig. 1-12 and refer to Fig. 4-6.)

EXCITATION SYSTEM

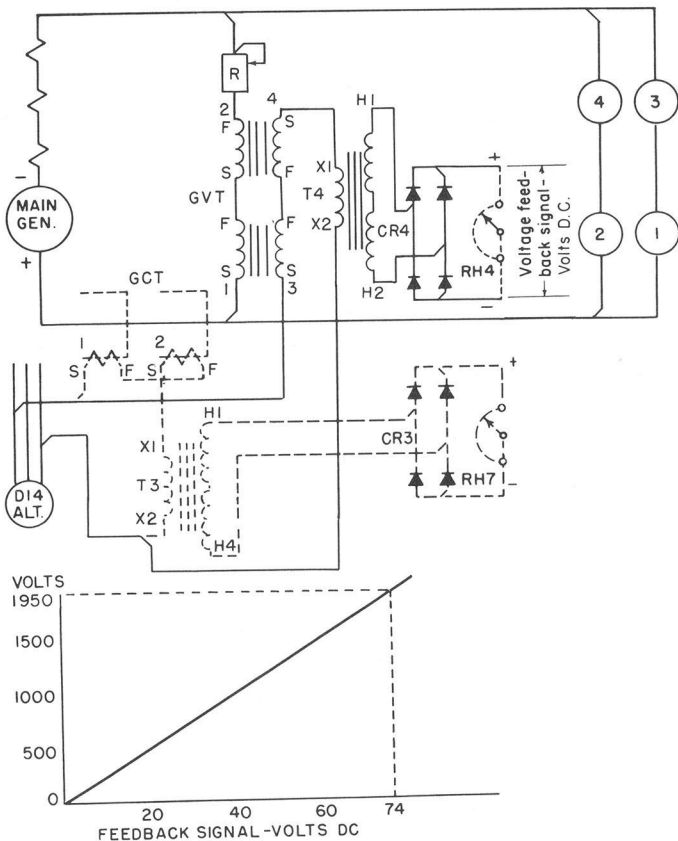

Fig. 1-11 — Voltage Feedback System

1209 I

EXCITATION SYSTEM

In Fig. 1-12 the two feedback signals have been connected in series so that their voltages add. The effect of increasing voltage is similar to that obtained by connecting two batteries in series.

If a straight line is drawn between the 1950 volt point where the voltage feedback signal is equal to 74 volts and the 3600 ampere point where the current feedback signal is equal to 74 volts, we will find that the sum of the two signals will be equal to 74 volts at any point on the line.

It is no coincidence that this straight line closely parallels that portion of the 2500 HP curve that is used in the series-parallel motor connection.

EXCITATION SYSTEM

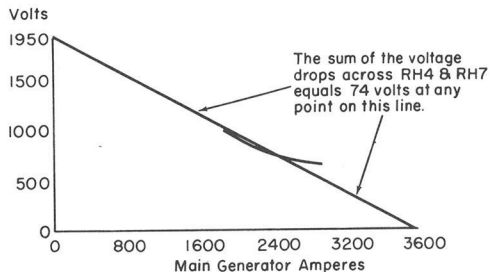
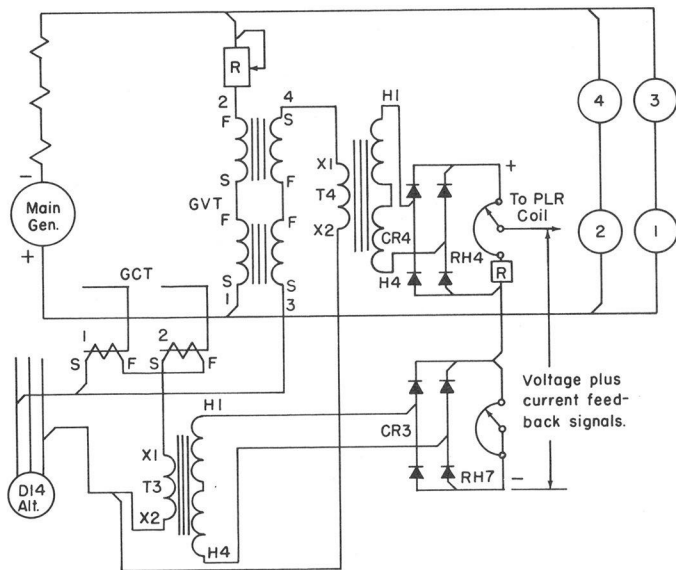

12093

Fig. 1-12 — Current Plus Voltage Feedback Signals

EXCITATION SYSTEM

In Fig. 1-13 the sum of the two feedback signals is compared to the voltage potential at the load regulator arm. This is done by connecting the two negatives together and tying the positive side of the feedback signal to the load regulator arm through the coil of a polarized relay, PLR. Thus any unbalance in voltage between the load regulator arm and the feedback signal will result in a current flow in the PLR coil. Current flow from 1 to 3 or zero current in PLR coil will cause PLR contacts 8 and 2 to open. This results in a major reduction in magnetic amplifier drive current, and the battery field excitation is reduced, with a resultant reduction in generator output.

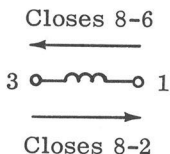

The rectifiers around the FM 11-12 coils are ten plate selenium. Each plate conducts after 0.5 volt is applied. Therefore, 5 volts must be applied before the rectifiers conduct. Since the DC control current from RH2 is applied at less than 3 volts, the rectifiers have no effect upon the control signal. It is the AC current developed in the magnetic amplifier 11-12 windings that the rectifiers suppress.

EXCITATION SYSTEM

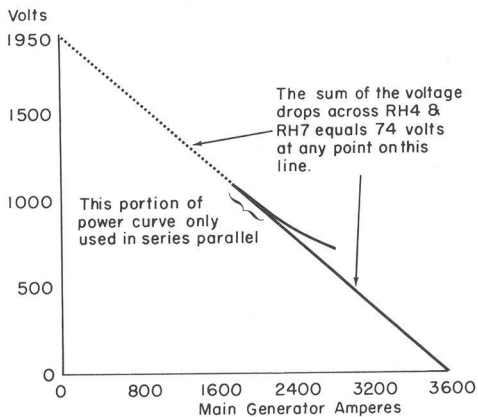
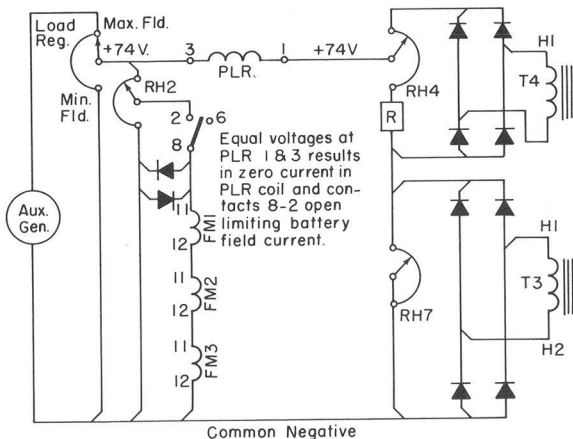

12094

Fig. 1-13 — Power Control, Series-Parallel Shunt

EXCITATION SYSTEM

Fig. 1-14 depicts a condition where the engine output is such as to result in a feedback signal of only 55 volts. Since with the load regulator in maximum field the voltage at its arm is 74 volts as compared to the 55 volt feedback signal, current flows from 3 to 1 in PLR coil. PLR contacts 8 and 2 close, resulting in full drive to the magnetic amplifier, hence full battery field excitation until feedback voltage equals 74 volts.

It follows then that the governor can control the load on the engine merely by moving the load regulator.

The system reacts so rapidly that fluctuation in power output is insignificant.

EXCITATION SYSTEM

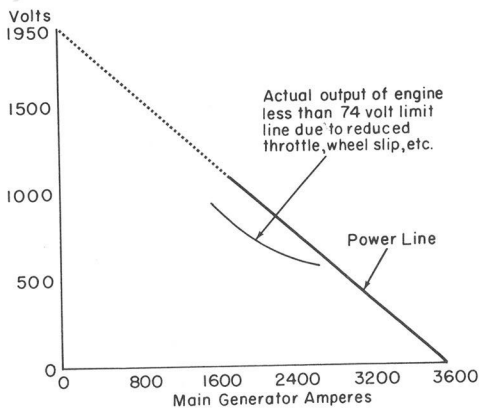
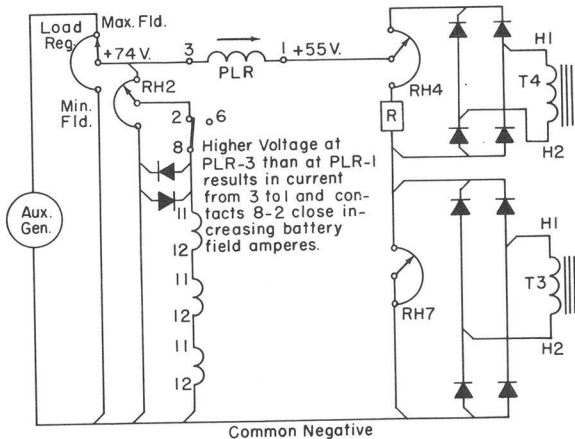

12095

Fig. 1-14 — Power Less Than Limit

EXCITATION SYSTEM

The second function of the performance control system, that of regulation to provide optimum power at train speeds between 12 and 18 miles per hour, is accomplished by changing the slope of the feedback signal line. This is done through use of rheostats RH5 and RH6 and field shunt auxiliary relay FSA contacts M1-M2 and N1-N2.

Notice that RH5 was indicated on the foregoing illustrations as a fixed resistance. This was done to avoid unnecessary complication of the power control explanation. The previous text covered performance control at locomotive speeds above 18 mph, therefore motor field shunting had occurred and FSA was picked up. With FSA picked up, RH5 is loaded on T4 and RH6 is shorted out.

Opening of FSA N1-N2 contacts changes the DC voltage drop from that across loading rheostat RH7 alone to that across RH6 plus RH7. This changes the anchor point of the power line from 3,600 to 2,550 amperes. Closing of FSA contacts M1-M2 changes the DC voltage drop from that across RH4 plus RH5 to that across RH4 alone. This changes the anchor point of the power line from 1950 to 3250 volts.

The power line identified as "B" in Fig. 1-15 is in effect when FSA is dropped out; that is, in series-parallel full field operation.

The effective portion of the line is shown darker than the complete line. Its upper limit is at 1,000 volts, which is

EXCITATION SYSTEM

the voltage limit of the main generator. The lower limit is explained in the following text.

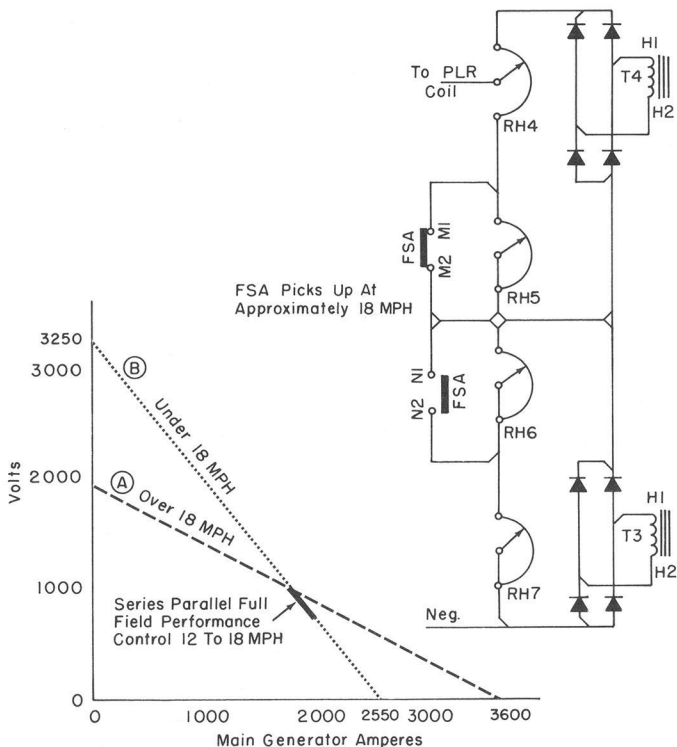

1 20 96

Fig. 1-15 — Power Control, 12 to 18 MPH

EXCITATION SYSTEM

The third function of the performance control system, that of regulating power out of the main generator to (nominally) 2,000 horsepower at locomotive speeds below 12 miles per hour to allow the locomotive to work at optimum speed and power within adhesion considerations, is accomplished by again changing the slope of the feedback signal line. This is done through use of rheostats RH11 and RH12 and rectifier CR9 as shown in Fig. 1-16.

RH12, connected as a voltage divider to a 74 volt DC source (PA wire), establishes the potential at CR9. When the signal from T3 (point A) exceeds the potential established by the setting of RH12 (point B), the loading of T3 is changed by effectively adding the resistance total of RH12 plus RH11 plus RE29 in parallel with RH6 and RH7, and the power line makes a sharp bend. RH12 is set to obtain this bend at locomotive speed of 12 miles per hour.

The slope of the line after the bend is determined by the setting of RH11. RH11 is set to bring about a slope that is in very close agreement with the 2,000 horsepower curve.

NOTE: The bend point and the slope of the line can be changed by the railroad to obtain varied performance characteristics as desired (within limits).

EXCITATION SYSTEM

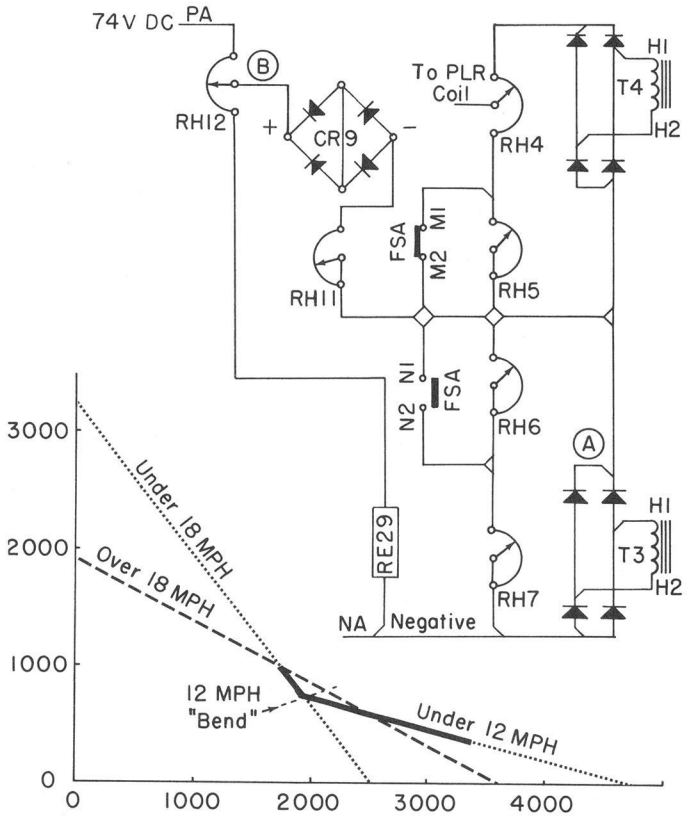

Fig. 1-16 — 2000 Horsepower Control

Fig. 1-17 depicts use of the performance control circuits to control and limit main generator amperes through the traction motor fields during dynamic braking. BR contacts disconnect PLR from the load regulator control and connect PLR to a zener diode and to the 24T wire from the brake control rheostat. The voltage feedback signal is cut out by a BKP1 interlock, and RH3 is inserted into the current feedback circuit by another BKP1 interlock. The 2,000 horsepower control circuit (RH11, RH12, and CR9) does not go into effect during dynamic braking because the signal from T3 never exceeds the potential at the brush arm of RH12.

When generator current results in a feedback signal that is greater than the signal from the brake control rheostat, PLR contacts close 8 - 6 and interrupt current to the magnetic amplifier drive coils. When the generator current exceeds 975 amperes the current feedback signal is greater than the maximum signal from the brake control rheostat. This limits maximum generator current.

Dynamic brake circuits are further explained in Section 3 of this handbook.

Elimination of the voltage feedback signal results in the vertical limit line shown on the graph.

FOLD OUT FOR FIG. 2-0

SECTION 2

TRANSITION CONTROL

The GP35 locomotive utilizes 16 transition positions to cover its speed range from 18 to 71 miles per hour (62:15 gear ratio). These positions are as follows (the percentages given are nominal):

1. Series-Parallel - Full Motor Field Strength
2. Series-Parallel - 20% Motor Field Shunt
3. Series-Parallel - 35% Motor Field Shunt
4. Series-Parallel - 44% Motor Field Shunt
5. Series-Parallel - 51% Motor Field Shunt
6. Series-Parallel - 57% Motor Field Shunt
7. Series-Parallel - 61% Motor Field Shunt
8. Series-Parallel - 65% Motor Field Shunt
- * 9. Series-Parallel - 68% Motor Field Shunt
(65% When In Effect)
- *10. Series-Parallel - 70% Motor Field Shunt
(65% When In Effect)
11. Parallel - Full Motor Field Strength
12. Parallel - 20% Motor Field Shunt
13. Parallel - 35% Motor Field Shunt
14. Parallel - 44% Motor Field Shunt
15. Parallel - 51% Motor Field Shunt
16. Parallel - 57% Motor Field Shunt

*See Fig. 2-13 and related text.

TRANSITION CONTROL

These 16 transition positions or steps are automatically controlled by two E-I type transition relays, FTR and BTR. Forward transition relay FTR, by picking up, initiates all forward transitions during train acceleration. Backward transition relay BTR, by dropping out, initiates all backward transitions during train deceleration.

A third E-I type relay, PTR, responds to maintain the percentage of motor field shunt within tolerable limits when motor fields are hot.

Considerable circuit simplification is accomplished through use of a multiple pole ten position motor driven cam switch called a program switch. This device derives its name from its function of programming the locomotive through 16 transition positions, 10 in series-parallel and 6 in parallel. The 10 positions in series-parallel are obtained by the first complete (360 degree) revolution of the program switch; the 6 positions in parallel are obtained by the program switch rotating past position 10 to position 6 while motors are connected in parallel.

TRANSITION CONTROL

Four motor field shunting contactors FS1, FS2, FS3, and FS4 are used individually and in combination to obtain nine steps of motor field shunting. The combinations are as follows:

FS1	20% Motor Field Shunt
FS2	35% Motor Field Shunt
FS1 - FS2	44% Motor Field Shunt
FS3	51% Motor Field Shunt
FS4	57% Motor Field Shunt
FS1 - FS4	61% Motor Field Shunt
FS2 - FS4	65% Motor Field Shunt
*FS1 - FS2 - FS4	68% Motor Field Shunt (65% When In Effect)
*FS3 - FS4	70% Motor Field Shunt (65% When In Effect)

The percentages of shunt given are calculated using the electrical resistance of traction motor fields when hot during normal operation. For this reason the last two steps of shunt exceed the 65% allowed by the transition control system. When the traction motor fields are cold, all percentages would decrease and the percentage of shunt accomplished by the last two steps would fall below or at 65%.

* See Fig. 2-13 and related text.

TRANSITION CONTROL

Each of the FS contactors, as well as the transition relay TR, is controlled by its own switch on the program switch. These switches are designated TPS1 through TPS9.

TPS1 is used in conjunction with a positioner relay TPR to position the cam shaft of the program switch in the exact center of each of the 10 positions. TPS1 is closed only between positions and opens in the center of each position. The remaining eight switches open or close a minimum of five degrees ahead of TPS1. This insures that all the remaining switches are in the proper position when the program switch is at rest.

TPS2 opens in position 1. This prevents the program switch from rotating backward past position 1 in the series-parallel portion of its rotating cycle. During parallel motor connection an interlock of a parallel power contactor shorts out TPS2 switches and the program switch may rotate backward past position 1 to position 10.

TRANSITION CONTROL

TPS3, 4, 5, and 6 operate field shunting contactors.

TPS7 prevents FTR knockdown during transition from series-parallel to parallel.

TPS8 sets up the circuit for pickup of transition relay TR to accomplish transition from series-parallel to parallel.

TPS9 A-B contacts are open in transition position 1 parallel to prevent BTR pickup as a result of interrupter relay IR action. This insures positive program switch action and circuit sequencing. TPS9 C-D contacts are used as a brake interlock on units equipped with dynamic brakes.

TRANSITION CONTROL

Fig. 2-1 shows the transition control circuit with the transition program switch in position 1, series-parallel. S13 and S24 are picked up and the motors are connected in series-parallel full field. Since the locomotive is traveling at very slow speed, neither the forward transition relay FTR nor the backward transition relay BTR has picked up. The parallel transition relay PTR is not connected in the transition circuits at this time.

TPS2 of the transition program switch and the C-D auxiliary contacts of parallel power contactor P1 are open when the switch is in position 1, series-parallel. This prevents energy from reaching the program switch armature and driving the switch backward past position 1.

In the following text we will assume that the locomotive is operating at full power; that is, with the throttle in Run 8 position.

TRANSITION CONTROL

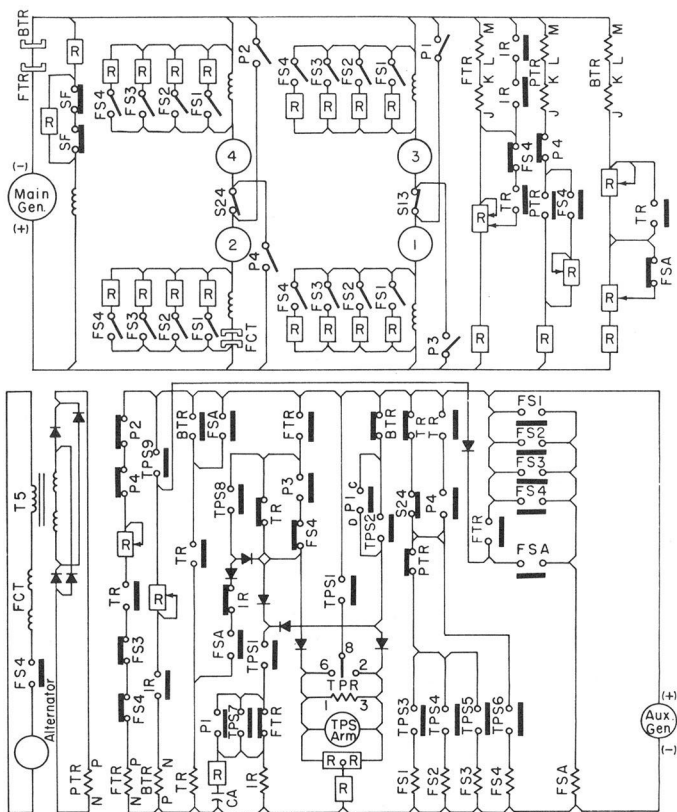

1 2099

Fig. 2-1 — Starting A Train

TRANSITION CONTROL

In Fig. 2-2 the locomotive has accelerated the train to a speed resulting in a system voltage of 925 at approximately 1,800 main generator amperes. At this point BTR picks up, but FTR is still dropped out. Field shunt auxiliary relay FSA contacts A1-A2 being dropped (closed) at this time lower the pickup value of BTR, but it is incidental at this time since BTR is calibrated to pick up ahead of FTR regardless of the FSA A1-A2 contacts. The resistors in the circuits to their J-K, L-M coils are so calibrated that BTR will pick up at lower main generator voltage and drop out after FTR has dropped out.

BTR picking up did not make or break any circuits. It simply set up the condition whereby BTR dropout can cause the program switch to step backward after it has stepped up.

TRANSITION CONTROL

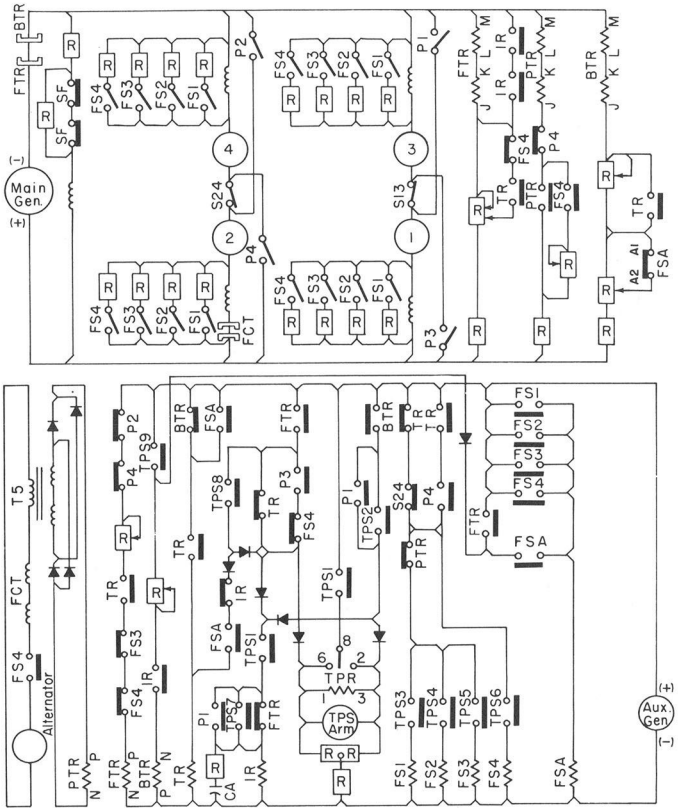

12100

Fig. 2-2 — Accelerating - BTR Picks Up

TRANSITION CONTROL

In Fig. 2-3 the locomotive has reached a speed of approximately 19 MPH. The FTR relay picks up at approximately 1,000 volts and 1,750 amperes out of the main generator. FTR contacts C-D close, allowing current to flow from the positive side of the auxiliary generator through normally closed contacts A1-A2 of transition relay TR, and through the transition program switch motor armature to cause the program switch to rotate from position 1 toward position 2.

The voltage drop across the armature causes current to flow from 1 to 3 in the coil of transition switch positioner relay TPR. This causes TPR contacts to close 8 - 6.

TRANSITION CONTROL

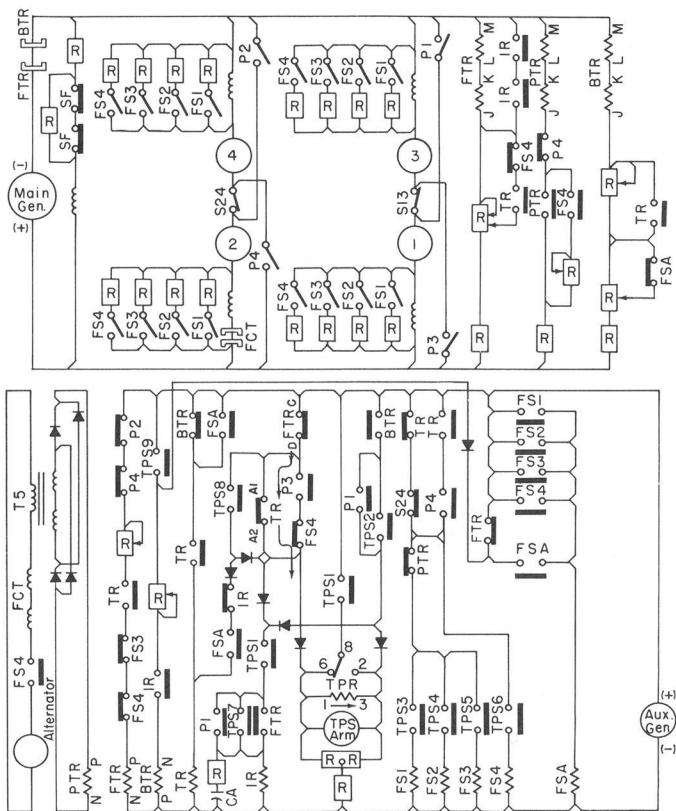

12101

Fig. 2-3 — Accelerating - FTR Picks Up

TRANSITION CONTROL

The program switch is now moving from position 1 toward position 2. It will require less than 1 second to reach the center of position 2. Fig. 2-4 shows the conditions existing after approximately 9 degrees of rotation. At this point, as can be seen from the cam development chart, TPS1 contacts close. This provides a parallel path and the program switch armature can now receive energy through TPS1 C-D contacts and TPR 8-6 contacts.

TRANSITION CONTROL

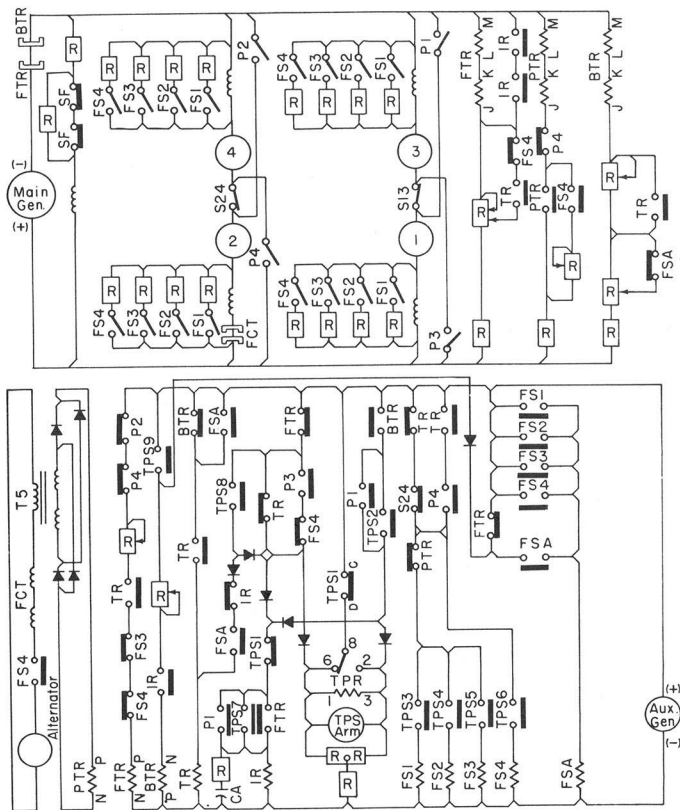

12102

Fig. 2-4 - TPS1 Contacts Close

TRANSITION CONTROL

In Fig. 2-5 the program switch has rotated approximately 20 degrees and has entered position 2. At this point TPS2, TPS3, and TPS7 contacts close. A-B contacts of TPS9 also close.

TPS2 contacts closing has no effect at this time, but it sets up the circuit to drive the program switch back to position 1 should locomotive speed decrease.

TPS3 contacts closing pick up motor field shunting contactor FS1. The C-D contacts of FS1 close to pick up FSA.

TPS7 contacts closing energizes interrupter relay IR. The closing of IR contacts A-B and C-D shorts out FTR J-K, L-M coils, but for purposes of explanation and clarity, at the instant depicted in Fig. 2-5, FTR has not yet dropped out.

TPS9 A-B contacts are now closed, and the closing of IR contacts E-F allows auxiliary generator current to energize BTR N-P coil with 300 milliamperes control current. This will hold BTR picked up when main generator voltage drops as a result of motor field shunting. The closing of TPS9 A-B contacts will also prevent accidental FSA dropout during changes in motor field shunting.

In Fig. 2-6, FTR has dropped out. The opening of FTR C-D contacts interrupts the flow of current to the IR relay coil, but the IR relay remains picked up due to energy stored in capacitor CA26. The capacitor will keep IR picked up for approximately 1 second.

The program switch motor armature receives energy through TPS1 C-D contacts and TPR 8-6 contacts. The transition program switch continues to rotate toward the center of position 2.

TRANSITION CONTROL

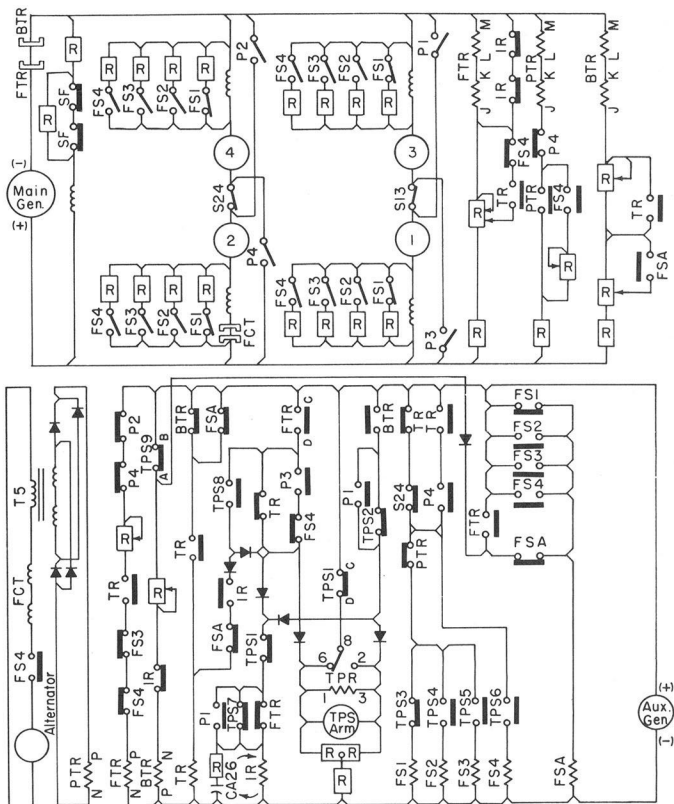

12104

Fig. 2-6 — Stepping Up — FTR Drops Out

TRANSITION CONTROL

In Fig. 2-7 the program switch has reached a point within approximately 9 degrees of the center of position 2. At this point TPS1 contacts open. This interrupts the flow of current to the program switch motor armature. Since the motor has permanent magnet field poles, a current is generated by the rotation of the armature in these fields. This current is dissipated in the resistors below the armature and acts as a dynamic brake which stops the armature abruptly. Since current no longer flows to the motor and through the TPR coil, TPR contacts 8-6 open.

The IR relay drops out when the charge in capacitor CA26 is exhausted. This removes the short from around FTR J-K, L-M coils and interrupts the flow of current to the N-P coil of BTR. The delayed dropout of IR allowed generator voltage to stabilize and conditions are now set for the program switch to step up if locomotive speed increases, or to step down if speed decreases.

FS1 is held picked up by TPS3 which is always closed in position 2.

FSA is held in by FS1 C-D auxiliary contacts and TPS9 A-B contacts.

TPS2 being closed makes it possible for BTR to drive the program switch to position 1 should BTR drop out due to a loss of locomotive speed.

TRANSITION CONTROL

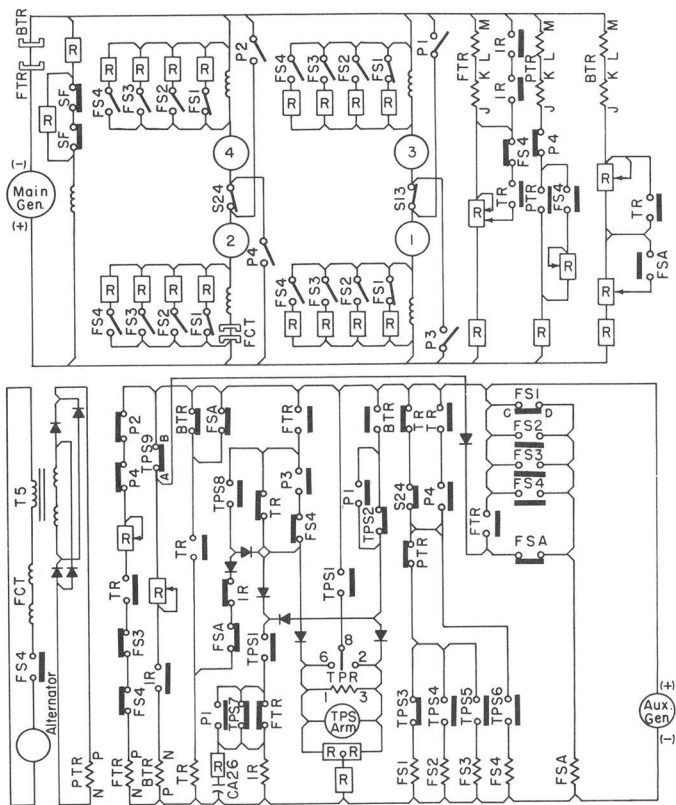

12105

Fig. 2-7 — Program Switch Stopping In Position 2

As the locomotive continues to accelerate, the program switch will step up each time FTR picks up. The sequence of events for each step through position 9 is like that of going from position 1 to 2. However, a compensation circuit is involved after step 5. The circuit will be explained in the article for position 6.

In Fig. 2-8 the position of the various contacts is shown after the program switch has stopped in position 3 and the IR relay has dropped out.

The traction motor fields are now shunted approximately 35% and the system voltage is about 950 volts.

TRANSITION CONTROL

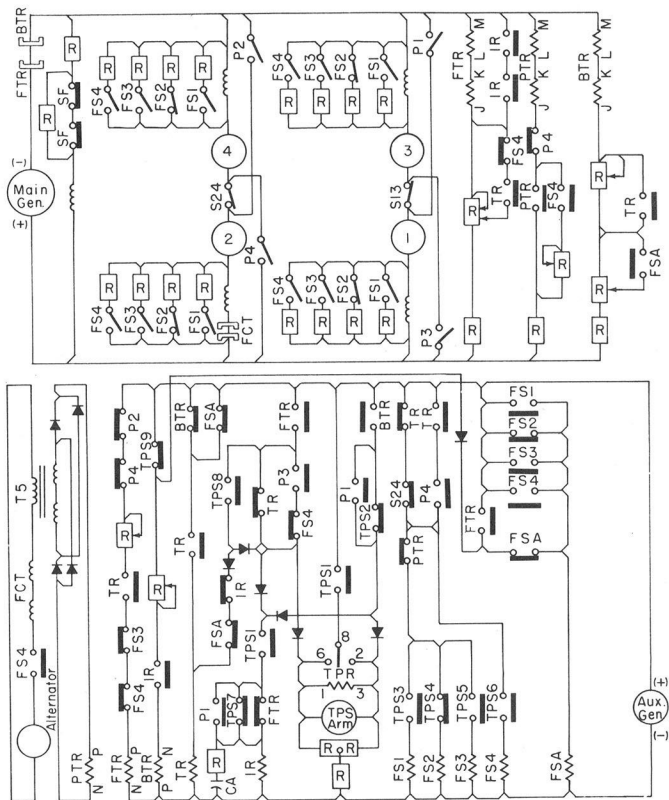

Fig. 2-8 — In Position 3 - 35% Shunt

12106

As the locomotive continues to accelerate, the program switch has moved to position 4 as shown in Fig. 2-9. FS2 remains picked up and FS1 is picked up again, putting two resistors in parallel across the motor fields. This results in 44% shunt.

Since the system voltage drops only to 950 volts due to the 44% shunt, FTR does not pick up nor does BTR drop out.

TRANSITION CONTROL

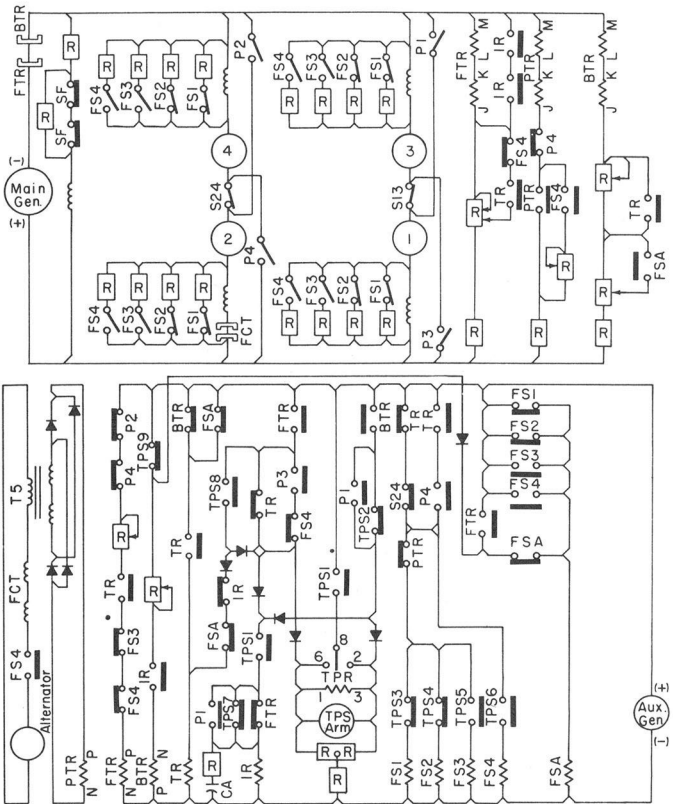

12107

Fig. 2-9 — In Position 4 - 44% Shunt

TRANSITION CONTROL

In Fig. 2-10 the program switch has stopped in position 5. FS1 and FS2 have dropped out and FS3 has picked up. This results in approximately 51% motor field shunt.

As a result, the system voltage has dropped to 950 volts.

The pickup of FS3 contacts E-F has no fuction at this time.

TRANSITION CONTROL

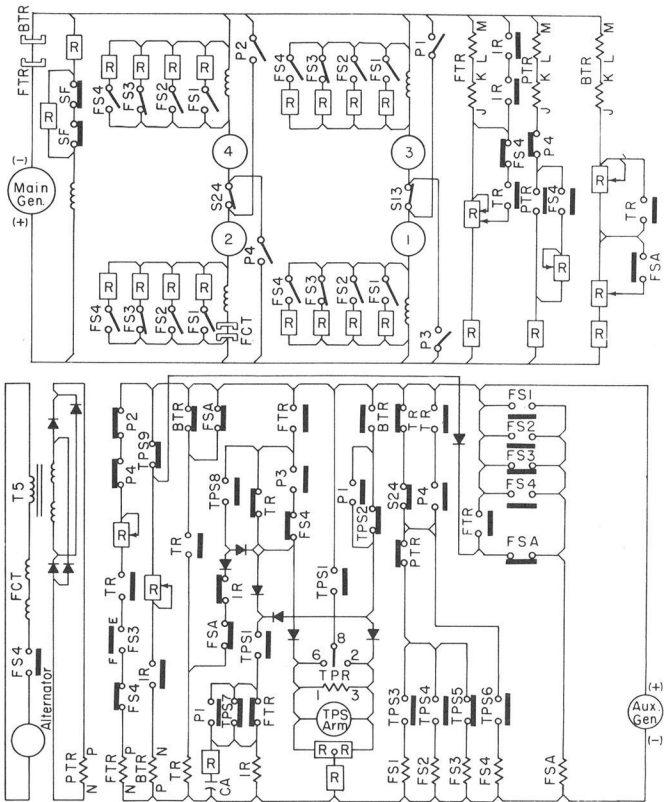

12108

Fig. 2-10 - In Position 5 - 51% Shunt

TRANSITION CONTROL

In Fig. 2-11 the program switch has stopped in position 6. FS3 has dropped and FS4 has picked up. This results in approximately 57% motor field shunt. The resultant drop in traction motor field strength drops the system voltage to approximately 950 volts.

The A-B contacts of FS4 have now connected the parallel transition relay PTR across the main generator, and the J-K contacts of FS4 have connected the field current transducer FCT in series with transformer T5 across the alternator. Pickup of FS4 contacts E-F and Q-R has no function at this time.

Understand, however, that action of PTR does not directly bring about transition to full parallel motor connection, nor does it bring about steps of motor field shunting. The purpose of PTR operating in conjunction with field current transducer FCT is to hold the percentage of motor field shunting within allowable limits when traction motor fields are hot. This holding action interrupts a portion of the shunt around the motor fields; and the transition system, seeing the need for more shunt, causes the program switch to step up and initiate transition from series-parallel to parallel motor connection.

PTR action is explained following Fig. 2-12.

In Fig. 2-12 the program switch has stopped in position 7. FS4 remains picked up and FS1 is picked up again, putting two resistors in parallel across the motor fields. This results in 61% shunt, assuming that the traction motor fields are relatively cool.

System voltage has dropped to 950 volts at approximately 1,830 main generator amperes.

In Fig. 2-13 we assume that operating conditions are such that the traction motor fields are hot and that field resistance has increased from a nominal 0.0096 ohm for cool motors to a nominal 0.012 ohm for hot motors.

If then, resistors FS4 and FS1 are connected in parallel across the motor fields, the shunting resistors being relatively cool as compared to the motor fields draw a greater percentage of current. This effective percentage of shunt may be greater than that allowable, and damage to the traction motor armatures could occur as a result of ringfire.

To prevent an excessive percentage of motor field shunting, PTR will pick up to interrupt control current to FS1. This is accomplished by action of field current transducer FCT.

During normal operation in series-parallel, when FS4 has picked up, motor field current flowing in the cables that pass through the frame of FCT acts to decrease the impedance of the FCT coils. With decreased impedance, current flows through the primary of transformer T5, with resulting current flow in the secondary of T5 and through the P-N coil of PTR. Flow from P to N in the coil opposes PTR pickup and PTR E-F contacts remain closed.

TRANSITION CONTROL

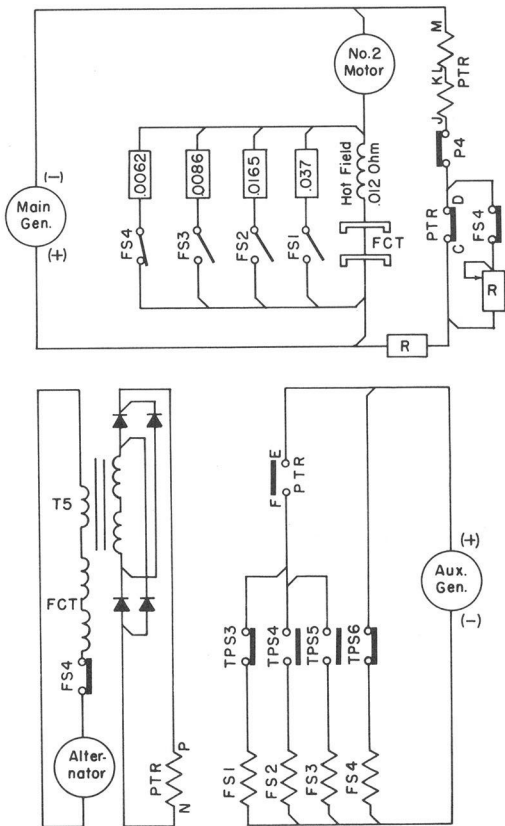

12111

Fig. 2-13 — Field Shunt Compensation In Effect

However, if the motor fields are hot, the increased resistance causes less current to flow through the cables passing through the frame of FCT. The flux density in the core of FCT decreases and the impedance of the FCT coils increases. Current flow through T5 and consequently in the P-N coil of PTR is not sufficient to hold PTR dropped out, and the J-K, L-M coils pick up PTR.

In this example PTR E-F contacts pick up to interrupt the flow of current to the coil of FS1 even though the program switch position calls for pickup of FS1.

The C-D contacts of PTR close to recalibrate the pickup of PTR and hold PTR in to prevent cycling.

TRANSITION CONTROL

PTR action compensates for hot motor fields and prevents excessive motor field shunting. Since the motor fields lose all shunt except FS4 whenever PTR picks up, system voltage remains high, calling for more shunt. The program switch will continue to step up until transition to parallel motor connection occurs.

PTR pickup can take place during series-parallel motor connection at any time after FS4 picks up during the sixth program switch position. Actually, under usual operating conditions PTR will pick up before the program switch steps into position 9. It is only when the motor fields are cold that the ninth and tenth shunting positions of the program switch are needed.

In Fig. 2-14 the program switch has stopped in position 8. FS4 remains picked up, but FS1 has dropped out and FS2 has picked up, putting resistors of different value in parallel. This results in 65% shunt.

Since the system voltage drops only to 955 volts due to the 65% shunt, FTR does not pick up nor does BTR drop out.

TRANSITION CONTROL

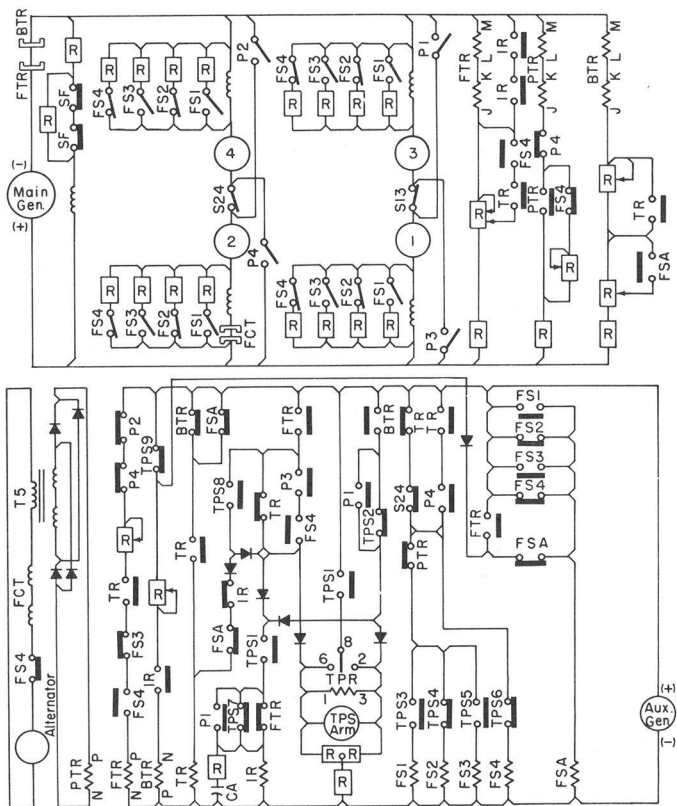

Fig. 2-14 — In Position 8 - 65% Shunt

12112

TRANSITION CONTROL

In Fig. 2-15 the program switch has stopped in position 9. FS4 and FS2 remain picked up, and FS1 has picked up again, putting three resistors in parallel. This will result in 65% shunt or less.

As a result the system voltage has dropped to 955 volts.

Notice that the percentage of shunt in position 9 is shown as 65%. This is the same percentage that is given for position 8. The reason for the apparent discrepancy lies in the fact that shunting percentages are calculated with traction motor fields warm as during normal operation, and that the PTR circuit previously discussed will not allow more than 65% shunt. Therefore, the program switch will normally step through positions 9 and 10 and into full parallel transition.

It is only when the motor fields are exceptionally cool that steps 9 and 10 are in effect, and at that time the percentage of shunt will not exceed 65%.

TRANSITION CONTROL

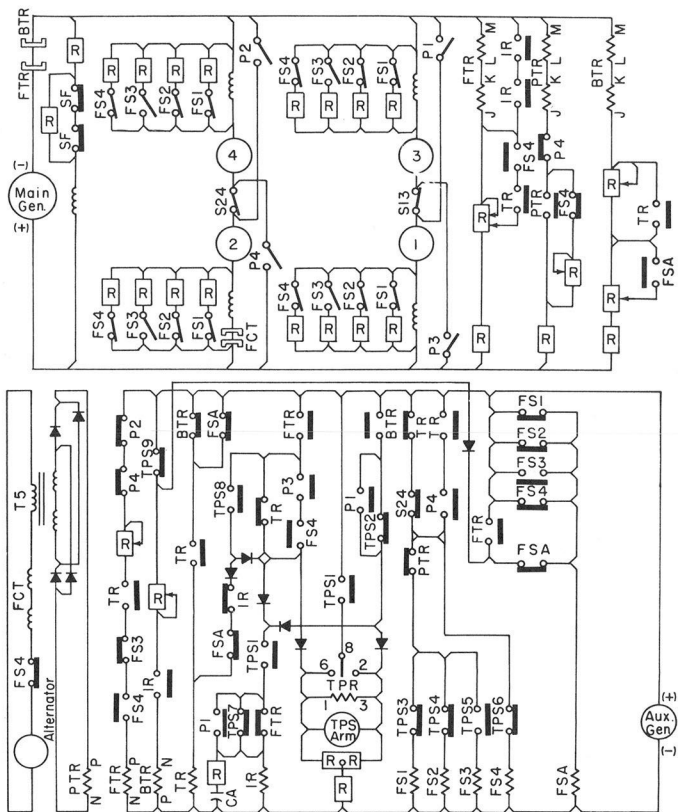

12113

Fig. 2-15 — In Position 9 - 65% Shunt

In Fig. 2-16 FTR has picked up and the program switch has rotated approximately 9 degrees out of position 9. TPS1 picks up and TPR contacts close 8 - 6. At this instant the program switch has not rotated far enough to pick up other contacts nor to drop those already picked up. Therefore TPS7 is still closed and IR picks up, but for purposes of explanation, FTR is not shown dropped out.

TRANSITION CONTROL

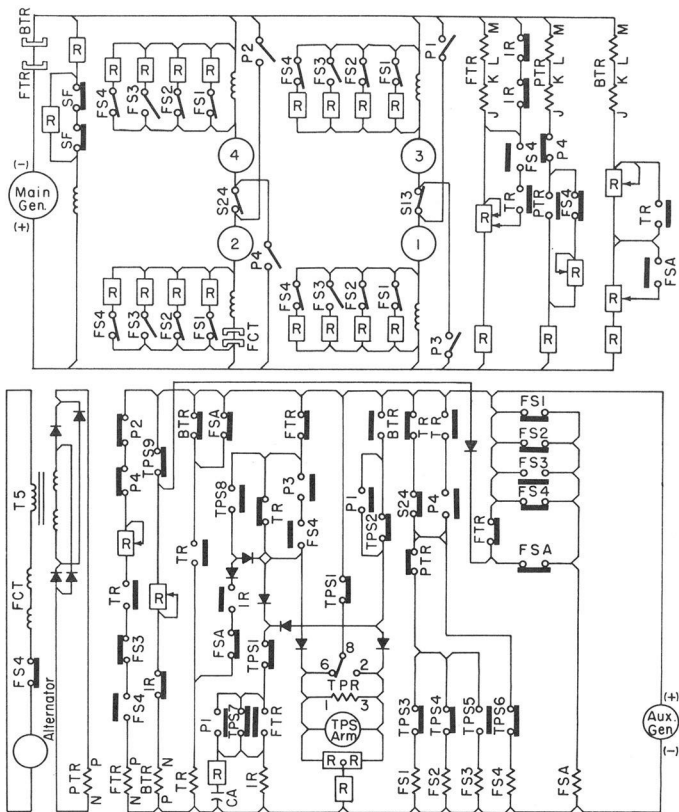

12114

Fig. 2-16 - Stepping Up From Position 9

In Fig. 2-17 the program switch has rotated 20 degrees out of position 9. TPS3 and TPS4 open, dropping FS1 and FS2. TPS7 opens and FTR drops out, but IR is still held picked up by the charge in capacitor CA26.

*Property Of
National Museum of Transport
Library*

TRANSITION CONTROL

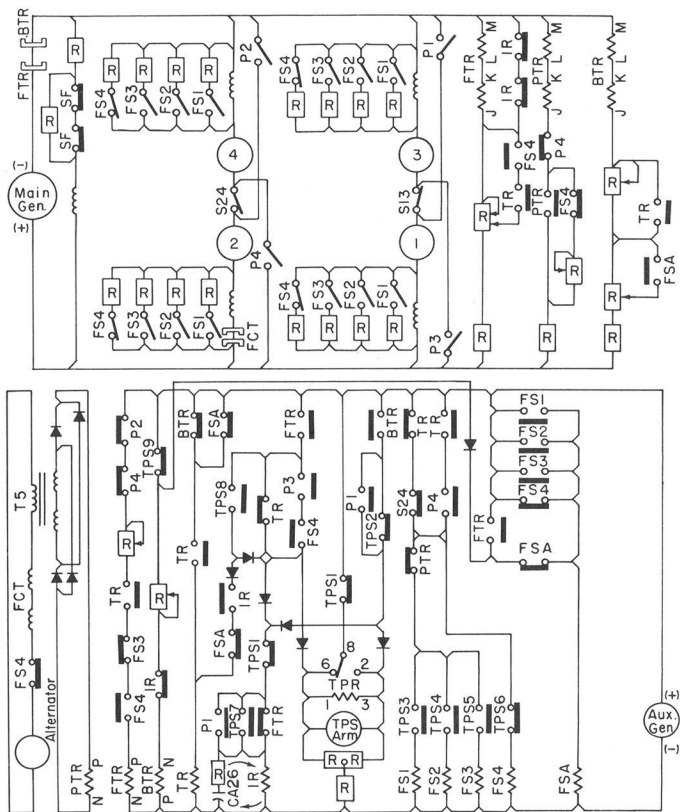

12115

Fig. 2-17 — Stepping Up From Position 9 - FTR Dropped

In Fig. 2-18 the program switch has stopped in position 10. FS1 and FS2 have dropped out and FS3 has picked up, putting two resistors in parallel across the motor fields. This results in 65% shunt.

TPS8 contacts have closed, but since they closed after FTR dropped out, the current path to transition relay TR was not completed. The path is, however, set up to energize TR the next time FTR picks up.

The foregoing sequence from step 6 through step 10 will take place even though PTR picks up at some time after FS4 picked up in position 6. That is, the program switch will step up through position 10, but the field shunting contactors with the exception of FS4 will not be energized. Notice that the C-D contacts of PTR lock PTR picked up against cycling when PTR E-F contacts opening causes FS1, FS2, or FS3 to drop out.

TRANSITION CONTROL

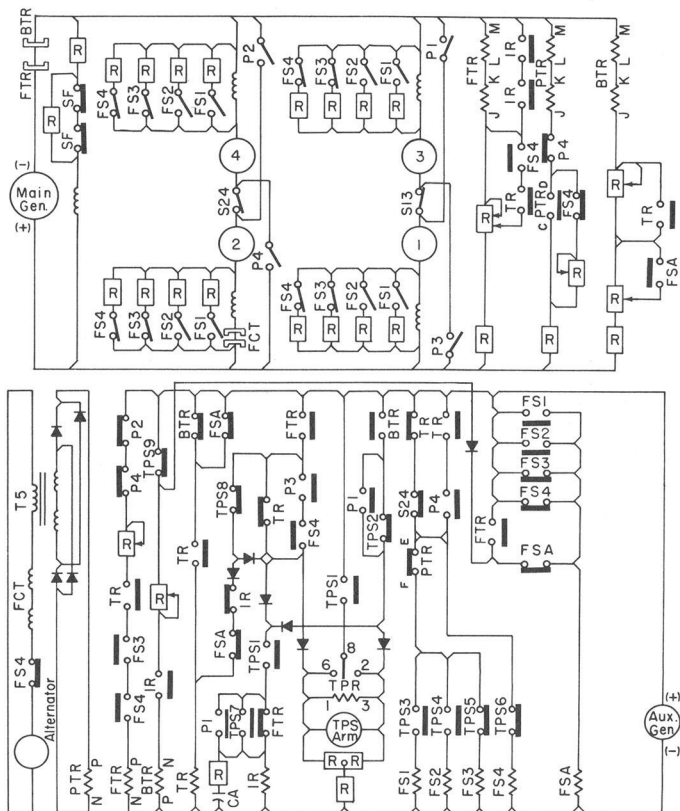

12116

Fig. 2-18 — Stopped In Position 10 - TR Set Up

TRANSITION CONTROL

In Fig. 2-19 FTR has picked up and control current flows through closed contacts of TPS8 to the program switch armature and also through closed contacts J-K of IR and through closed contacts R1-R2 of FSA to energize TR. The A-B contacts of TPS9 open as the program switch rotates.

TRANSITION CONTROL

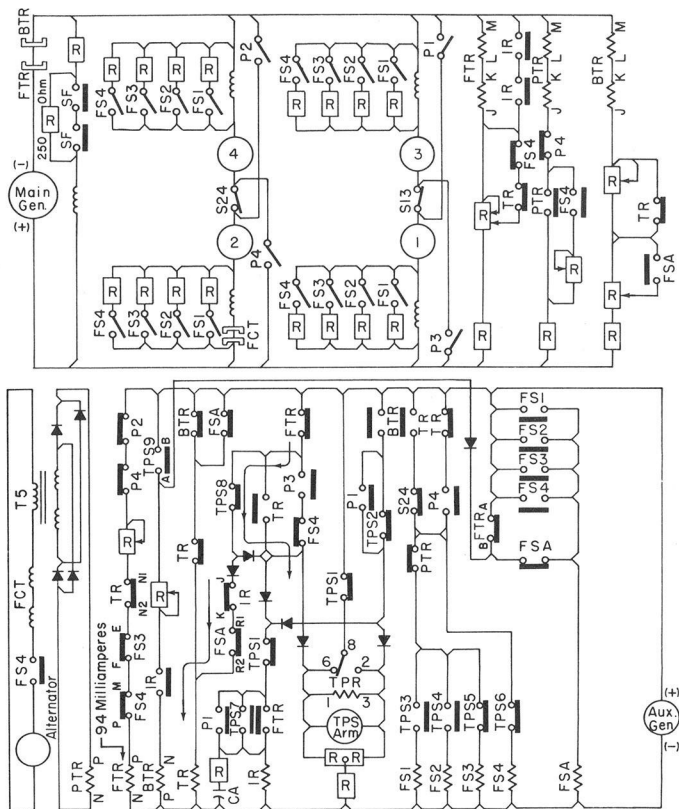

12117

Fig. 2-19 — Stepping Up From Position 10 - FTR Pickup, TR Pickup

TRANSITION CONTROL

When TR picks up, the flow of current to the FS contactors is interrupted and all shunt is removed from the motor fields. Simultaneously, the pickup of C1-C2 contacts of TR, shown in Fig. 2-20, causes shunt field contactor SF and battery field contactor BFA to drop out. BFA dropping out removes all excitation from the main generator battery field. SF dropping out inserts 250 ohm resistance into the shunt field circuit, and the system voltage decays at a rate which requires 2-1/2 seconds to drop from 1,000 volts to approximately 500 volts. The reduction of power is controlled at this rate to make transition as smooth as possible without loss of speed.

Notice that TPS7 is open in position 10; therefore, no current flows to the IR coil and FTR J-K, L-M coils are not shorted out. However, pickup of TR contacts N1-N2 and dropout of FS3 E-F and FS4 M-P contacts allows 94 milliamperes control current to flow through the P-N coil of FTR. This recalibrates FTR dropout to approximately 500 volts at low generator current. FTR will then drop out in about 2-1/2 seconds while generator volts are dropping to 500.

In the meantime FTR contacts A-B remain closed to keep FSA energized. This is the sole purpose of FTR A-B contacts.

TRANSITION CONTROL

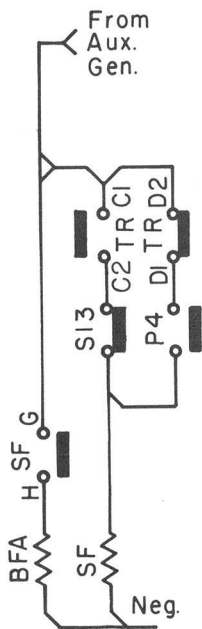

12118

Fig. 2-20 — SF And BFA Coils

Fig. 2-21 shows the next step toward accomplishing series-parallel to parallel motor transition. System voltage has decayed to 500 volts and FTR dropped out. FTR A-B contacts opening drop out FSA, and FSA D1-D2 contacts opening drops S13. S13 A-B contacts close to energize P1 and P3 through closed F1-F2 contacts of TR. P1 picks up to drop S24, and S24 A-B contacts closing energize P2 and P4.

In the meantime the program switch has rotated past position 10 to position 1 - Full Parallel. This is unlike the GP30 transition control system which utilizes 10 program switch positions, and does not allow the program switch to rotate past position 10.

TRANSITION CONTROL

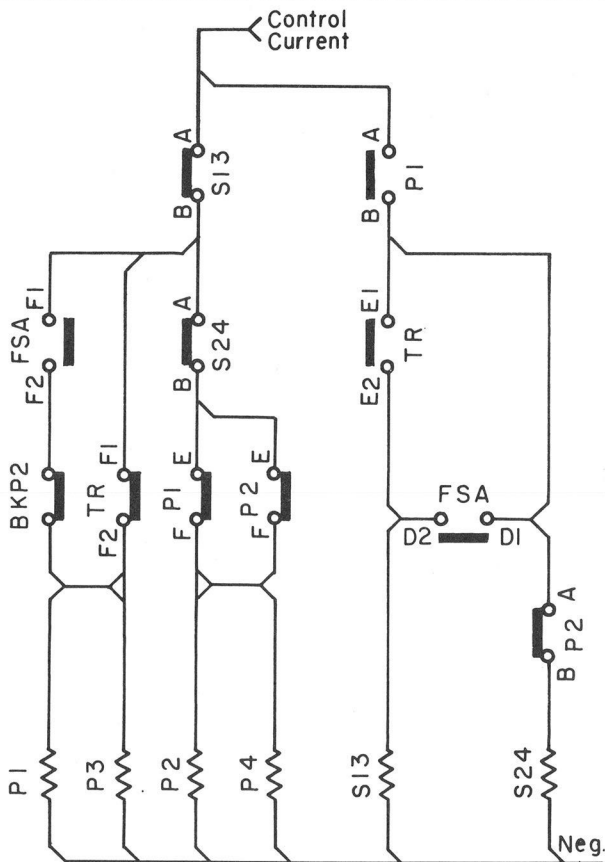

12119

Fig. 2-21 — Sequence Circuit Series-Parallel To Parallel Transition

TRANSITION CONTROL

In Fig. 2-22 the program switch has rotated past position 10 and has stopped in position 1. The motors are now connected in parallel full field. Notice that the C-D contacts of parallel power contactor P1 have shorted out TPS2 contacts which are open in position 1. This allows the program switch to step back to position 10 should locomotive speed drop.

The C-D contacts of P2 and P4 have opened to remove control current from the FTR P-N coil and the FTR J-K, L-M coils are free to pickup FTR should locomotive speed increase.

TR R1-R2 contacts have closed to recalibrate FTR pickup in parallel motor connection.

The program switch can now step from position 1 up through position 5 in parallel in much the same way that it stepped in series-parallel.

Notice that the A-B contacts of P4 interrupt the circuit to the J-K, L-M coils of PTR during parallel transition.

TRANSITION CONTROL

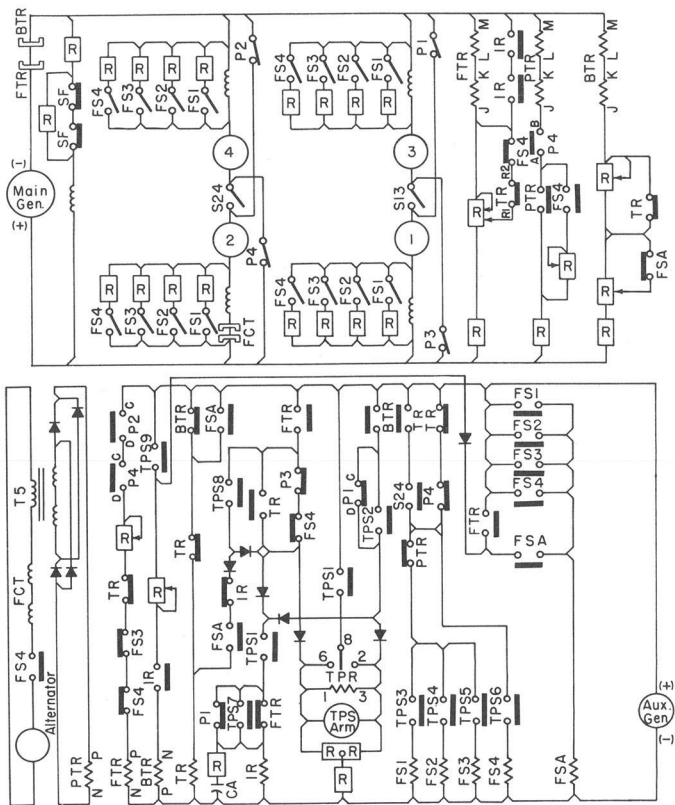

12121

Fig. 2-22 — In Position 1 Parallel Full Field

Fig. 2-23 shows the program switch in position 5 parallel (15th position). This is comparable to position 5 series-parallel. FS3 has picked up and all other field shunt contactors have dropped out. However, the A1-A2 contacts of TR are open, and when FTR again picks up the program switch motor gets its energy through E-F contacts of P3 and FS4.

TRANSITION CONTROL

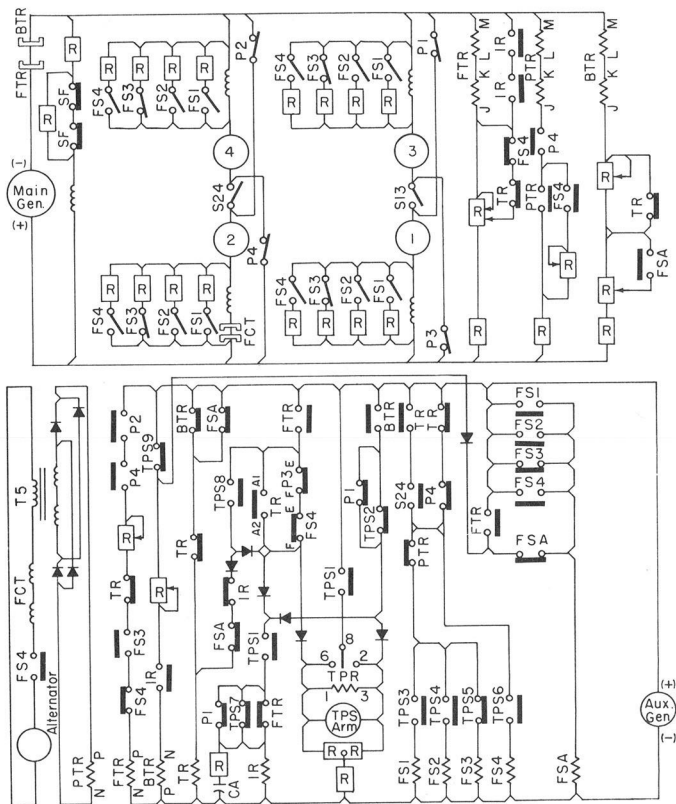

12122

Fig. 2-23 — In Position 5 Parallel, 51% Shunt

In Fig. 2-24 FTR has picked up and the program switch has rotated 20 degrees toward position 6. IR has picked up to short out FTR J-K, L-M coils, but for purposes of explanation, FTR is not shown dropped.

The program switch has not rotated far enough to drop out TPS5 or to pick up TPS6.

TRANSITION CONTROL

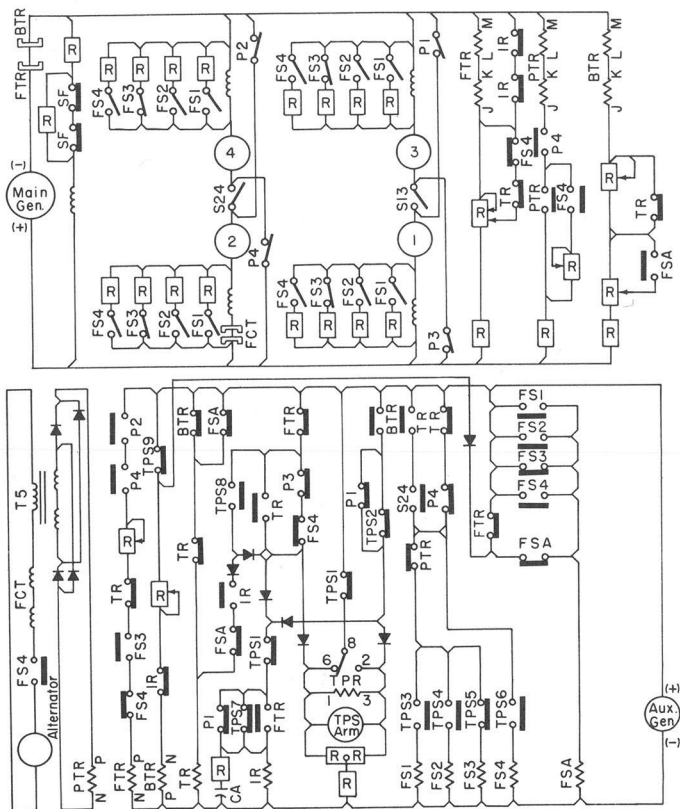

12123

Fig. 2-24 - Stepping Up To Position 6 Parallel

In Fig. 2-25 the program switch has stopped in position 6, parallel. FS3 has dropped out and FS4 has picked up. The E-F contacts of FS4 picking up, eliminate the possibility of feed to the program switch armature should FTR pick up again. This is therefore the final step of parallel motor field shunt.

The A-B contacts of FS4 pick up, but since the A-B contacts of P4 are open, the PTR J-K, L-M coils are not energized. The L-M contacts of FS4 merely act to hold PTR dropped out.

The J-K contacts of FS4 open and FTR pickup is recalibrated to the series-parallel value. At that higher pickup value locomotive speed must reach approximately 75 miles per hour (62:15 gear ratio) before FTR again picks up. FTR picking up indicates true train overspeed or 8-wheel simultaneous slip, and the WS relay is energized.

TRANSITION

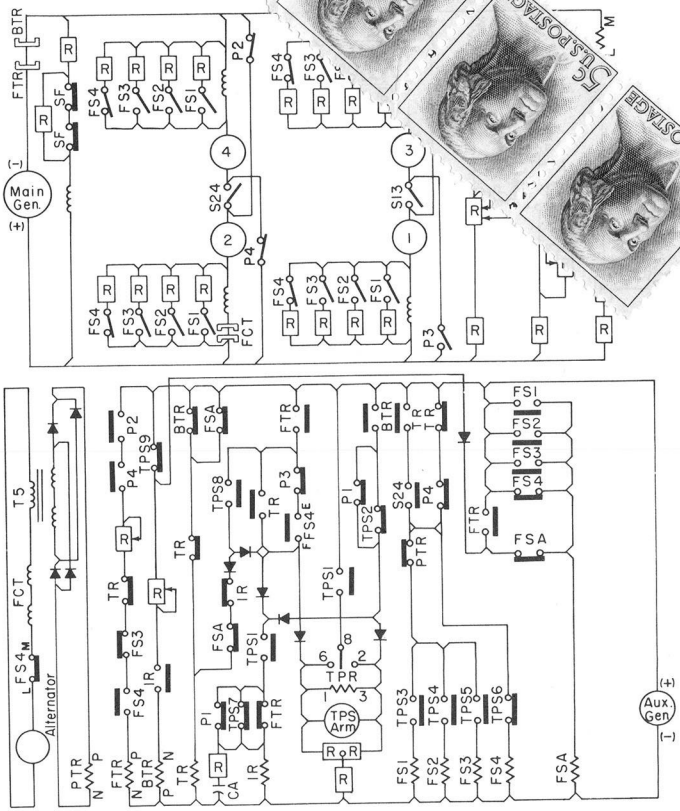

12124

Fig. 2-25 - Stopped In Position 6 Parallel

Should the locomotive decelerate due to an increase in grade, the program switch will step down in a manner similar to its stepping up.

In Fig. 2-26 the locomotive has decelerated to a point where the system voltage has dropped below the 800 volt dropout value of BTR. BTR has dropped out. FTR had not picked up in position 6, parallel. The program switch armature is energized in a direction to start it rotating toward position 5. Simultaneously, current from 3 to 1 in the TPR coil causes its contacts 8 to 2 to close.

BTR E-F contacts close to energize the overriding solenoid in the engine governor and drive the load regulator toward minimum field position, thereby maintaining stable generator voltage.

In Fig. 2-27 the program switch has moved approximately 9 degrees toward position 5, parallel.

TPS1 contacts have closed, and the IR relay has picked up, shorting out the FTR coils and energizing the BTR N-P coil with 300 milliamperes control current. But for purposes of explanation BTR has not yet picked up.

The program switch continues to rotate toward position 5, parallel.

TRANSITION CONTROL

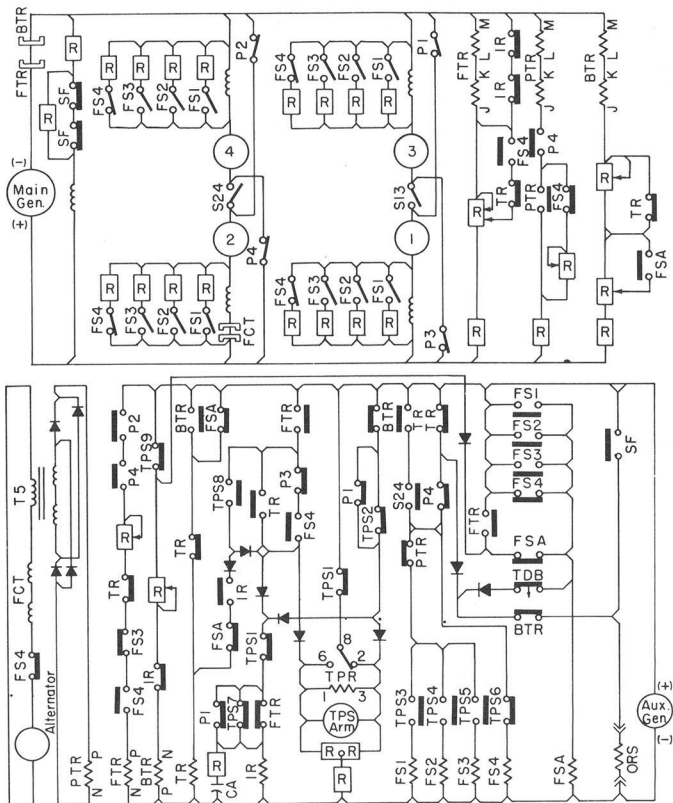

12126

Fig. 2-27 - Stepping Down - TPS1 Closes

In Fig. 2-28 BTR has picked up due to the 300 milliamperere control current in its N-P coil. BTR opening interrupted the circuit to the IR relay, but it is held picked up by energy stored in capacitor CA26.

The program switch motor armature now gets its energy through TPS1 and TPR 8-2 contacts, and it continues to rotate toward position 5.

TRANSITION CONTROL

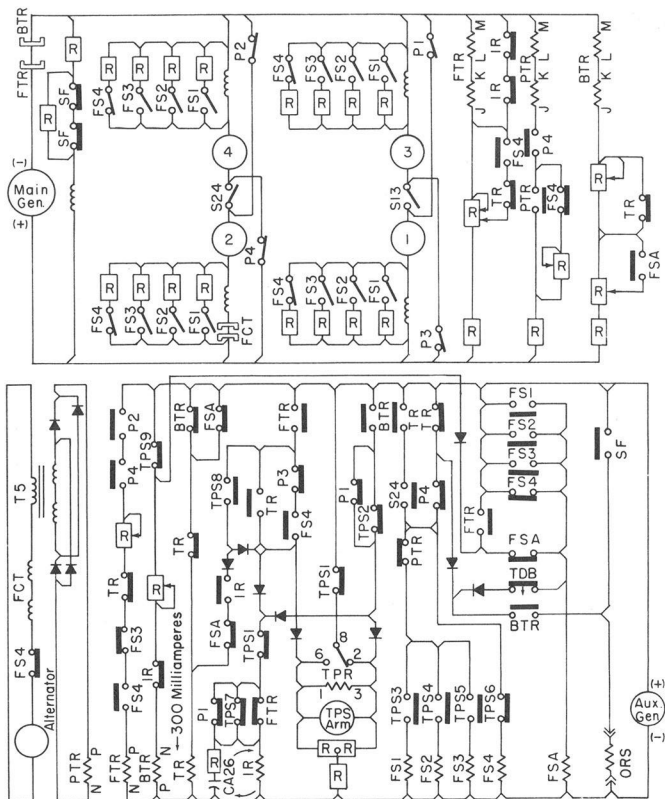

Fig. 2-28 — Stepping Down - BTR Pickup

12127

In Fig. 2-29 the program switch has moved approximately 25 degrees toward position 5.

TPS6 has opened and TPS5 has closed. As a result FS4 has dropped out and FS3 has picked up. The motor fields are shunted 51%.

The program switch continues to rotate toward the center of position 5.

TRANSITION CONTROL

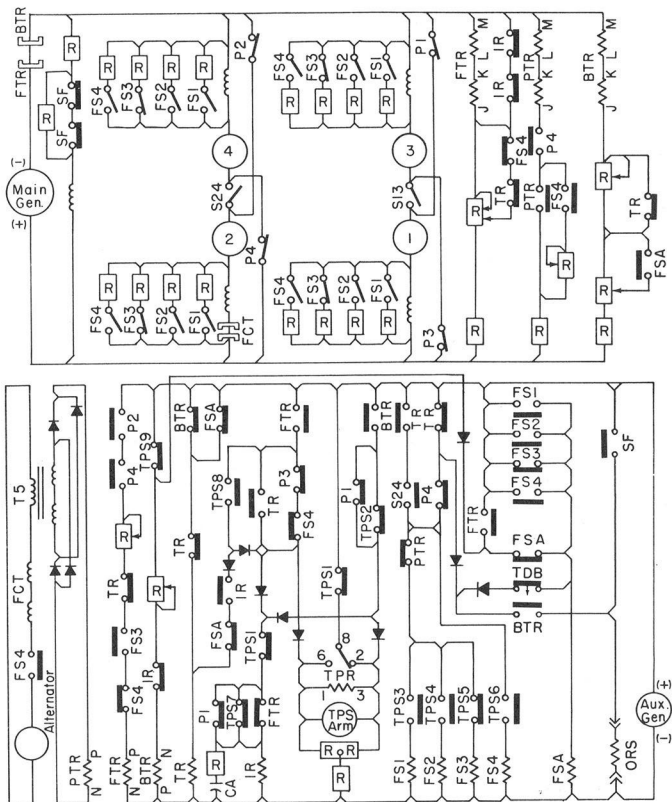

12128

Fig. 2-29 — Stepping Down - FS4 Out, FS3 In

TRANSITION CONTROL

In Fig. 2-30 the program switch has reached a point within 9 degrees of position 5. TPS1 opened, stopping the program switch abruptly.

TPR contacts 8 and 2 have opened.

TRANSITION CONTROL

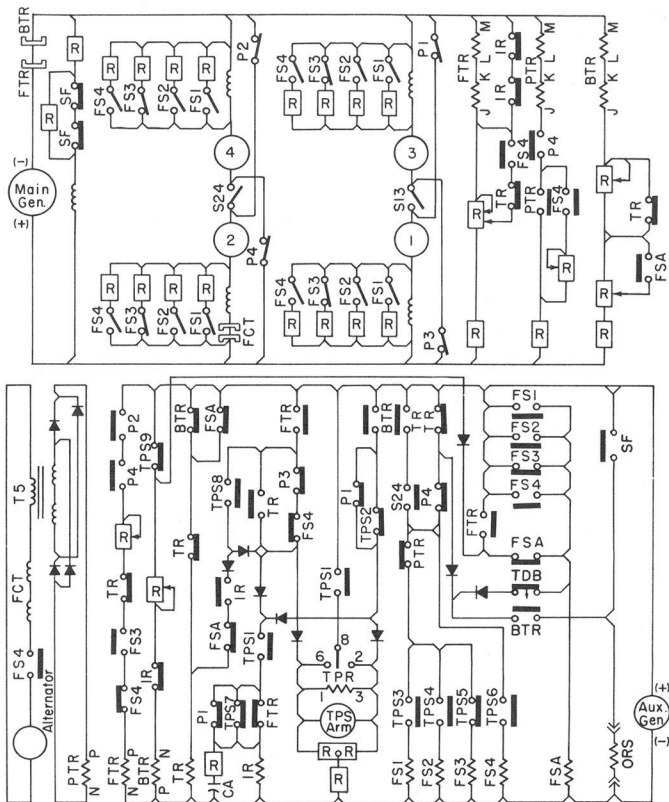

1 21 29

Fig. 2-30 — In Position 5 - IR Still Picked Up

TRANSITION CONTROL

In Fig. 2-31 one second has elapsed since TPS1 opened and the program switch stopped near the center of position 5.

IR has dropped out and BTR is held in by the system voltage which is now approximately 850 volts. Should the locomotive continue to decelerate due to the grade, the program switch will step down to the position corresponding to the balance speed of the locomotive on the hill.

Since the sequence of events in each step is identical to that occurring when going from position 6 to position 5, details are not shown here.

Should the grade lessen, the program switch is free to step back up to position 6 as dictated by the pickup of FTR.

Notice that the overriding solenoid in the engine governor will be energized each time BTR drops out. This reduces main generator excitation and provides smooth transition. However, during transition from full parallel to series-parallel motor connection, the overriding solenoid is energized by closed C-D contacts of shunt field contactor SF, and in addition the program switch normally steps down past position 10 and 9 into some lesser percentage of shunt. BTR E-F contacts being closed would keep ORS energized after SF contacts opened. As a result, the load regulator would be overdriven toward minimum field with a resulting loss of power. To prevent this the time delay relay TDB is energized when transition from full parallel to series-parallel occurs. The delayed

TRANSITION CONTROL

drop of TDB contacts prevents the load regulator from being overdriven.

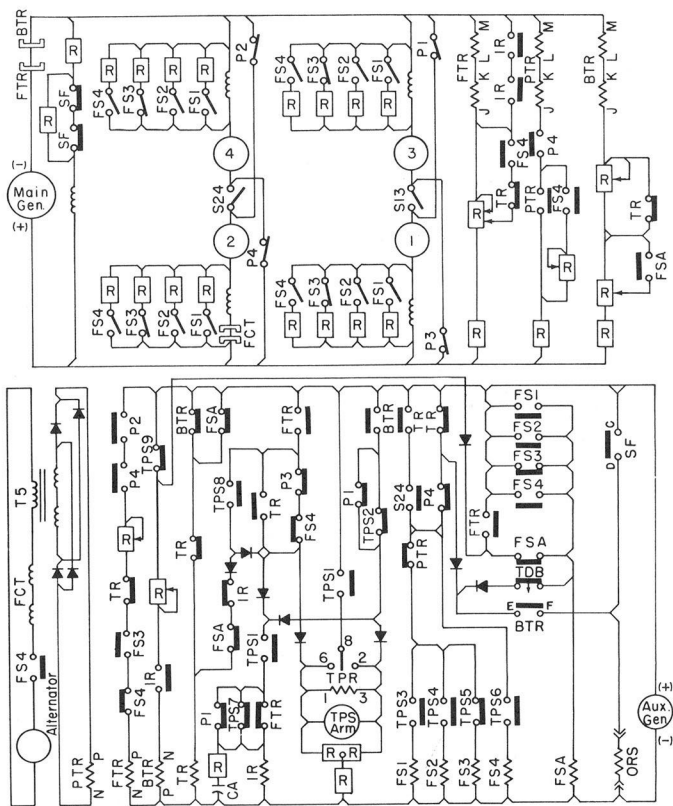

12130

Fig. 2-31 — In Position 5 Parallel, 51% Shunt



SECTION 3

DYNAMIC BRAKE CONTROL

In dynamic brake, the traction motors are reconnected as separately excited generators. The fields are connected in series across the main generator. The motor armatures are loaded on fixed grid resistors and the torque required to drive the armatures is derived from the motion of the train along the rails.

The armatures are connected in series with dynamic brake resistor grids. On the basic dynamic brake, two armatures are connected in series with two grids; on the extended range dynamic brake, four armatures are connected in series with four grids.

The GP35 uses 0.86 ohm loading resistance per motor. This load requires that the motor fields be excited with high current, and good ventilation is also required. The excitation system is capable of providing sufficient current with the engine at Idle speed, but the need for ventilation requires that the engine operate at Run 5 speed during dynamic braking.

Dynamic brake control consists of two main categories:

1. The manual control which the locomotive operator has over the amount of brake used.
2. Automatic armature current limit to protect the armatures and grids from overload.

The operation of these two phases of control is shown in detail on the following pages. The manual control will be explained first.

DYNAMIC BRAKE CONTROL

Fig. 3-1 shows the locomotive circuits connected for dynamic brake with the selector handle still in the "B" position. The sequence of going from power to brake is as follows: Throttle returned to IDLE and selector lever placed in "B" position. SF and BFA drop out; BR and SFT pick up. BR picking up interrupts the circuit to the series and parallel power contactors. When these drop out a circuit to BKB is completed. BKB picking up interrupts the circuit to the power brake contactors BKP1 and BKP2. Interlocks of BKP2 close to complete a circuit to BK and to series contactors S13 and S24.

The series contactors S13 and S24 are closed. The generator residual causes current to flow through the traction motor fields and the motor armatures develop current that flows through the dynamic braking grids. This residual current is held to a minimum by connecting the generator shunt field in reverse across the auxiliary generator. The current is limited by a resistor in the circuit to that required to buck the generator residual.

The brake relay has picked up to disconnect the load regulator arm from the No. 3 side of the PLR coil. The 24T wire is now connected to the No. 3 side of PLR. However, since the throttle switch has not been picked up, no voltage is applied to the 24T wire. The residual of the generator causes a signal from T3 to be applied to the No. 1 side of the PLR coil. PLR contacts move 8 - 6, and no energy is applied to the magnetic amplifier drive coils.

DYNAMIC BRAKE CONTROL

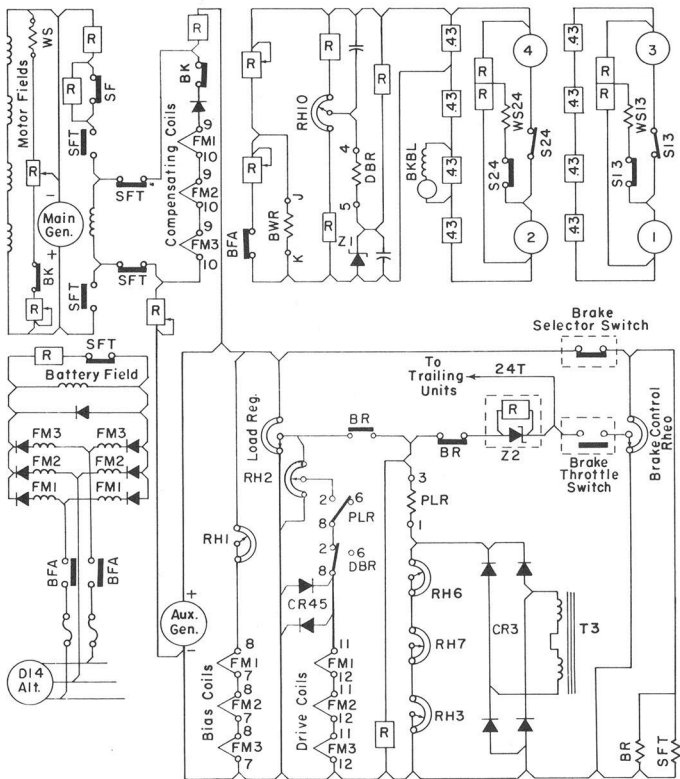

12131

Fig. 3-1 — Selector Lever In "B" Position

DYNAMIC BRAKE CONTROL

Fig. 3-2 shows the throttle handle moved from the idle position to a position corresponding to Run 1 in power. The 21T wire is energized and BFA and SF have picked up. SF picking up drops out ORS, causing the load regulator to move to maximum field position. SF has no other function except to open BFA with wheel slide in dynamic brakes.

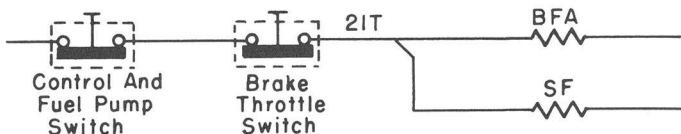

BFA, however, picking up connected the magnetic amplifier load windings to the D14 alternator. This would result in the 1.5 ampere minimum battery field current mentioned in conjunction with Fig. 1-6 in the excitation section of this handbook since the bias coils are still excited with 135-160 milliamperes.

The 1.5 amperes in the battery field is counteracted by the bucking current in the shunt field. This current is sufficient to hold armature current at a minimum of 200 amperes at top speed.

The load regulator is in maximum field position, but since the 24T wire is still at zero potential, PLR contacts are still closed 8-6 and the magnetic amplifier drive coils are not energized at this point.

The 10-9 compensating coils add stability to the control by compensating for current changes in the generator fields.

DYNAMIC BRAKE CONTROL

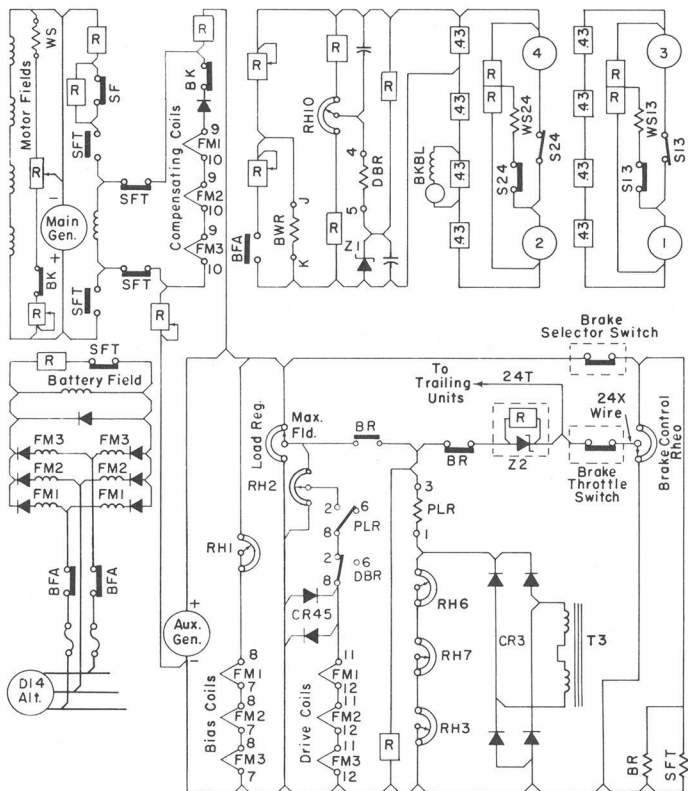

12132

Fig. 3-2 — In Minimum Brake Position

DYNAMIC BRAKE CONTROL

In Fig. 3-3 the operator has advanced the brake handle (throttle) sufficiently to cause a 10 volt potential on the 24-T trainline wire.

The 10 volts are applied at the dynamic brake zener, but since the zener does not conduct until 25 volts is applied, current flows through the zener resistor, and the resulting voltage at the No. 3 terminal of the PLR coil is a value less than 10 volts. The function of the zener diode is to provide a softer application of dynamic brakes when the brake (throttle) handle is moved slightly. This allows a train under certain conditions of train weight and track grade to maintain a desired high track speed while in dynamic braking.

When the signal from the 24T wire is higher than the feedback signal applied to the No. 1 terminal of the PLR coil, PLR contacts close 8 - 2 and current flows through the drive coils. Traction motor field current increases.

When traction motor field current increases, the feedback signal also increases to a value high enough to cause 8-2 contacts of PLR to open. The PLR 8-2 contacts oscillate between open and closed to regulate motor field strength.

Since this results in less voltage across the number 4 grid resistor than the DBR operating value, DBR does not operate. It is set to regulate at 700 amperes through the grids. DBR contacts remain closed 8 - 2. A reaction has taken place in the shunt field circuit which will be dealt with later.

DYNAMIC BRAKE CONTROL

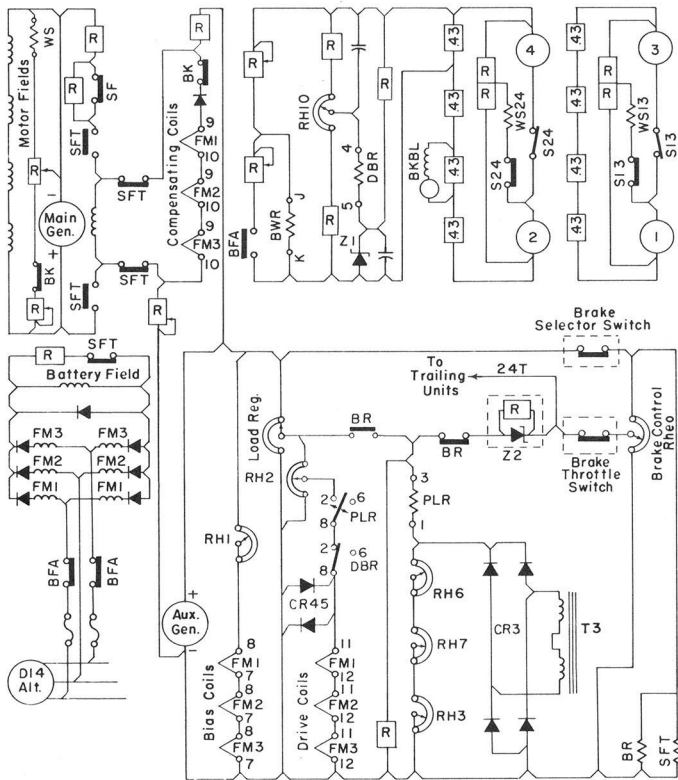

12133

Fig. 3-3 — Partial Brake - 30 MPH

DYNAMIC BRAKE CONTROL

After making sure that all train slack is bunched, the operator (conditions shown in Fig. 3-4) has moved the control handle slowly to the maximum brake position. This results in 50 volts applied to the number 3 terminal of the PLR coil. The battery field current increases proportionally until the motor field excitation reaches a level that results in 700 amperes armature current.

700 amperes armature current results in a voltage of $310 + 5$ across one resistor of the No. 4 grid. When this voltage is applied to the DBR circuit and RH10 is properly adjusted, 50 volts is applied to the zener diode Z1.

Z1 is constructed to maintain a 50 volt drop across the diode; that is, it will begin to conduct when 50 volts is applied. When Z1 conducts, current flows through the dynamic brake regulating DBR coil from 4 to 5 (about 100 ma). DBR contacts 8 - 2 open, and energy is removed from the magnetic amplifier drive coils. Battery field excitation decays, and braking current drops.

When braking current drops below 700 amperes, less than 50 volts is applied to Z1, and Z1 blocks. DBR contacts 8 - 2 close when no current flows through the coil. DBR contacts closing energizes the magnetic amplifier drive coils. DBR contacts oscillate between open and closed to regulate motor field strength at 700 amperes.

The condensers in the DBR circuit provide anticipation and smooth out voltage peaks, resulting in a smoother operating regulator.

DYNAMIC BRAKE CONTROL

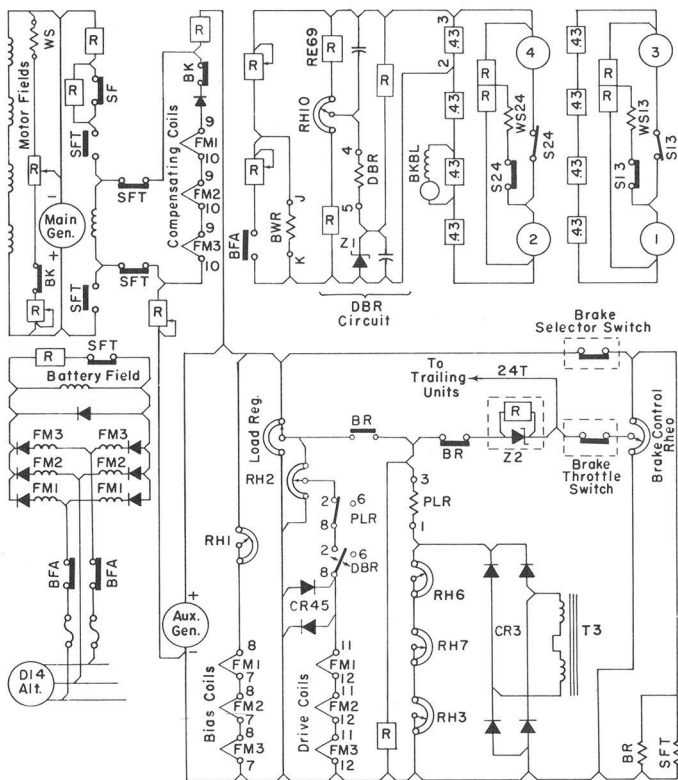

12134

Fig. 3-4 — Full Brake - 30 MPH

DYNAMIC BRAKE CONTROL

When DBR is functioning, braking current will not exceed 700 amperes; however, a brake warning circuit is provided to protect against possible excess braking current.

The brake warning relay BWR will pick up when braking current results in a voltage of 335 ± 5 across the No. 2 and No. 3 terminals of the No. 4 braking resistor grid. When BWR picks up, the circuit to BFA is interrupted and BFA contacts drop. This removes excitation from the main generator battery field, causing a reduction in braking current.

The E-F contacts of BFA close to insert RE61A across the BWR coil. This recalibrates BWR dropout to 290 ± 10 volts. At that voltage across the No. 2 and 3 terminals of grid No. 4, braking current is less than 700 amperes. BFA again picks up, energizing the battery field.

Modulation of battery field current causes a reaction to take place in the shunt field. This is explained in the following text.

DYNAMIC BRAKE CONTROL

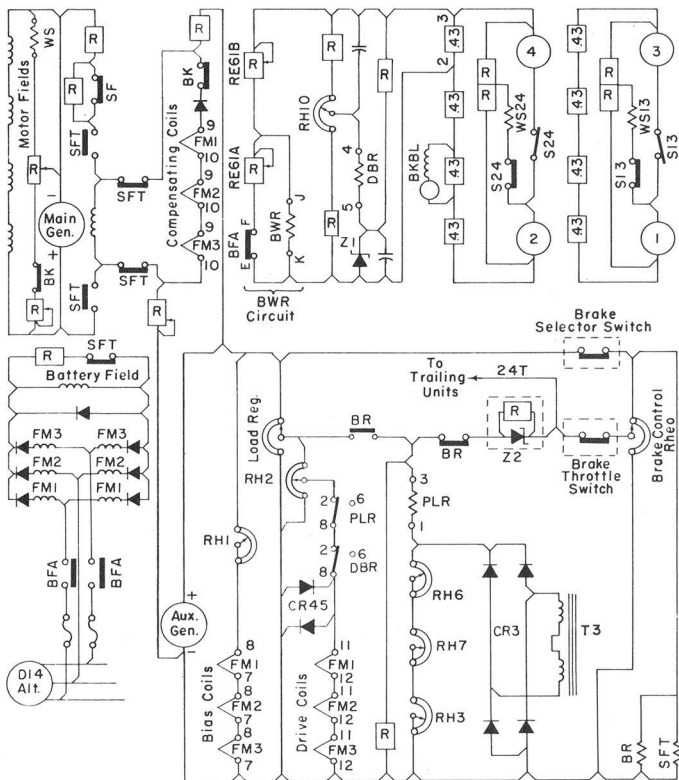

12135

Fig. 3-5 — Braking In Excess Of 700 Amperes

Modulation of battery field current occurs normally under four conditions:

1. PLR operation
2. DBR operation
3. BWR operation
4. Wheel slip action

Each of these conditions causes a change in the excitation level of the main generator battery field. Assume that either PLR, DBR, or BFA contacts close after having opened to decrease battery field excitation. A good portion of the D14 alternator voltage is then impressed upon the battery field. As current begins to flow in the battery field a back voltage is built up not only in the battery field, but by transformer action in the shunt field as well. The polarity of the induced voltage is indicated on Fig. 3-6 by arrowheads in the circuit involved.

The voltage induced in the shunt field causes a current to flow in a third reactor winding 10-9, and this current opposes the current in the 11-12 drive coils and increases the impedance of the reactors. This, of course, limits the flow of current in the battery field to stabilize system response to rapid changes in battery field current.

This compensating effect is weaker than the drive signal, so the net result is a slow buildup of current in the battery field. Thus the buildup of current in the battery field, therefore in the motor fields and the motor armatures, is slowed by the reactor compensating winding.

DYNAMIC BRAKE CONTROL

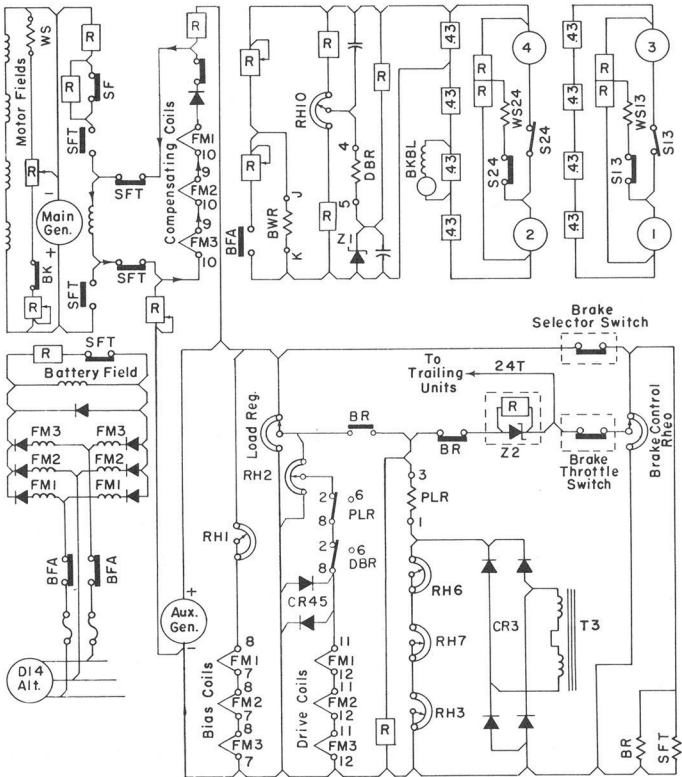

12136

**Fig. 3-6 — Compensation After PLR, DBR,
Or BFA Closure**

DYNAMIC BRAKE CONTROL

In Fig. 3-7 assume again that either PLR, DBR, or BFA contacts close after having opened to decrease battery field excitation current. The compensation effect shown in Fig. 3-6 takes place, but an additional action occurs to insure stable regulation of dynamic braking current at 700 amperes.

As motor armature current rises, the voltage drop across the No. 2 and No. 3 terminals of grid No. 4 also rises. This rising voltage charges the capacitors connected in parallel with RE69 and Z1. The charging current, together with resistor current, results in a prematurely high DBR coil current. This causes DBR to pick up to prevent a system overshoot, interrupting current to the magnetic amplifier drive coils and limiting battery field excitation.

As the capacitors become charged, the charging current no longer appears in the DBR coil. Coil current is then dependent upon zener current. Thus the operating point of DBR rises to 700 amperes as the capacitors become charged. At 700 amperes Z1 conducts and DBR will pick up on current through RE69 and RH10.

This anticipation effect, together with the compensation effect results in very stable DBR function with little or no overshoot. These effects take place during normal operation as well as during wheel slide recovery or accidental mishandling by the locomotive operator.

DYNAMIC BRAKE CONTROL

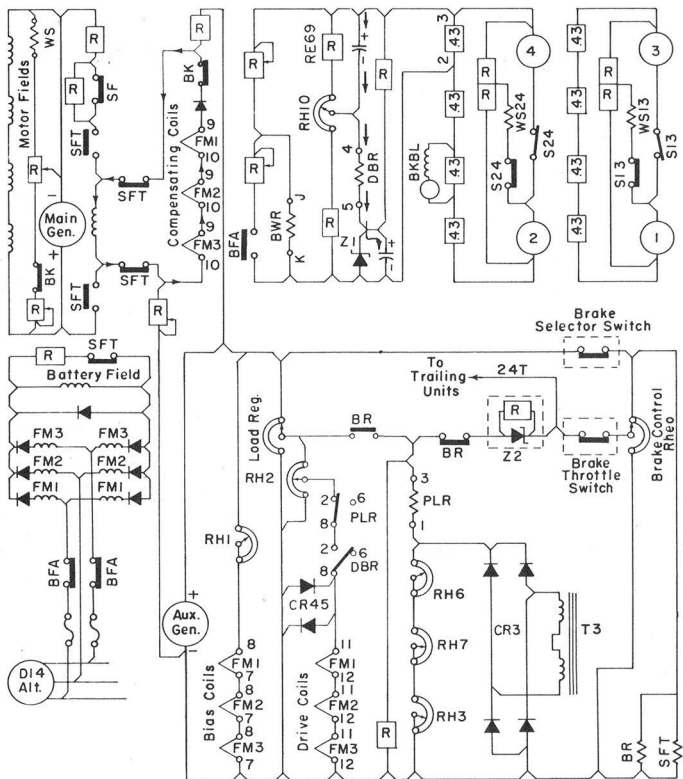

12137

Fig. 3-7 — Anticipation Effect

DYNAMIC BRAKE CONTROL

During dynamic braking, the C-D coil of wheel slip relay WS is connected across the traction motor fields. If the motor fields become hot because of excessive motor field current, main generator voltage becomes high enough to bring about pickup of wheel slip relay WS, and generator excitation is reduced by dropout of BFA.

DYNAMIC BRAKE CONTROL

Motor Field Protection

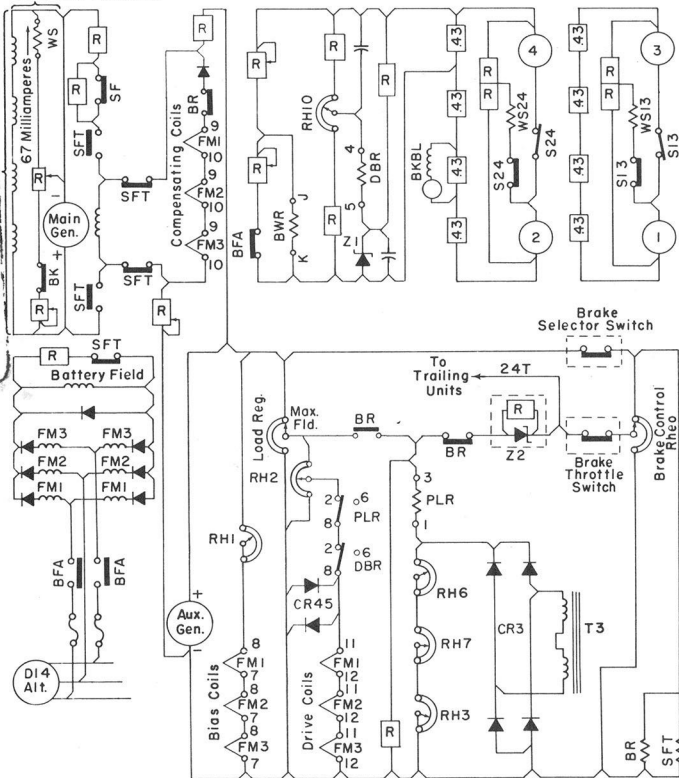

12120

Fig. 3-8 — Excessive Motor Field Current

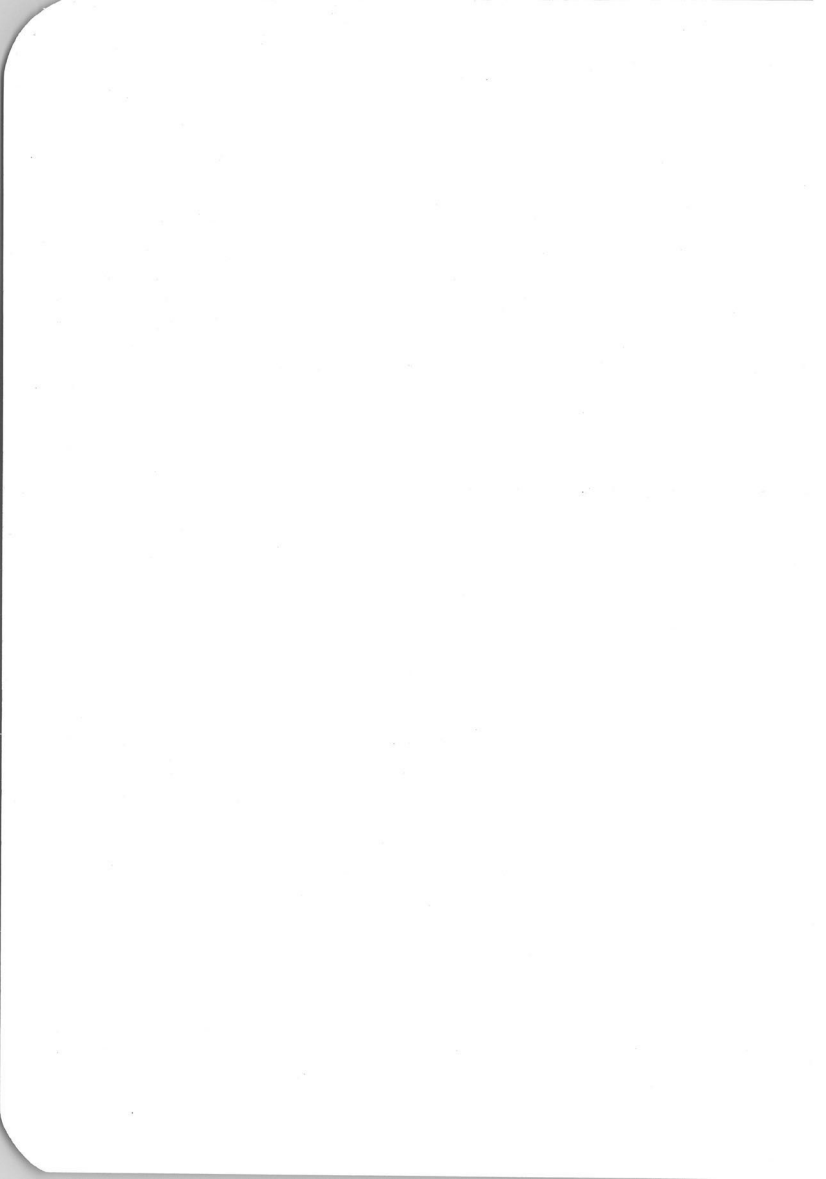

SECTION 4

TROUBLE SHOOTING

Fig. 4-1 shows the recommended method of checking the excitation reactors. The test closely approximates actual locomotive operating conditions.

The reactors may also be checked for shorted turns. Since reactors are basically transformers, an alternating current in any one winding will be reflected in all remaining windings unless they are open or shorted.

A handy AC source is found at the coil of the NVR relay, provided the engine is running. With the engine idling, a 100-150 watt 110 volt test light can be connected in series with, for example, the 1-2 reactor winding. An AC voltmeter can then be used to check the induced voltages in the remaining windings.

If the voltage across 1-2 is 20 volts, then 7 - 8 should be 47 volts, 9 - 10 should be 118 volts, etc. These values will vary somewhat due to the load imposed by the meter used, but absolute values are not necessary.

TROUBLE SHOOTING

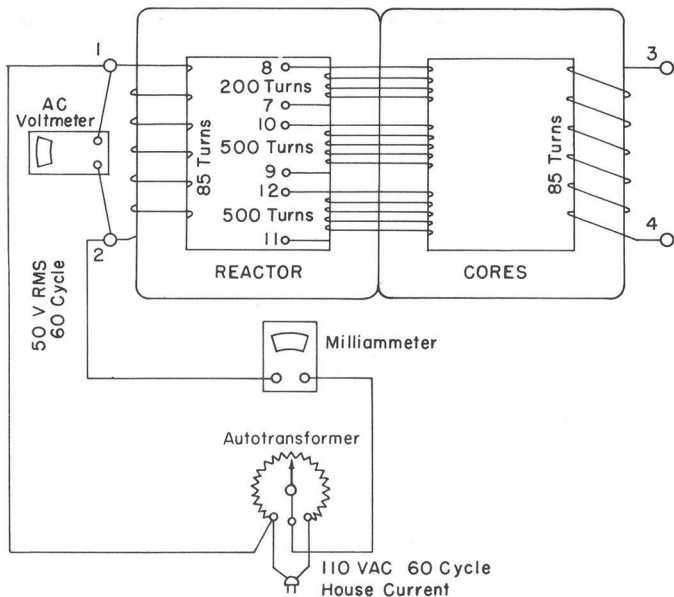

12138

Apply 50 RMS 60 cycle volts to the 1-2 coil; Repeat with the 3-4 coil.

Add the two milliamperere readings. The sum must not exceed 750 milliamperes.

Fig. 4-1 — Reactor Check Circuit

The reactors should be disconnected and the BFA contactor kept open during the checks. Notice that the 3 to 4 winding is not on a common core with the 1 to 2 winding; therefore, if all windings are disconnected and no load is imposed, no voltage will appear at the 3 to 4 winding.

A shorted turn will result in zero or near zero voltage from 1-2, hence all other windings will show a similar lack of voltage.

The resistance to ground can be checked with a megger in the conventional manner.

Open windings can be checked with any good ohmmeter.

Fig. 4-2 shows suggested methods of checking excitation and feedback rectifiers.

The engine need not be running for the rectifier check. The reactor load windings should be disconnected as shown in order to prevent parallel resistance paths.

With BFA open, an ohmmeter should show a high resistance reading when the negative lead is on the positive side of the rectifier, and a low reading when it is on the negative side. A low reading on the ohmmeter when the positive lead is on the negative (red) side of the rectifier indicates a shorted or bad order rectifier.

TROUBLE SHOOTING

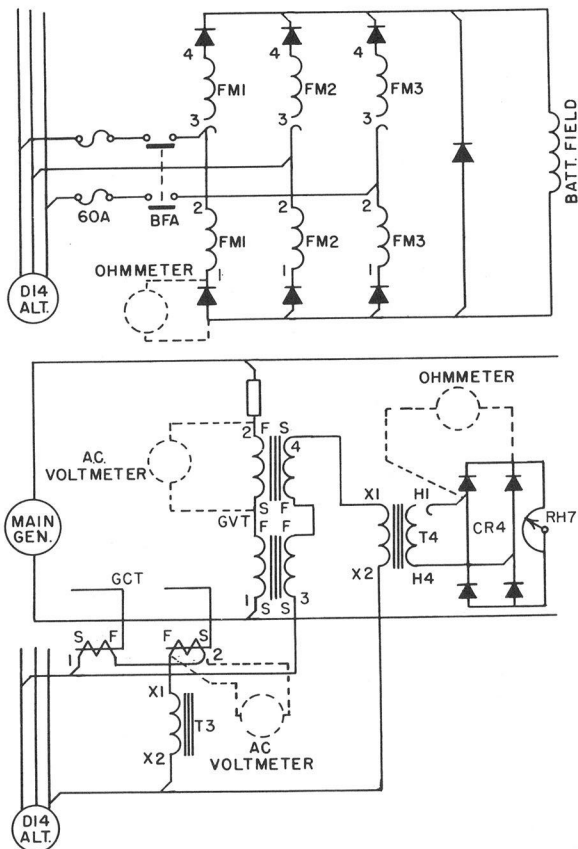

12139

Fig. 4-2 — Rectifier-Reactoer Checking

With the engine at idle, the feedback reactors can be checked for shorted turns by reading the AC voltage drop across the various windings as shown in Fig. 4-2. In the case of the voltage transductor GVT and current transductor GCT, a shorted turn in any one winding will result in unusually low voltages at all windings on that reactor.

Fig. 4-3 shows the recommended current leakage test for the generator current transductor GCT and for the generator voltage transductor GVT.

As with the excitation reactors, the insulation of the various windings to ground can be checked with a megger. The windings can be checked for opens with an ohmmeter.

T3 and T4 are conventional 1 to 4 ratio transformers and can be checked in a manner identical to that used for the reactors.

TROUBLE SHOOTING

For GCT test apply 100 volts RMS 60 cycle to coil terminals 1 and 2. Current in the coils should not exceed 0.030 amperes.

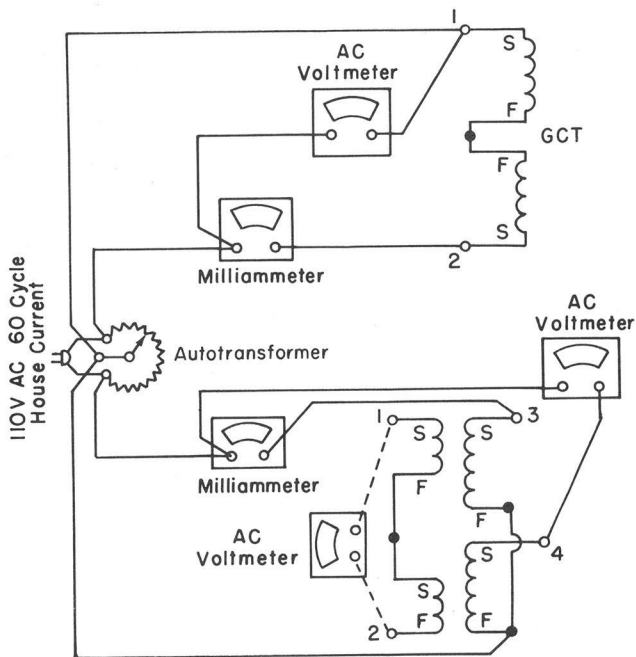

12351

For GVT test:

1. Apply 100 volts RMS 60 cycles to coil terminals 3 and 4. Current in the coils should not exceed 0.0135 amperes.
2. Apply 100 volts RMS 60 cycles to coil terminals 3 and 4. Voltage across coil terminals 1 and 2 should be a maximum of 0.3 volt.

Fig. 4-3 — Current Leakage Test

TROUBLE SHOOTING

Fig. 4-4 graphically illustrates PLR relay operation. Since the main generator does not operate above 1,000 volts, the operation lines are cut off at that point.

The two lines that are anchored at 2,550 amperes indicate the high and low tolerances between which the PLR relay should operate when the locomotive travels at speeds between 18.5 and 12 MPH (62:15 gear ratio). The bend at approximately 700 volts and 2,000 amperes occurs at a speed of 12 MPH. The lines indicate tolerances between which PLR will operate at speeds less than 12 MPH.

The lines anchored at 3,600 amperes indicate tolerances between which PLR should operate at speeds between 18.5 and 30 MPH. The speeds are approximate and will vary with motor temperature. In parallel motor connection (above 30 MPH) PLR is used only as an aid in snubbing transient overloads such as those due to motor field shunting or wheel slip.

In the lower portion of Fig. 4-3, the vertical line at 975 amperes indicates the maximum main generator amperes that PLR will allow during dynamic braking. It should be remembered that during braking, PLR will operate at variable lower amperages dependent upon the signal from the brake control rheostat.

TROUBLE SHOOTING

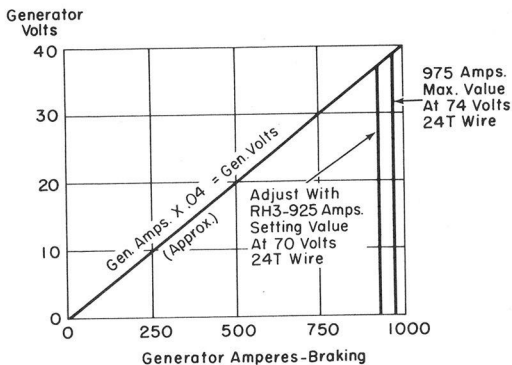
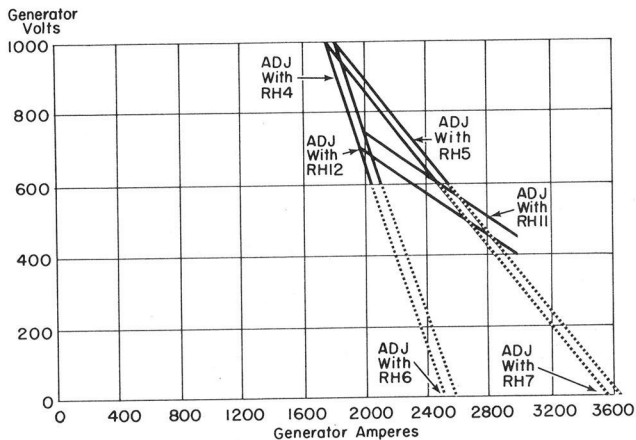

12140

Fig. 4-4 — Power Control Adjustment Graph

Every conceivable precaution against failure has been taken in the design of the components and circuitry in the GP35 transition control. Transition relays FTR, BTR, and PTR have proved very reliable in years of service. The program switch also has been thoroughly field tested. Maximum reliability of the various switches used is accomplished by paralleling their contacts, and the circuitry directly involved with program switch operation includes numerous safeguards against faulty operation.

Fig. 4-5 illustrates the general procedure to be used in troubleshooting and checking the transition circuits. Notice that isolation switch and engine run relay contacts are shown at the "step-down" side of the feed to the transition program switch. A loading shunt is shown short circuiting the main generator. This arrangement is used to check the operation of transition relays FTR and BTR. The loading shunt is removed when current is to be directed through the No. 2 motor field in order to check operation to PTR.

TROUBLE SHOOTING

Should transition trouble occur, the suggestions offered in the following articles may be helpful in finding the cause of the trouble.

TRANSITION CYCLING

1. Failure of the circuit to the BTR N-P coil. With the IR relay picked up and TPS9 A-B contacts closed, 300 milliamperes should flow in the N-P coil at 74 volts, and BTR should pick up.
2. Failure of FTR P-N coil circuit. With P2, P4, TR, FS3, and FS4 contacts closed, approximately 94 milliamperes should flow in the FTR P-N coil at 74 volts with the P side of the coil positive.
3. Lack of motor field shunt. Perform a program switch sequence check. This may be done by using an MG set connected at the test jacks to step up the program switch. With the isolation switch in RUN position and the engine run switch in the OFF position, MG set voltage should then be reduced. The program switch may then be stepped one step at a time by momentarily placing the engine run switch in the ON position.
4. Lack of dropout delay on the IR relay. This relay should drop out approximately 1 second after it has been de-energized. Loss of time indicates bad order CA26 or RE40.

TROUBLE SHOOTING

5. Faulty calibration of limiting resistors in the circuits to the FTR or BTR operating coils. Brackets are provided on which a load shunt can be fastened to short circuit the main generator. Operation of FTR and BTR can thus be checked at various main generator currents while an MG set applies voltage to the operating coils.
6. Faulty calibration of limiting resistors in the circuit to the PTR operating coils. A low current value through the No. 2 traction motor field is necessary to check calibration of PTR resistors. This current may be obtained with the locomotive brakes set to prevent movement, or with the controls set up for dynamic braking if the locomotive is so equipped. An MG set will apply voltage to the operating coils.

FAILURE TO MAKE TRANSITION

1. If the unit loads properly in transition position No. 1, make a program switch sequence check, using an MG set. This will check circuit continuity through limiting resistors and transition relays. Operation of FS contactors, TR relay, and power contactors can be checked during the sequence check.
2. If the program switch sequences properly and contactor operation is satisfactory, check operation of transition relays as described in steps 5 and 6 above.

TROUBLE SHOOTING

Fig. 4-6 shows the general procedure to be used in testing and setting the performance control circuits. Space prohibits presentation of a complete diagram and instructions on setting and testing, but the diagram should provide some idea of the procedure required for testing.

TROUBLE SHOOTING

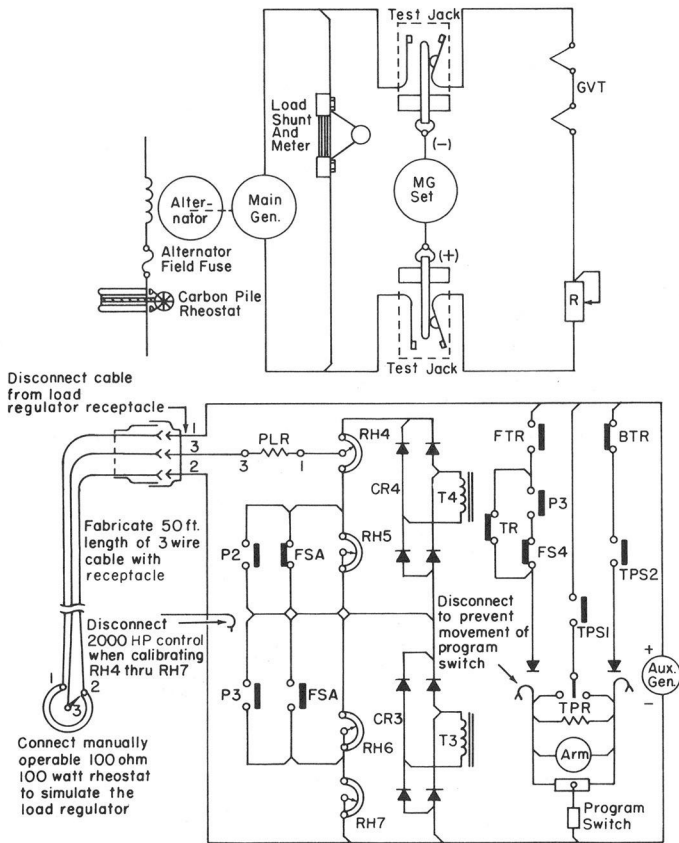

12142

Fig. 4-6 — Performance Control Circuit Calibration

TROUBLE SHOOTING

Fig. 4-7 shows the various adjustments required for the GP35 dynamic brake control. Once properly set, these adjustments should not be changed. When trouble is encountered, circuitry should be checked before an attempt is made to change the adjustments.

DBR operation can be checked by connecting an MG set input across the main generator, and by connecting the MG set output across the resistor, coil, and zener diode in the brake regulator circuit. With the controls set up for dynamic braking and proper jumpers applied, operating of the brake control lever (throttle) will excite the main generator, but DBR will regulate at a voltage corresponding to 700 amperes dynamic braking current. When DBR operation is checked, several seconds should be allowed for the capacitors in the circuit to become fully charged. RH10 is adjusted to obtain regulation at 700 amperes dynamic braking current.

BWR operation can be checked by connecting an MG set input across the battery and adjusting the resistors in the BWR circuit for correct pickup and dropout of BWR.

Motor field protection is obtained by adjusting a 100 ohm resistor for WS pickup when 55 volts appears across the traction motor fields.

TROUBLE SHOOTING

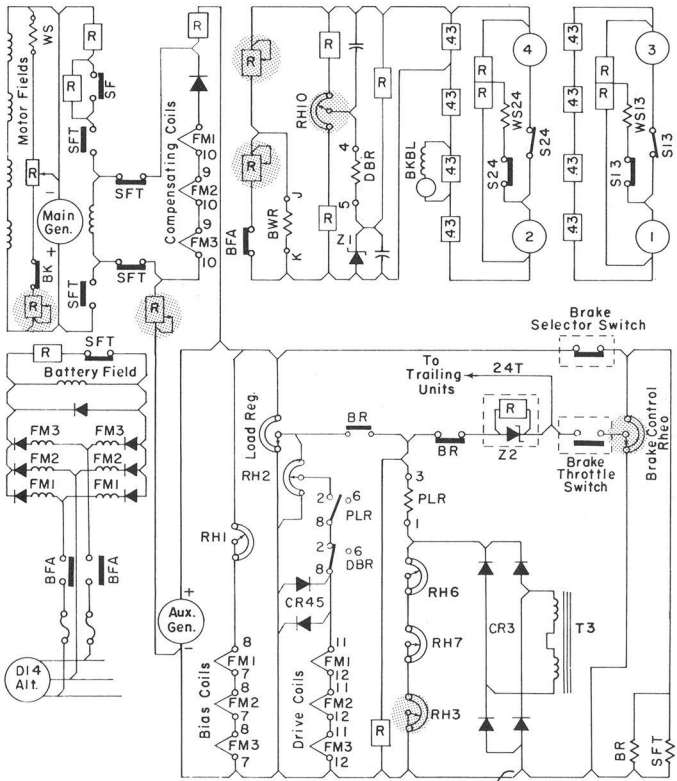

12143

Fig. 4-7 — Dynamic Brake Control Circuits

TROUBLE SHOOTING

As the brake control handle is moved toward maximum brake position, the voltage drop across the zener resistor RE1 increases from 0 to 25 volts as voltage on the 24T wire is increased from 0 to 50 volts. When the voltage drop across the zener resistor RE1 equals the holding voltage of the 25 volt zener diode, the zener resistor RE1 is no longer effective, and the drop across Z2 remains at a constant 25 volts while the drop across RE2 increases with an increase in applied voltage, see Fig. 4-8.

The current in the magnetic amplifier drive coils varies with the time "on" in relation to the time "off" of PLR contacts. This relationship, in conjunction with the decay of the battery field through the rectifier in parallel with the field results in battery field current that is essentially constant and proportional to the potential on the 24B wire. At maximum brake handle position, battery field current should be about 15 amperes.

The reactor bias current should be 135-160 milliamperes at 74 volts. The reactor drive coil current should be approximately 65 milliamperes at 74 volts.

The following are a few aids in trouble shooting the dynamic brake control.

TROUBLE SHOOTING

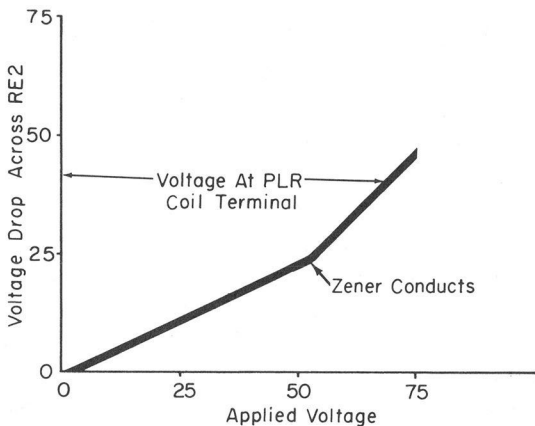
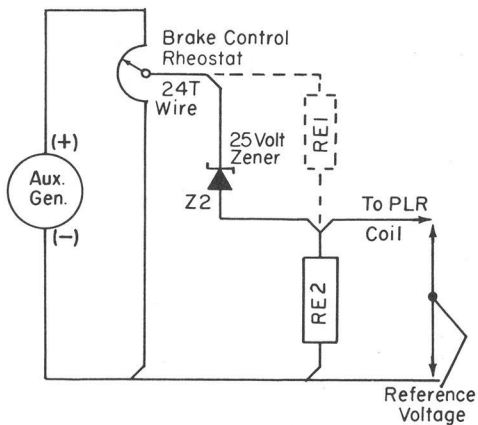

12144

Fig. 4-8 — Dynamic Brake Zener Characteristics

TROUBLE SHOOTING

LACK OF MOTOR FIELD CURRENT

1. Check voltage at the 24T wire. Loss of voltage indicates a tripped control breaker or faulty brake control rheostat.
2. Check reactor 11-12 drive coil current.
3. Failure of the BK contactor to close. Check circuit to this contactor.
4. BFA fuses missing or blown. If blown, check condition of reactors and rectifiers as suggested in the text adjacent to Figs. 4-1, 4-2, and 4-3.
5. Check main generator voltage as shown in Fig. 4-4.

EXCESSIVE MOTOR FIELD CURRENT

1. Check for loss of reactor bias coil current.
2. Check for shorted rectifier in the compensation coil circuit.
3. Check PLR operation, and setting of RH3.

BRAKE WARNING RELAY ACTION

1. Check for loss of reactor bias coil current.
2. Check for excessive reactor drive coil current.
3. Check DBR operation as previously described.
4. Check for shorted rectifier in the compensation coil circuit.
5. Check pickup of BWR with an MG set. Allow at least 5 minutes at 1000 volts to heat the relay coil and resistor. Check against the values indicated on the locomotive wiring diagram.

