

Sept. 25, 1928.

1,685,097

R. J. SCHEIBLI, JR

JOURNAL BOX LID

Filed July 28, 1926

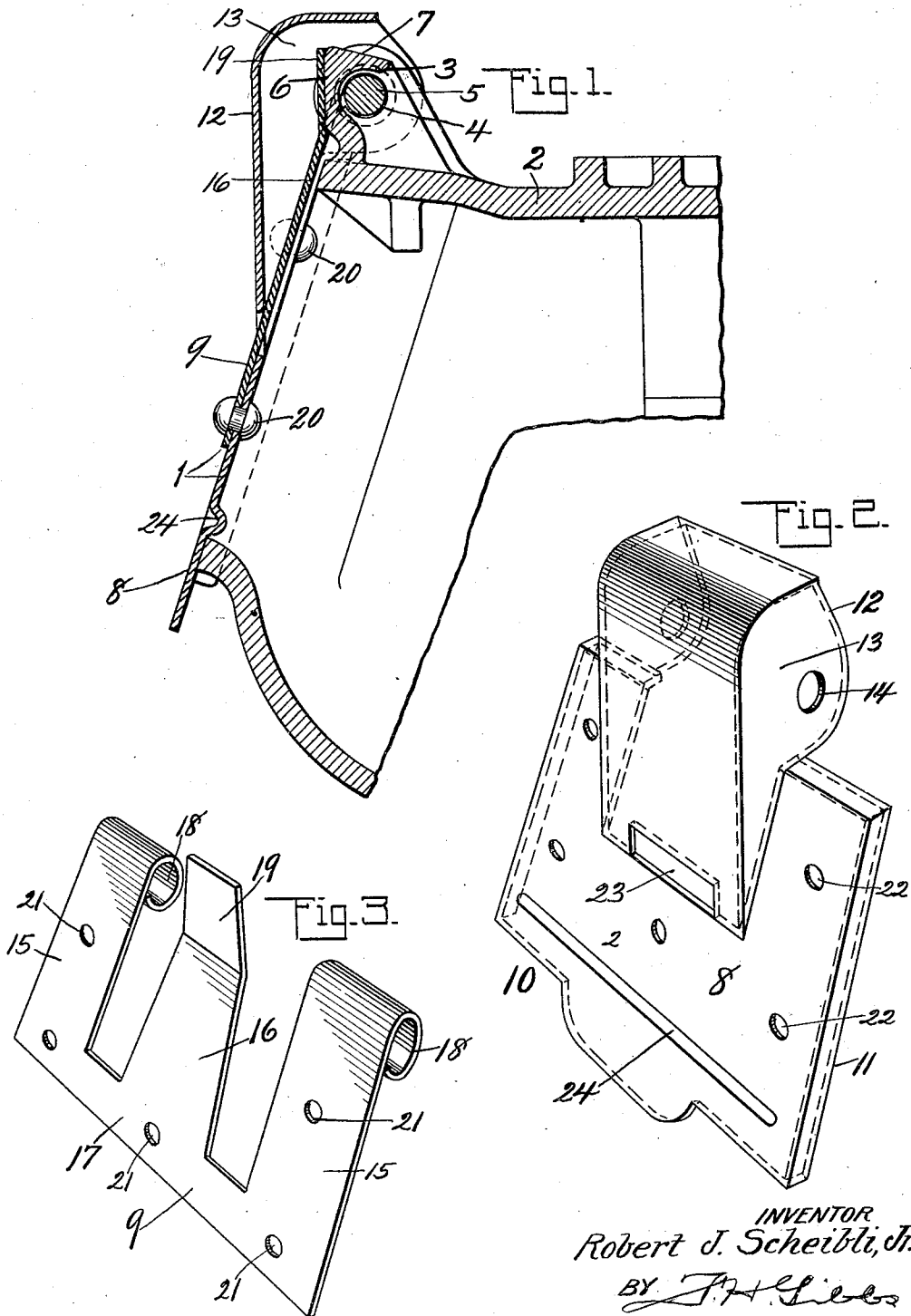

INVENTOR
Robert J. Scheibli, Jr.
BY *J. H. Silles*
ATTORNEY

UNITED STATES PATENT OFFICE.

ROBERT J. SCHEIBLI, JR., OF ST. LOUIS, MISSOURI, ASSIGNOR TO AMERICAN CAR AND
FOUNDRY COMPANY, OF NEW YORK, N. Y., A CORPORATION OF NEW JERSEY.

JOURNAL-BOX LID.

Application filed July 28, 1926. Serial No. 125,448.

Reference is had to the accompanying drawings, which illustrate the preferred form of the invention, though it is to be understood that the invention is not limited to the exact details of construction shown and described, as it is obvious that various modifications thereof within the scope of the claims will occur to persons skilled in the art.

10 In said drawings:

Fig. 1 is a partial central vertical section of a journal box provided with a lid constructed in accordance with this invention;

15 Fig. 2 is a perspective view of the pressed body portion of the lid; and

Fig. 3 is a perspective view of spring and reinforcing plate portion of the lid.

This invention relates to lids for journal boxes and it is an object of this invention to provide an improved lid comprising a pressed metal body portion and a reinforcing plate of spring metal which will provide bearings for the hinge pin and a retaining spring. It is also an object of this invention to provide a lid of the type described which is durable and efficient in service and which may be readily manufactured and applied.

20 In the drawings the lid 1 is shown applied to a journal box 2 having a lug 3 provided with openings 4 to receive the hinge pin 5 which secures the lid 1 to the journal box 2. The lug 3 is also provided with flat angularly disposed surfaces 6 and 7 against which the retaining spring of the lid engages to hold the lid in the closed and open positions, respectively.

25 The lid 1 comprises a body portion 8 and a spring plate 9, the body portion 8 being formed as a flat substantially rectangular member 10 having flanges 11 at its edges, a stiffening corrugation 24 and a hood 12 pressed outwardly from the member 10. The hood 12 extends beyond an edge of the remainder of the body portion of the lid and is provided with parallel sides 13 having openings 14 which receive the pin 5. The spring plate 9 is substantially E-shape having end members 15 and a central member 16 joined by a back member 17, the end members having their ends rolled to form openings 18 which receive the pin 5 while the central member is bent slightly at its end as at 19 to contact with the faces 6 and 7 of the lug 3 and act as a retaining spring

and is tapered upwardly from the back member 17 to provide additional resiliency. The spring plate 9 is applied to the outside of the body portion 8 and secured thereto in any suitable manner as by welding or by rivets 20 inserted in the holes 21 and 22 in the spring plate 9 and body portion 8, respectively, the central member 16 being inserted through an opening 23 in the hood 12 so as to contact with the lug 3 and the end members extending on opposite sides of the hood 12 with their openings 18 in line with the openings 14 of the hood so that the lid may be readily applied by placing it with the hood 12 over the lug 3 and the openings 18 and 14 in line with the opening 4 of the lug 3 to receive the pin 5.

Forming the retaining spring 16 and hinge portions 15 as shown provides a member which reinforces the box lid, positively positions the retaining spring with respect to the hinges and provides a means for readily securing the retaining spring to the body portion of the lid.

What is claimed is:

1. In combination, a casing open at one end, a pivotally supported closure therefor, and a resilient plate of substantially the same width as the closure secured thereto and having attaching portions extending adjacent the sides of the closure and a free resilient tongue intermediate the attaching portions and bearing against a fixed abutment adjacent the pivoted end of the closure whereby to exert a uniform pressure on the closure for substantially the entire width thereof.

2. The combination with a journal box having a pivoted closure, of a resilient plate extending entirely across the pivoted closure and attached thereto, and having hinge elements at one end engaged by the pivot pin for the closure, and a free intermediate resilient tongue passing upwardly through the closure and engaged with a fixed abutment on the journal box, such resilient plate functioning to retain the closure in either closed or open position.

3. In a journal box, a lid comprising a body portion having a hood formed there-with and a retaining spring having a portion thereof projecting beneath the hood, said spring being of substantially the same width as the lid whereby to exert pressure on the lid throughout substantially the entire width

thereof to cause said lid to firmly seat on the journal box for substantially the entire area thereof, and hinge elements carried by the spring and secured to the journal box on each side of the hood.

4. In combination with a casing, a closure therefor, mounting means intermediate the sides of the closure for supporting the same, and resilient means secured to the closure and having attaching portions extending on each side of the before-mentioned mounting means and a tongue intermediate the attaching portions, said tongue engaging the fixed abutment on the casing whereby to retain the closure in open or closed position.

5. In combination with a casing having a hinge pin secured thereto, a closure for the casing having an attaching element intermediate its side edges for engagement by said hinge pin, means secured to the closure

and provided with attaching portions arranged on each side of the attaching element and engaging said pin, said means also having a resilient member intermediate the attaching portions bearing against a fixed abutment on the casing for retaining the closure in open or closed position.

6. In a journal box, a lid having a body portion and attaching means intermediate its side edges for supporting the same, a retaining plate extending from side to side of the lid and secured thereto and having supporting hinge elements arranged on each side of the before-mentioned lid attaching means, and a spring element intermediate the hinge elements for retaining said lid in open or closed position.

In witness whereof I have hereunto set my hand.

ROBERT J. SCHEIBLI, JR.