

April 1, 1924:

1,488,659

J. C. ABEL ET AL

WALK OVER SEAT

Filed Feb. 5, 1921

3 Sheets-Sheet 1

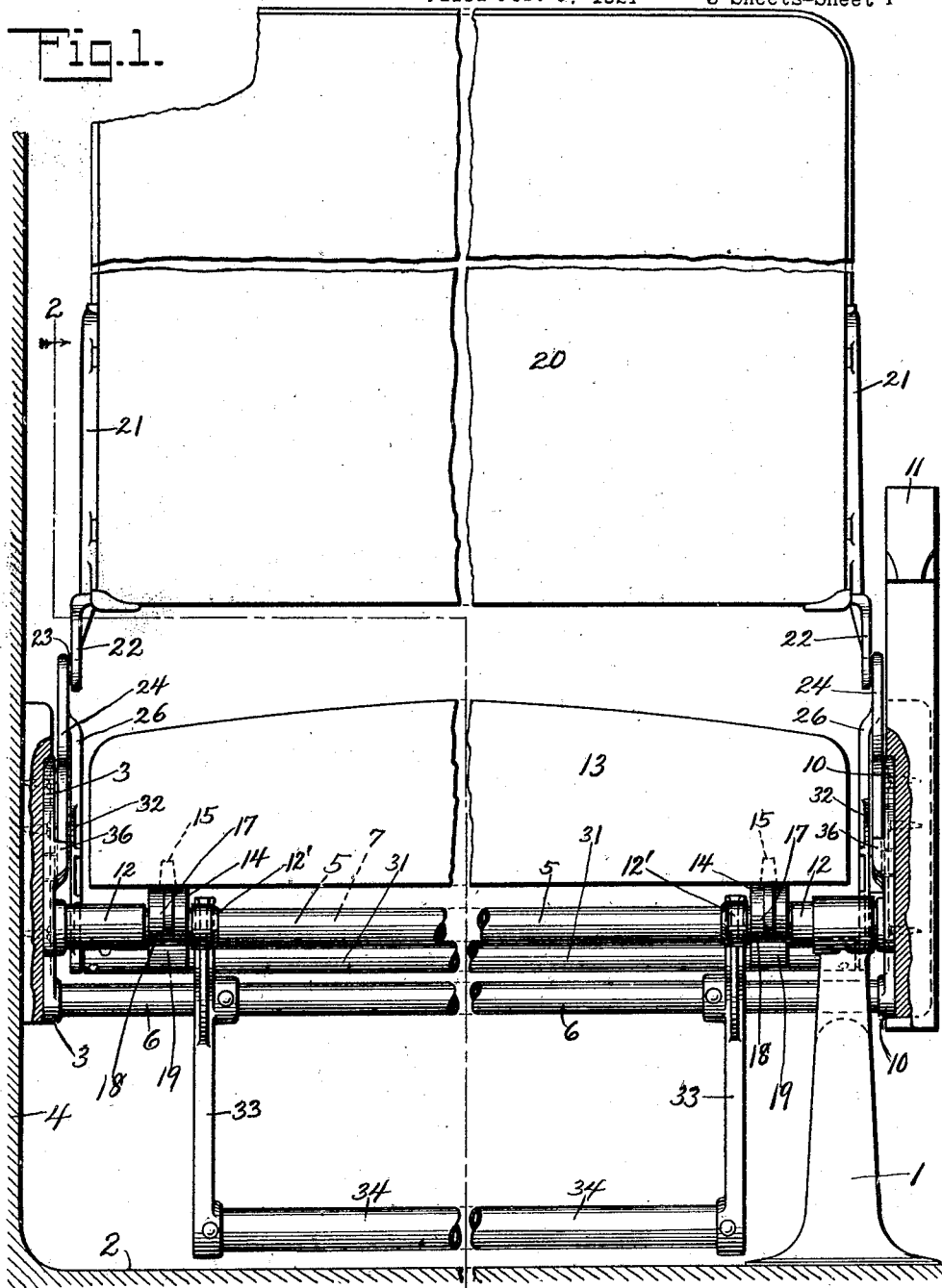

INVENTORS:
Joseph C. Abel
and Victor Willoughby
BY *J. H. Gies*
ATTORNEY.

April 1, 1924.

1,488,659

J. C. ABEL ET AL

WALK OVER SEAT

Filed Feb. 5, 1921

3 Sheets-Sheet 2

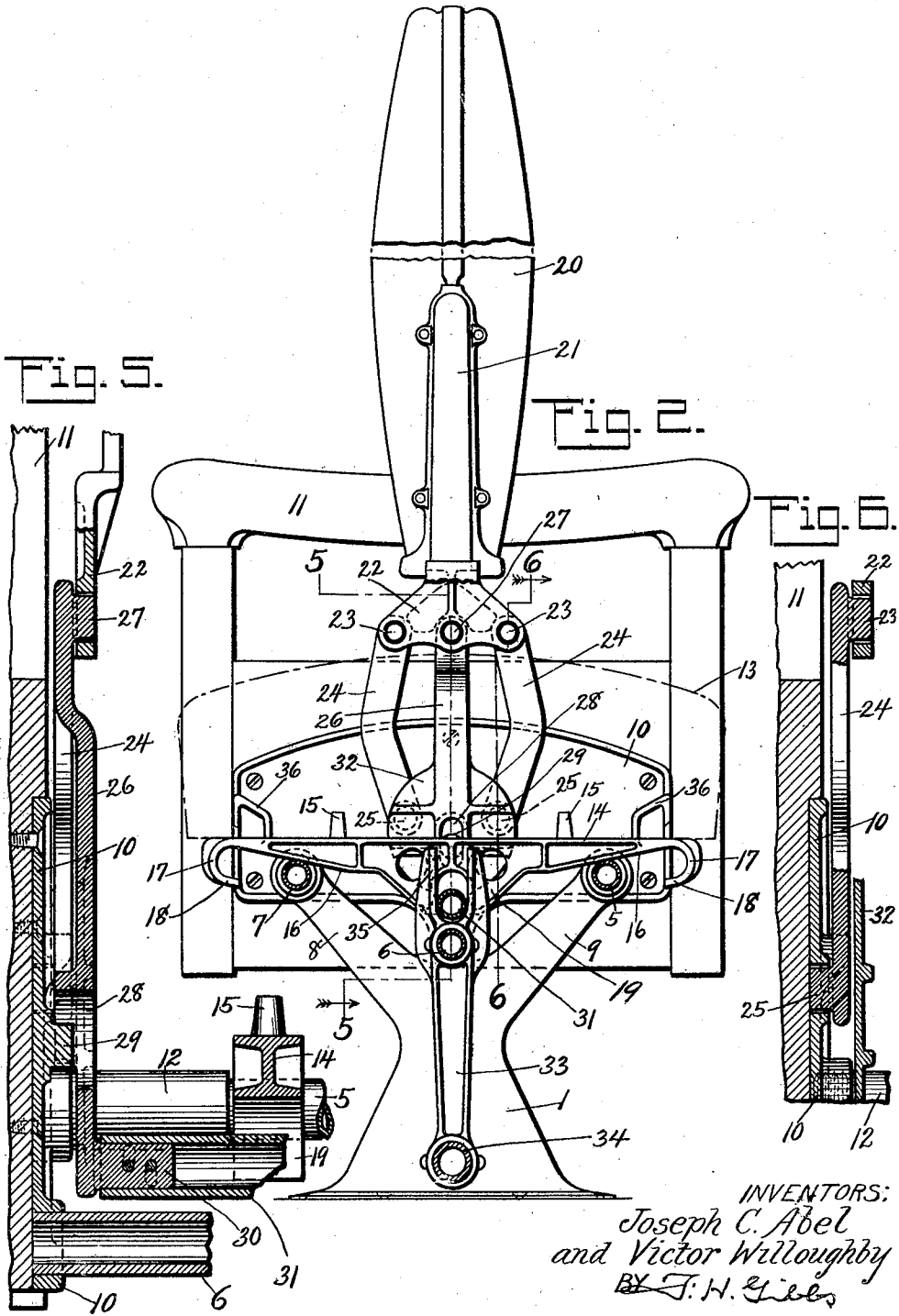

INVENTORS:
Joseph C. Abel
and Victor Willoughby
BY J. H. Gibbs

ATTORNEY.

April 1, 1924:

J. C. ABEL ET AL

1,488,659

WALK OVER SEAT

Filed Feb. 5, 1921

3 Sheets-Sheet 3

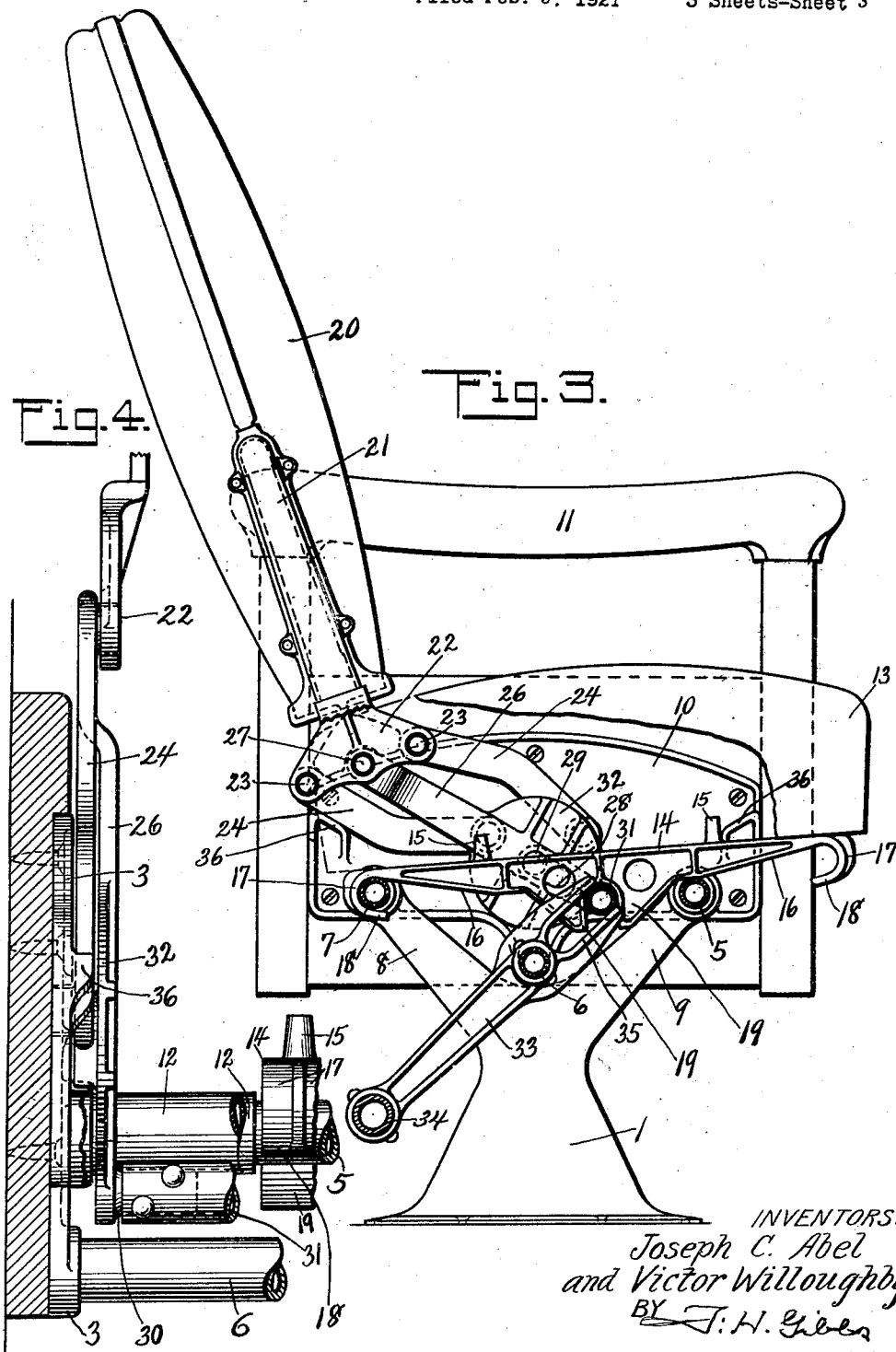

INVENTORS:
Joseph C. Abel
and Victor Willoughby
BY *J. H. Gibbs*
ATTORNEY.

UNITED STATES PATENT OFFICE.

JOSEPH C. ABEL, OF BROOKLYN, NEW YORK, AND VICTOR WILLOUGHBY, OF RIDGEWOOD, NEW JERSEY, ASSIGNORS TO AMERICAN CAR AND FOUNDRY COMPANY, OF ST. LOUIS, MISSOURI, A CORPORATION OF NEW JERSEY.

WALK-OVER SEAT.

Application filed February 5, 1921. Serial No. 442,793.

To all whom it may concern:

Be it known that JOSEPH C. ABEL and VICTOR WILLOUGHBY, residing at Brooklyn, Kings County, New York, and Ridgewood, Bergen County, New Jersey, respectively, and being citizens of the United States, have invented certain new and useful Improvements in Walk-Over Seats, of which the following is a full, clear, and exact description, such as will enable others skilled in the art to which it appertains to make and to use the same, reference being had to the accompanying drawings, which illustrate the preferred form of the invention, though it is to be understood that the invention is not limited to the exact details of construction shown and described, as it is obvious that various modifications thereof within the scope of the claims will occur to persons skilled in the art.

In said drawings:

Figure 1 is an elevation, partly in section, of our improved seat, the back being midway between its extreme positions;

Figure 2 is a section taken on the line 2-2 of Fig. 1, the seat cushion being shown in dotted outline;

Figure 3 is a view similar to Fig. 2 with the back shown in an extreme position and the seat cushion shown partly broken way;

Figure 4 is a view in elevation of the links and levers connecting the seat back to the supporting means at the wall end of the seat;

Figure 5 is a section taken on the line 5-5 of Fig. 2; and

Figure 6 is a section taken on the line 6-6 of Fig. 2.

It is an object of our invention to provide an improved seat of the walk-over type wherein means are provided for holding in place the links that secure the back to the aisle and wall plates, for operating the foot rail simultaneously with the back and for securing the seat cushion to the side rails so as to prevent tipping of the cushion.

In the drawings, 1 designates a pedestal adapted to be secured to the floor 2 of the car and 3 designates a wall plate secured to the side wall 4 of the car. Carried in pockets formed in the plate 3 are the tubular members 5, 6 and 7, the members 5 and 7 being the side rails of the seat and extending through openings in the ends of the arms 8

and 9 of the pedestal 1. The members 5, 6 and 7 all project beyond the pedestal 1 and have their ends mounted in pockets in the aisle plate 10 which carries the seat end and arm 11. The foot rest shaft 6 is mounted so as to pass between the arms 8 and 9 of the pedestal 1 and to rotate in the pockets in the plates 3 and 10. The members 5 and 7 are provided with reinforcing sleeves 12 at their ends, screw threaded into the pockets in the aisle and wall plates 3 and 10 and carry the reinforcing sleeves on the members 5 and 7 are provided with right and left hand threads at their opposite ends and the aisle and wall plates are threaded accordingly so that the arms 11 may be brought into line when the seats are placed in a car by rotating the members 5 and 7 and shifting the aisle plates 10.

The seat cushion 13 is mounted on cushion carriers 14 having projections 15 engaging with the cushion and inclined surfaces 16 adapted to engage with and travel on the side rails 5 and 7, the sleeves 12 and 12' serving as guides for the carriers 14. The inclined surfaces end in hooks 17 having inwardly extending portions 18 adapted to engage beneath the side rails 5 and 7 to prevent tipping of the cushion when the cushion is in a position at the limit of its movement. At their centers the carriers 14 are provided with spaced downwardly projecting portions 19 which form U-shaped slots open at the bottom.

The seat back 20 has scabbards 21 mounted at each end in which are inserted seat back swords having triangular ends 22 provided with openings at the lower corners in which are inserted the lugs 23 on the bent links 24. The other ends of the links 24 are provided with lugs 25 which are inserted in openings in the plates 3 and 10, the lugs 25 projecting from the links 24 in a direction opposite to that of the lugs 23.

Lever 26 has lugs 27 engaging openings in the seat back sword ends 22 midway between the openings engaged by the lugs 23. The levers 26 also have slots 28 engaging on lugs 29 on the wall and aisle plates 3 and 10 and lugs 30 which are joined by the cross bar 31, the cross bar 31 being a tubular member fitted on the lugs 30 and engaging in the slots formed by the projecting portions 19 on the carriers 14. Intermedi-

ate of its ends the lever 26 is enlarged to provide a disk-shaped portion 32 of sufficient size to overlap the ends of the links 24 and hold the lugs 25 in their respective openings when the seat is assembled.

Mounted on the foot rest shaft 6 are the foot rest arms 33, pinned to the shaft 6, and having the foot rest rail 34 mounted in openings in the lower ends of the arms 33. The upper ends of the arms 33 are slotted, as at 35, to receive the cross bar 31.

In use, when the seat back 20 is moved from one extreme position, in which one set of levers 24 engage the adjacent stops 36 on the plates 3 and 10, to the other extreme position, in which the other set of levers 24 engage adjacent stops 36 on the plates 3 and 10, the links 24 hold it in position relatively to the wall and aisle plates 3 and 10. Movement of the back 20 also operates the levers 26 which carry with them the cross bar 31. The cross bar 31, through its engagement in the slots between the projecting portions 19 on the carriers 14, operates the carriers 14 and the seat cushion 13 so that as the back 20 is moved in one direction the cushion 13 is moved in the opposite direction from a position in which one set of hook portions 17 engage with a side rail member 5 or 7 to a position in which the other set of hook portions 17 engage with the other side rail member. The cross bar 31 also engages in the slots 35 in the foot rest arms 33 so that the arms 33 and foot rest rail 34 are operated simultaneously with the movement of the back 20 and cushion 13 thus positioning the foot rest rail 34 properly for each change in the seat.

What we claim is:

1. In a car seat, wall and aisle plates, side rails connecting said plates, a cushion, carriers for said cushion carried by said side rails, a shaft journaled in said plates, arms forked at one end carried by said shaft, a foot rest rail connecting the opposite ends of said arms, a back, links connecting said back and said plates, levers slidably fulcrumed

on said plates and pivotally connected to said back to be operated by said back and a cross bar connecting said levers and adapted to engage the forked ends of said arms and said cushion carriers to shift said foot rest rail and said cushion carriers from one operative position to another.

2. In a car seat, wall and aisle plates, adjustable means connecting said plates, a back, links connecting said back and plates, levers adapted to hold said links in position and having fulcrums on said plates and connections to said back, a cross bar carried by said levers, a shaft journaled in said plates, forked arms carried by said shaft and adapted to receive said cross bar and a foot rest rail carried by said arms.

3. In a car seat, wall and aisle plates, side rails connecting said plates, a back, links connecting said back and plates, a shaft rotatably mounted in said plates, slotted arms carried by said shaft, a foot rest rail carried by said arms, levers operated by said back and adapted to hold said links in place and a cross bar connecting said levers and engaging in the slots in said arms.

4. In a car seat, wall and aisle plates, side rails connecting said plates, a cushion, carriers for said cushion carried by said side rails, a shaft journaled in said plates, arms carried by said shaft, a foot rest rail connecting said arms, a back, levers slidably fulcrumed on said plates and pivotally connected to said back to be operated by said back, links connecting said back and plates and held in engagement with said plates by said levers and a cross bar carried by said levers and engaging said arms and cushion carriers.

In witness whereof we have hereunto set our hands in the presence of two witnesses.

JOSEPH C. ABEL.
VICTOR WILLOUGHBY.

Witnesses:

JOSEPHINE MITCHELL,
R. W. SMITH.