

FLUID PRESSURE BRAKE  
 & ANALOGOUS SYSTEMS.

DRAFTSMAN

No. 839,893.

PATENTED JAN. 1, 1907.

W. H. SAUVAGE.  
 FLUID PRESSURE BRAKE.  
 APPLICATION FILED DEC. 1, 1905.

FIG. 1.

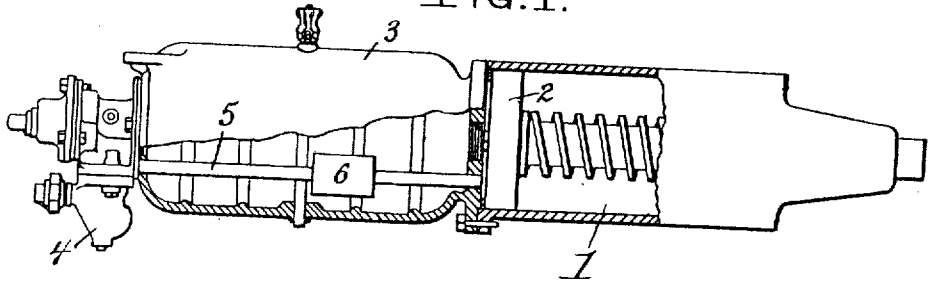

FIG. 2.

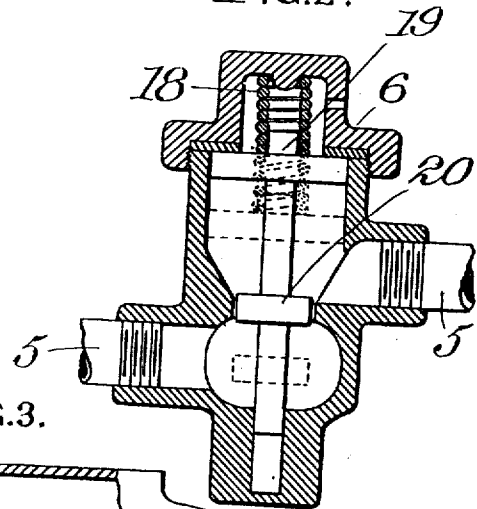

FIG. 3.

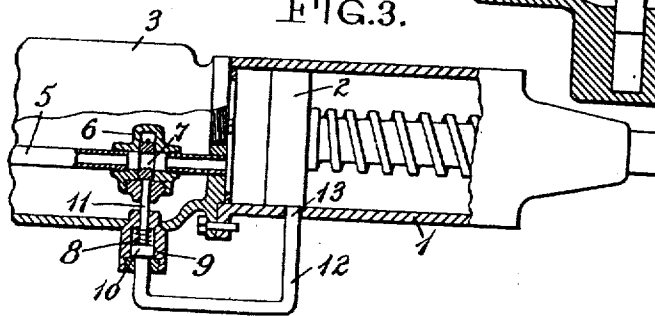
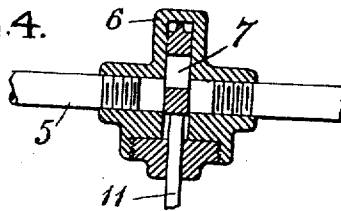

FIG. 4.



Witnesses  
*W. H. Humphrey*  
*M. S. Crawford*

Inventor  
*William H. Sauvage*  
 By *Attorney* *A. V. Perkins*

# UNITED STATES PATENT OFFICE.

WILLIAM HENRY SAUVAGE, OF NEW YORK, N. Y.

## FLUID-PRESSURE BRAKE.

No. 839,893.

Specification of Letters Patent.

Patented Jan. 1, 1907.

Application filed December 1, 1905. Serial No. 289,908.

To all whom it may concern:

Be it known that I, WILLIAM HENRY SAUVAGE, a citizen of the United States of America, and a resident of the borough of Manhattan, city, county, and State of New York, have invented certain new and useful Improvements in Fluid-Pressure Brakes, of which the following is a specification.

My invention relates to fluid-pressure brakes, and is designed to remedy certain defects and difficulties encountered in the use of what is commonly known as the "air-brake" system on railroad and electric cars.

With the present air-brake apparatus it is impossible to apply in brake-shoe pressure more than about ninety per cent. of the pressure of the wheel upon the rail without locking the wheel and causing it to slide upon the rail. Such sliding upon the rail not only reduces the effective drag of the brakes and lengthens the distance run before the train comes to a standstill, but it also ruins the wheels by flattening them. This limits the maximum brake-pressure usable with the present system. Moreover, even with the present quick-action triple valves there is always more or less jolting between the cars of a long train when a heavy application of brakes is made. This is due in part to unequal wear of brake-shoes in different cars or unequal adjustment of the brake-rigging, both of which result in unequal piston travel in the brake-cylinders and cause the brakes on one car to act more powerfully and quickly than those on its neighbor, and so allow the slowly-braked car to surge ahead, while the quickly-braked car holds back, and due in part to the fact that the brakes are applied in the cars nearest the engine before they are applied on the rear cars. A similar unequal action in the release causes the couplings between cars to sometimes break and draw-heads to pull out when the train is moving slowly and brakes are released, so that the standard freight-train practice is never to release the brakes when the train is moving slowly, but to bring the train to a full stop before releasing the brakes in order to avoid breaking the train in two.

My invention avoids these difficulties by slightly delaying the application of the full braking power after the triple valve has acted and also in delaying the full release of the brakes after the triple exhaust is open. Thus the brake-shoe is allowed to adjust itself to the wheel-face before the full pres-

sure comes on it, and the several cars of a long train adjust themselves in their proper position quietly upon the gradual application of the brakes before the full power is applied, so that all jerking and bumping is avoided. In the same way a gradual release tends to diminish the inequalities existing at the moment of complete release.

The preferred form of apparatus embodying my invention with some modifications thereof are shown in the accompanying sheet of drawings, in which—

Figure 1 is a side elevation and partial section of the standard freight brake-cylinder, auxiliary-reservoir, and triple valve with my invention applied. Fig. 2 is a sectional enlarged detail view of one form of choking-valve. Fig. 3 is a sectional view of another form open. Fig. 4 shows the same form in operative position.

Throughout the drawings like reference-figures indicate like parts.

1 is the brake-cylinder; 2, the piston; 3, the auxiliary reservoir, and 4 the usual form of triple valve in the well-known standard air-brake apparatus.

5 is the pipe extending from the triple valve to the brake-cylinder. In this pipe 5 I provide means for choking down the too rapid flow of air to the brake-cylinder during the whole or a part of the stroke of the piston 2. This consists, preferably, of a throttling or choking valve 6 of suitable construction—such, for instance, as shown in Fig. 3—which when closed compels the air to pass through the opening 7 of restricted cross-section. Normally this valve is held open by the spring 8 or other means. It is closed by air-pressure in cylinder 9 operating on piston 10, connected to valve-stem 11. Cylinder 9 is connected by pipe 12 with brake-cylinder 1 through a port 13 in the side of said cylinder 1. This port 13 is so located that it will be opened by the piston 2 when the same has traveled a sufficient distance—say five and one-half inches—to take up the brake-shoe clearance and the lost motion in the brake-rigging.

The operation of this form of device is as follows: When an application of the brakes is made, air freely enters the brake-cylinder and piston 2 quickly moves out to set the brakes. When the brakes are set, however, air passes back through pipe 12 and nearly closes choking-valve 6, as shown in Fig. 4. The flow of air is then restricted and the full

application of brake-pressure is delayed for a second of time or, perhaps, more or less. On releasing the brakes the pressure comes off slowly until the piston 2 has passed port 13, when valve 6 opens wide and the remaining air is promptly discharged.

The advantages of this invention comprise the avoidance of the severe blow with which the brake-shoes otherwise strike the wheels in emergency applications of the brake and the equalizing effect as to time of complete application and release on cars differently located in the train and differently adjusted as to piston travel. In the arrangement heretofore used when an emergency application is made piston 2 jumps out like a shot fired from a gun with a force of about ten thousand pounds or more. This slams the brake-shoes up against the wheels like so many hammers. The brake-shoe hits the wheel so sharply that the little projections which form its surface embed themselves in the surface of the wheel and lock it against movement, producing a skidding of the wheel on the rail. With my invention this action is avoided, and a much greater final brake-pressure can be employed without sliding the wheels. In the arrangement heretofore used also the brakes go on instantly with full power in the first car, while in a fraction of a second later they go on the second car, and so on down the train. As a car going a mile a minute travels eighty-eight feet in a second, there may be ample time for the second car to run up on the first one with a sharp bump before the brake goes on in the second car, especially if the second car has three or four more inches of piston travel than the first car, and accordingly gets about twenty per cent. less braking power. With my invention the full braking power will not be attained on car No. 1 until the initial braking action has begun down at car No. 20 or farther, and so during the interval all the cars have had time to adjust themselves as to their relative positions before the full effect of the brakes is felt, and there is no pulling and bumping. In releasing the brakes while the train is moving slowly the reverse action takes place, and the tendency of the first cars to surge ahead away from the rear cars is so far reduced that the train will not pull in two.

In the form of valve shown in Fig. 2 the choking action is a function of the pressure. The spring 18 is graduated, so as to permit the plunger 19 to lift at a given air-pressure, which might be fifty pounds to the square inch, if the purpose was simply to prevent sliding of the wheels, and experiments proved that fifty pounds could safely be applied to a given size cylinder without locking the wheels. The whole system would then be adjusted to apply a maximum brake-cylinder pressure of seventy-five or one hundred

pounds. Upon making an emergency application then the fifty-pounds pressure would freely flow into the cylinder; but when that was exceeded the plunger 19 would rise and the choking-valve 20 nearly close, so wire-drawing the air that the maximum brake-cylinder pressure could only be more slowly reached. If the purpose was to so delay ordinary heavy applications as to prevent surging of the cars, as above explained, the spring 18 would be graduated to a pressure of twenty pounds or less. In Fig. 2 the valve is shown in full lines in choking position and in open position in dotted lines.

It should be understood that the purpose of my invention is not to delay the initial action of the brakes or triple valves nor to impair the simultaneousness of the application on a series of cars. The quickest-acting triple valve possible should be used. The purpose of my invention is to slightly extend the period of time between the initial brake application and the attainment of the maximum brake-power for that application after the triple valve has acted, this resulting in the benefits above set out.

It is evident that various forms of choking-valves and other restricting means could be used to reduce the suddenness of the emergency application, and that other than pneumatic means might be employed for timing the action of such choking means.

Having therefore described my invention, I claim—

1. In a fluid-pressure brake system, the combination with the brake-cylinder, auxiliary reservoir and triple valve, of a connection between the triple valve and brake-cylinder provided with a passage-way of more restricted cross-section than the supply-passages through the triple valve, during a portion of the period of brake application and release.

2. In a fluid-pressure brake system, the combination with the brake-cylinder, auxiliary reservoir and triple valve, of a connection between the triple valve and brake-cylinder provided with apparatus arranged to produce a passage-way of more restricted cross-section than the supply-passages through the triple valve, together with means for so reducing the effective cross-section of said passage-way when the piston of the brake-cylinder is near the end of its outstroke and maintaining such reduction during the initial portion of the return stroke.

3. In a fluid-pressure brake system, the combination with the brake-cylinder, auxiliary reservoir and triple valve, of a connection between the triple valve and brake-cylinder provided with a passage-way of more restricted cross-section than the supply-passages through the triple valve, together with means for reducing the effective cross-section of said passage-way when the piston of the

brake-cylinder is near the end of its out-  
stroke, said means comprising a pressure-  
operated valve and means for transmitting  
to it the pressure within the brake-cylinder.

5 4. In a fluid-pressure brake system, the  
combination with the brake-cylinder, auxil-  
iary reservoir and triple valve, of a connec-  
tion between the triple valve and brake-cylinder  
provided with a passage-way of more re-  
10 stricted cross-section than the supply-pas-  
sages through the triple valve, together with  
means for reducing the effective cross-section  
of said passage-way when a pressure of prede-  
termined amount has been attained in the  
15 brake-cylinder.

5. In a fluid-pressure brake system, the  
combination with the brake-cylinder, auxil-  
iary reservoir and triple valve, of a connec-  
20 tion between the triple valve and brake-cyl-  
inder provided with a passage-way of more  
restricted cross-section than the supply-pas-  
sages through the triple valve, together with  
means for reducing the effective cross-section  
of said passage-way when a pressure of prede-  
25 termined amount has been attained in the  
brake-cylinder, said means comprising a  
pneumatically-operated valve.

6. In a fluid-pressure brake system, the  
combination with the brake-cylinder, auxil-  
iary reservoir and triple valve, of a connec-  
30 tion between the triple valve and brake-cylinder  
provided with a passage-way of more re-  
stricted cross-section than the supply-pas-  
sages through the triple valve, together with

means for reducing the effective cross-section 35  
of said passage-way when a pressure of prede-  
termined amount has been attained in the  
brake-cylinder, said means comprising a  
pneumatically-operated valve located in the  
40 connection from triple valve to brake-cylin-  
der, and adapted to partially close itself au-  
tomatically when such predetermined pres-  
sure of the air passing through the valve is at-  
tained.

7. The combination with the brake-cylind- 45  
er, auxiliary reservoir and triple valve of  
means for choking down the flow of air to  
and from the brake-cylinder in an emergency  
application of the brake and release thereof.

8. The combination with the brake-cylind- 50  
er, auxiliary reservoir and triple valve, of  
means for choking down the flow of air to the  
brake-cylinder before the maximum pressure  
is attained therein.

9. The combination with the brake-cylind- 55  
er, auxiliary reservoir and triple valve, of  
means for choking down the flow of air to the  
brake-cylinder before the maximum pres-  
sure is attained therein, and choking down  
60 the flow of air from the brake-cylinder until  
a predetermined reduction of brake-cylinder  
pressure is attained.

Signed at New York, N. Y., this 28th day  
of November, 1905.

WILLIAM HENRY SAUVAGE.

Witnesses:

N. G. CRAWFORD,  
W. H. PUMPHREY.