

April 7, 1936.

J. B. D. THOMPSON ET AL

2,036,555

CAR CONSTRUCTION

Filed April 23, 1934

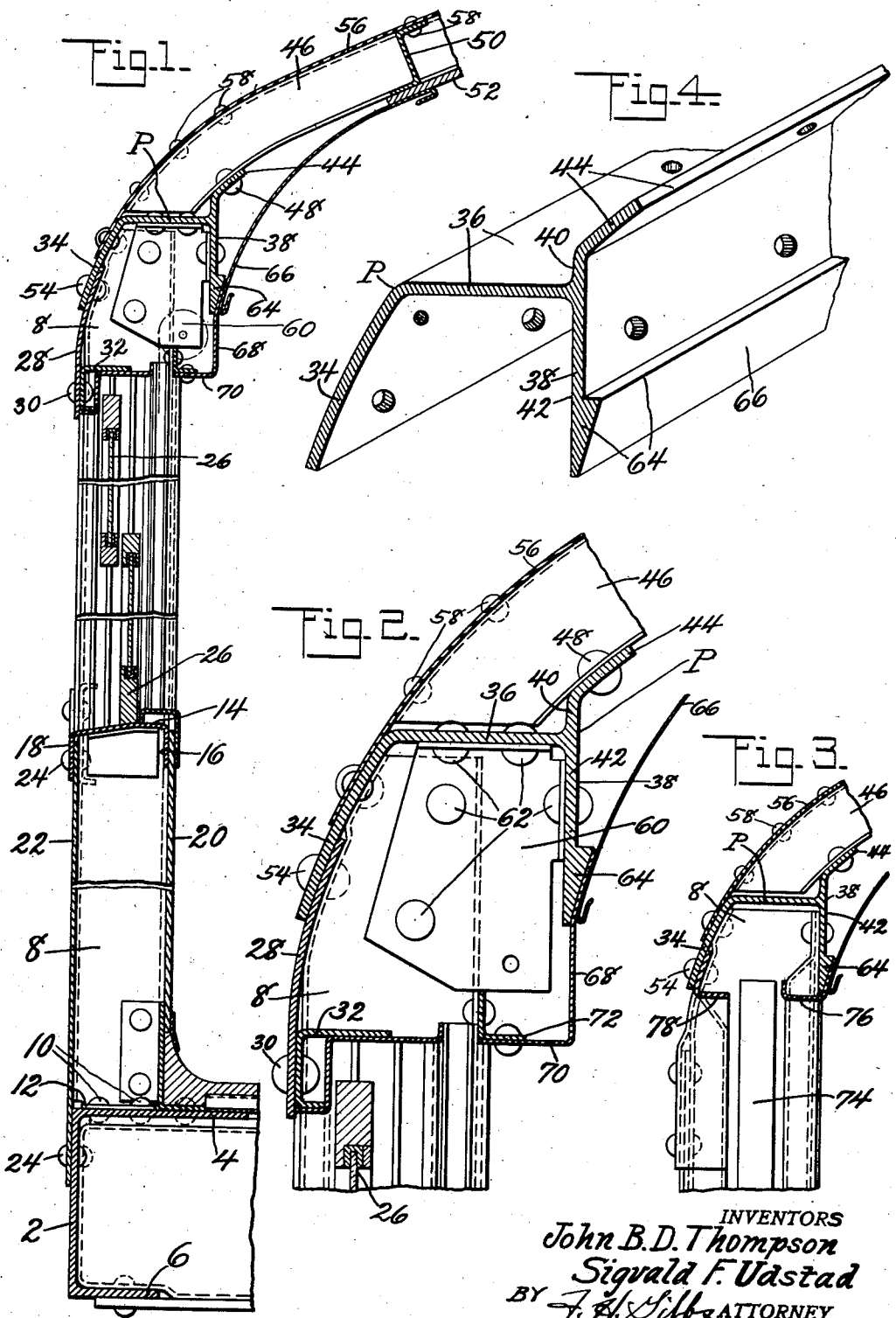

INVENTORS  
John B. D. Thompson  
Sigvald F. Ustvad  
BY *J. H. Hill* ATTORNEY

# UNITED STATES PATENT OFFICE

2,036,555

## CAR CONSTRUCTION

John B. D. Thompson and Sigvald F. Udstad,  
Berwick, Pa., assignors to American Car and  
Foundry Company, New York, N. Y., a corpo-  
ration of New Jersey

Application April 23, 1934, Serial No. 721,870

3 Claims. (Cl. 105—401)

This invention relates generally to improve-  
ments in railway car construction and has par-  
ticular reference to a new and improved side  
plate.

At the present time the general trend in rail-  
way car construction is toward railway cars of  
lighter construction than those heretofore man-  
ufactured and use has been made of aluminum  
alloys for various parts of a railway car. In line  
with this general trend the present invention  
comprises the provision of a railway car formed  
of material of relatively light weight but of such  
a nature as to possess the necessary strength for  
resisting strains and stresses imposed thereupon  
in service and one object of the present invention  
is the provision of a new and improved railway  
car construction embodying the use of relatively  
light but durable metal elements.

A further object of this invention is the pro-  
vision of a side plate formed of extruded alumi-  
num or aluminum alloys.

Another object of this invention is the provi-  
sion of a new and improved construction at the  
junction of the roof and upper portion of the  
side wall of a railway car.

Other objects and advantages of this inven-  
tion will be apparent from the following descrip-  
tion taken in conjunction with the accompanying  
drawing, in which

Figure 1 is a vertical sectional view through  
the side of a car body including a portion of the  
roof structure;

Fig. 2 is an enlarged detail view of a part of  
the car construction shown in Fig. 1 at the junc-  
ture of the roof and upper portion of the side  
wall;

Fig. 3 is a fragmentary sectional view of the  
car construction at the door opening; and

Fig. 4 is a perspective view of the side plate.

Referring now more particularly to the draw-  
ing in which similar characters of reference  
designate similar parts in the several views, the  
car construction shown in the drawing, particu-  
larly Fig. 1, comprises a side sill 2 formed of  
relatively light material though obviously it may  
be formed of a commercially rolled section, said  
sill being generally channel shaped in form and  
comprising a top chord 4 and a bottom chord 6,  
the latter being, in the instance shown, of less  
width than the top chord 4. To the side sill 2  
are secured a plurality of body posts 8 in any  
suitable manner as by rivets 10 extending through  
flanges 12 formed at the lower end portions of  
said posts. Between adjacent posts are belt rail  
sections, one thereof being shown in section in

Fig. 1 and comprising a channel shaped press-  
ing 14 the edge portions of which are downwardly  
flanged as at 16 and 18, respectively, flange 16  
lapping the upper edge portion of an interior  
finish member 20 while the external flange 18  
overlaps the upper edge portion of the external  
side wall sheathing member 22; members 20  
and 22 being secured to the body posts 8 and  
member 22 being secured to the side sill 2 by  
suitable fasteners 24. The side wall of the car  
body is provided with window openings having  
windows 26 therein and, as can be seen in Fig. 1,  
the belt rail 14 constitutes the lower rail of the  
window frame.

The side wall of the car also includes external  
sheathing members 28 the lower edge portions of  
which at the window openings are secured as by  
rivets 30 to the upper window frame members 32.  
The upper external sheathing members 28 have  
their upper portions inwardly bent to underlie  
the inner surface of the correspondingly curved  
depending flange 34 of a side plate indicated  
generally at P and comprising a unitary con-  
struction formed of extruded aluminum or alu-  
minum alloy and including a horizontally ar-  
ranged web 36 from which the before mentioned  
flange 34 depends and a vertically arranged at-  
taching flange 38 arranged opposite flange 34 and  
formed at substantially right angles with web 36  
with portions extending both above and below  
the web 36 as shown at 40 and 42, respectively.  
As clearly shown in the drawing, the portion 40  
above web 36 has its upper edge portion bent  
inwardly to define an attaching flange 44 which  
underlies and supports the roof carlins 46 and  
said carlins are secured to the attaching flange 44  
by suitable fasteners such as the rivets 48.

The carlins 46 may be and preferably are ex-  
truded aluminum sections and extending be-  
tween adjacent carlins are purlins 50, substan-  
tially Z-shaped in cross section, and of a size  
sufficient to support the head lining 52 of the  
car body as shown in Fig. 1.

The attaching flange 34 is connected to the  
external sheathing member 28 which may, if de-  
sired, be a letter board, by suitable fasteners such  
as the rivets 54. The carlins 46 and purlins  
50 support or form a part of the roof indicated,  
in the instance shown, as of thin gauge 56 riveted  
as at 58 or otherwise secured to the carlins and  
purlins and having its side edge portions over-  
lapping the attaching flange 34 and secured to  
said flange by any suitable or desired fastening  
means.

As more clearly shown in Fig. 2, the side plate

P is connected to the upper end portions of the body posts 8 through the medium of gussets 60 riveted to the web 36 and flange 42 of said side plate and to the posts 8 as shown at 62. The outer portions of the upper end portions of the posts 8 are shaped to conform to the general curvature of the letter board 28 and the curvature of the flange 34 of the side plate P.

The lower end portion of the depending flange 42 of side plate P is of increased thickness as shown clearly in the drawing at 64 and its outer surface is beveled as at 66 to form an attaching surface for interior head finish member 66 which is connected in any suitable manner with the head lining 52 and, between the window openings, overlaps an upper window frame member 68 secured to the attaching portion 64 and depending therefrom with its lower end portion inwardly flanged as shown at 70 to underlie angle 72 extending between and riveted to adjacent body posts 8.

Fig. 3 discloses a detail sectional view taken at the door opening of the car and, in the instance shown, the door which is indicated at 74 is of the sliding type and slides between rail members 76 and 78, respectively; member 76 being secured to the attaching portion 64 of flange 42 of side plate P while member 78 extends across the door opening parallel to member 76 and is secured by rivets to the attaching flange 34 of the side plate.

From the above description it is believed that those skilled in the art will recognize that the construction shown and described herein constitutes a strong and durable yet simple and easily manufactured car construction, which comprises a side plate as an extruded aluminum section which supports the roof and is so formed as to provide attaching means for interior car finish members.

The drawing herein illustrates one embodiment of the invention but it is to be understood that it is for illustrative purposes only and various changes in the form and proportions of the construction may be made within the scope of the appended claims without departing from the spirit of the invention.

What is claimed is:

1. In a car structure, a side plate comprising a unitary extruded metal section formed to provide, a substantially horizontal web, an outer flange depending from the web and constituting an attaching element to which the car roof sheet

is secured, and an inner flange arranged in a plane substantially normal to said web and extending above and below the latter, the portion above the web having its upper part inwardly deflected to provide a supporting element for roof carlins and upon which said carlins directly bear, the lower portion of the inner flange being of increased thickness and formed with a beveled inner surface constituting an attaching portion for interior car finish members.

2. In a car structure, a side plate comprising a unitary extruded metal section formed of an alloy possessing substantially the characteristics of aluminum and comprising a substantially horizontal web, an outer flange depending in a curve from said web to provide an attaching element to which the car roof sheet is secured and an inner flange arranged in a plane substantially normal to said web and extending above and below the latter, the portion above the web having the upper part thereof deflected inwardly to provide a supporting element for roof carlins and upon which said carlins directly bear, the lower portion of said inner flange being of increased thickness and formed with a downwardly and outwardly inclined inner surface constituting an attaching portion for car interior finish members.

3. In a car structure, a side plate comprising a unitary extruded metal section formed to provide a substantially horizontal web, an outer flange depending in a curve from the web and constituting an attaching element to which the car roof sheet is secured, an inner flange arranged in a plane substantially normal to said web and extending above and below the latter, the portion above the web having a part thereof inwardly deflected to provide a supporting element for roof carlins and upon which said carlins directly bear, the lower portion of the inner flange being formed of increased thickness and provided with a beveled inner surface constituting an attaching portion for interior car finish members, body posts extending into the space between the inner and outer flanges of the side plate and having the upper end portions thereof shaped to conform to the curvature of the outer flange of the side plate, said body posts being spaced from the inner flange of the side plate, and gussets connecting the inner flange and the horizontal web of said side plate with the body posts.

JOHN B. D. THOMPSON.  
SIGVALD F. UDSTAD.