

SPACKE

MOTOR CARS

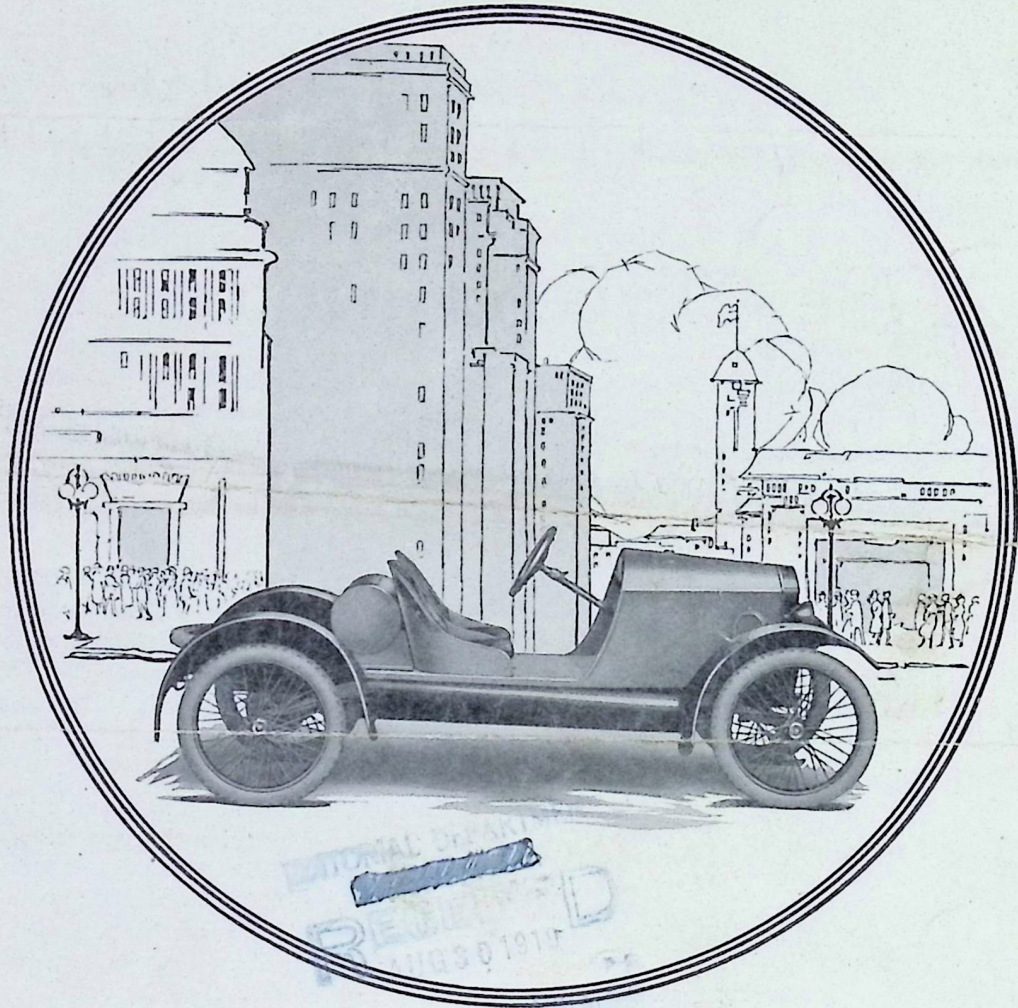

A New Type of Motor Car
Combining Ease of Operation, Light
Weight and Economy of Upkeep

Manufactured by
The Spacke Machine & Tool Co.
Indianapolis, Ind., U. S. A.

Distributed by
A. B. Norwalk & Company, Inc.
Times Bldg., New York City

SPACKE MOTOR
CARS

Price \$295.00
Delivery Case \$20 Extra
F. O. B. Factory

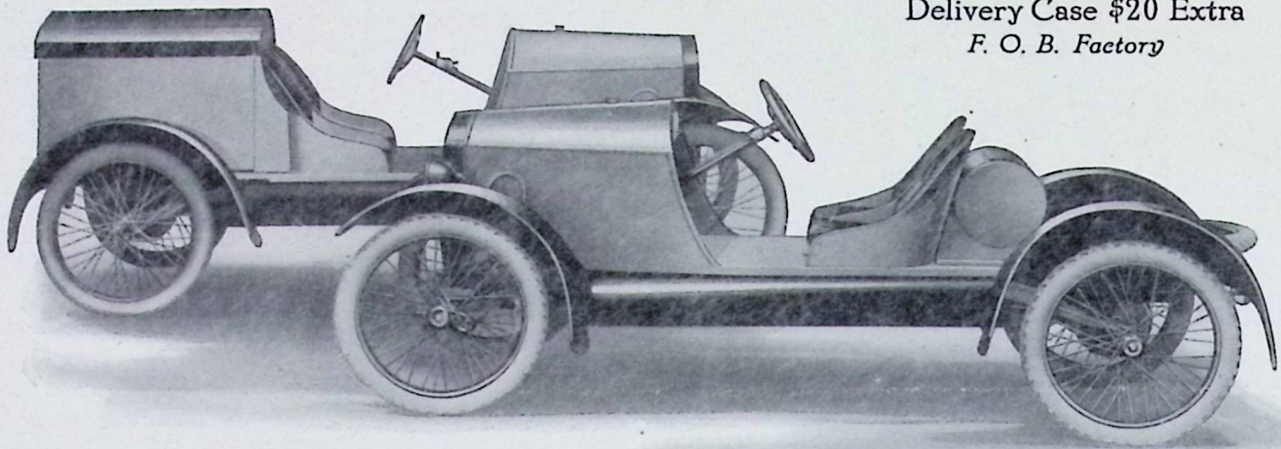

A New Type of Motor Car

The Spacke Motor Car cuts the cost of transportation in half.

Its first cost is far less than any other car—and the cost of operation and upkeep actually saves half the ordinary cost of even a small car.

This saving is remarkable when you consider that it has attractive appearance and is modeled on the lines of speedsters costing over ten times the Spacke price.

In the great saving this new type of car brings—you do not sacrifice speed or ease of handling. It will give you all the speed the law allows and throttle down to slowest traffic with a quick pickup to high speed.

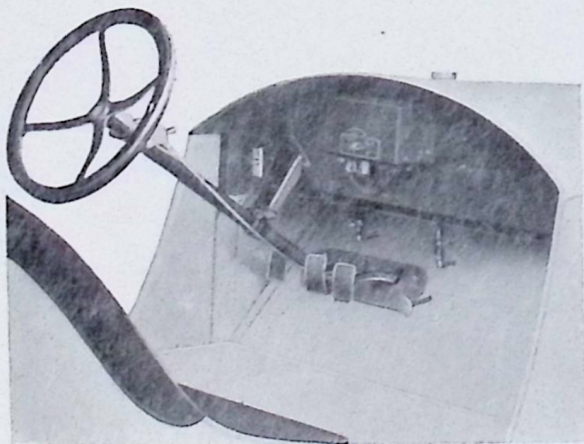

Showing foot controls for two speeds forward and reverse and foot accelerator; hand controls for spark and throttle on steering column and light switch on dash.

The secret of the Spacke Car is light weight and simplicity. Its design eliminates half the weight of the usual small car and saves fuel, tires and upkeep in proportion. Its simple, sturdy power plant and working parts make it easy to operate and care for—also add thousands of miles of service.

The fact that THE SPACKE MACHINE & TOOL CO., who for the past twenty years have been recognized as one of the leading manufacturers of high-grade motors, transmissions, axles and automotive parts, are putting their name and reputation back of this car, is the best guarantee of its durability.

The SPACKE is not only the lowest-priced automobile on the market, but the most economical to operate. A SPACKE can be operated for a whole year and cover 10,000 miles, at a cost not to exceed \$4.00 per week. This allows 30c per gallon for the maximum of 250 gallons of gasoline required (total \$75.00), and leaves \$125.00 for tires, oil and repairs.

FOR QUICK COMMERCIAL DELIVERY, the SPACKE has no rival, as it will not only make deliveries quickly and cheaply, but after business hours the owner can, in a few minutes, detach the delivery case and use it as a pleasure car.

And the SPACKE not only appeals to the man who cannot afford a high-priced car, but also to the "moneyed" man who wants an auxiliary car to take him to and from the railroad station, the golf links or country club.

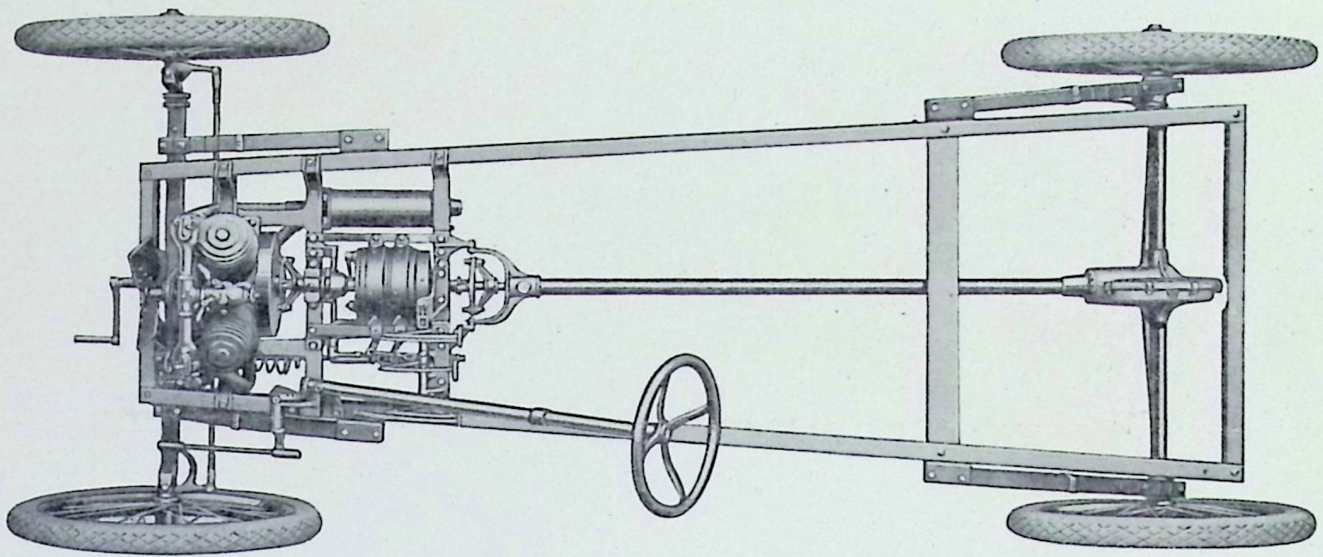

Proved Construction Features

The Spacke Chassis is the sturdiest, most capable and durable mechanism ever offered in a light car.

From the pressed steel channel frame through every part it insures the greatest value in design, material and construction.

The famous air-cooled Spacke 9-13 horsepower De Luxe Motor—proved by years of satisfactory service—saves you in weight, fuel, cost and upkeep and provides ample power for every requirement. Back of it is the efficient, Spacke Transmission, insuring a maximum delivery of power to the rear wheels.

Wire wheels, with 28 x 3 tires, add to the snappy appearance and save in tire cost.

The pressed-steel, racing type body is comfortable and has bucket seats. The wheel base is 90 inches—length over all 118 inches. The tread of the SPACKE is 46 inches. The 10 inch saving over the standard tread is a decided advantage on crowded city streets, as the small car can travel in and out through the traffic while the heavier car is left far behind. The SPACKE can also successfully negotiate the country roads, its ample road clearance (8-in.) and its light weight (800 lbs.) enabling it to avoid the bumps and straddle the ruts as readily as any car.

The SPACKE comes equipped with electric Head-lights, Tail Lamp, Storage Battery, Pump, Jack and Pliers. The extra wheel complete with tire, lists at \$25.00. Top and Wind Shield are \$15.00 extra for the two.

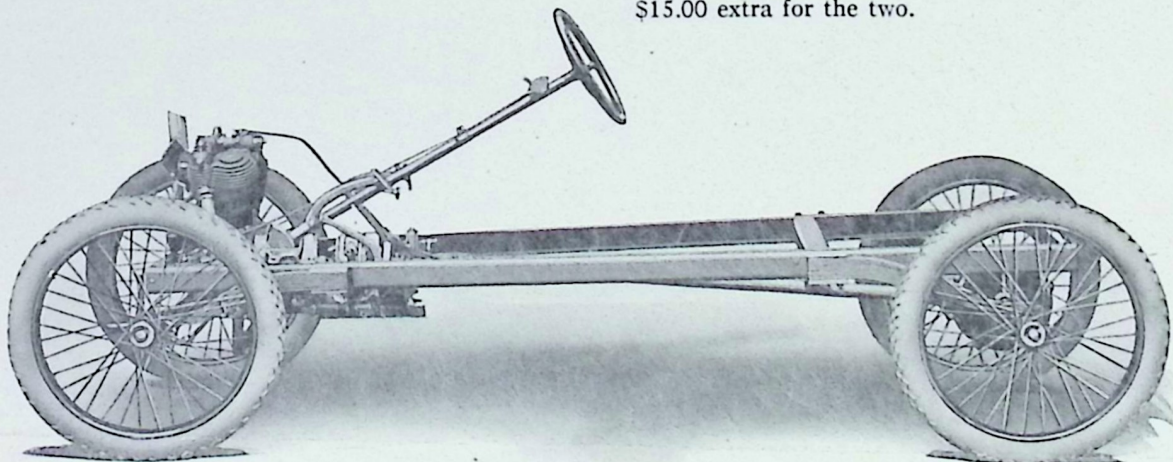

SPACKE MOTOR CARS

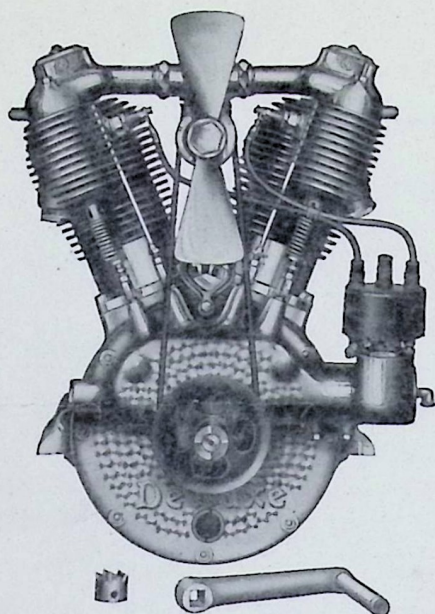

The Spacke 9-13 DeLuxe Motor

The Spacke Car is equipped with this efficient, air-cooled engine, delivering from 9 to 13 horsepower. Besides being proven in thousands of cases in actual service these engines have operated at high speed on test in a closed room for 52 hours without overheating.

The Spacke Transmission

The Spacke Transmission used on Spacke Cars is both simple and durable and has been designed especially for this type of car.

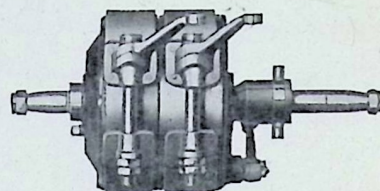

Every feature is light, strong and efficient. It delivers the greatest amount of power to the rear axle.

Outline Specifications

LENGTH OVER ALL—118 inches;	WHEEL BASE—90 inches;	TREAD—46 inches
ENGINE - - - - -	- - - - -	Spacke 9-13 DeLuxe
NUMBER OF CYLINDERS - - - - -	- - - - -	2
BORE AND STROKE - - - - -	- - - - -	3½" x 3⅝"
HORSE POWER - - - - -	- - - - -	9-13
PISTON DISPLACEMENT - - - - -	- - - - -	70.62 cubic inches
CAM SHAFT DRIVE - - - - -	- - - - -	Helical Gears
COOLING - - - - -	- - - - -	Air
LUBRICATION - - - - -	- - - - -	Eccentric Pump and Splash
CARBURETOR - - - - -	- - - - -	Wheeler & Shebler
GASOLINE FEED - - - - -	- - - - -	Gravity with Foot Accelerator and Hand Control on Steering Post
IGNITION - - - - -	- - - - -	Atwater Kent. Hand Control on Dash and Steering Post
GEAR-SET - - - - -	(Own Make) Planetary, 2 speeds forward, 1 reverse	
FINAL DRIVE - - - - -	- - - - -	Bevel Gear 6 to 1 ratio
REAR AXLE - - - - -	- - - - -	Bevel Drive, 1⅛" Shaft
FRAME - - - - -	- - - - -	Pressed Steel Channel
TIRES - - - - -	- - - - -	28" x 3"
WHEELS - - - - -	Wire—Demountable. Enameled Black	
MOTOR BEARINGS - - - - -	- - - - -	Annular Ball
REAR AXLE BEARING - - - - -	- - - - -	Annular Ball
FRONT AXLE BEARING - - - - -	- - - - -	Cup and Cone
BODIES - - - - -	Racing Type—steel body—bucket seats—steel carrier case	
WEIGHT COMPLETE - - - - -	- - - - -	800 lbs. Delivery case 55 lbs. extra
MILES PER GAL. GASOLINE - - - - -	- - - - -	40 to 50
LIGHTS - - - - -	- - - - -	Electric
COLOR - - - - -	- - - - -	Battleship Gray
SPEED - - - - -	- - - - -	From 3-35 miles

Price \$295.00, f. o. b. factory