

SAN DIEGO'S

north county living

MAY 1976 ONE DOLLAR

**BEVERLY SILLS:
OPERA'S
HIGH PRIESTESS**

**BEWARE THE
SUNSHINE
SALESMAN!**

**HORSE SHOW
DOLLARS & SENSE**

**LOCAL
GET-AWAY
GUIDE**





**You get
the best
of both
worlds
at
La Jolla
Federal**

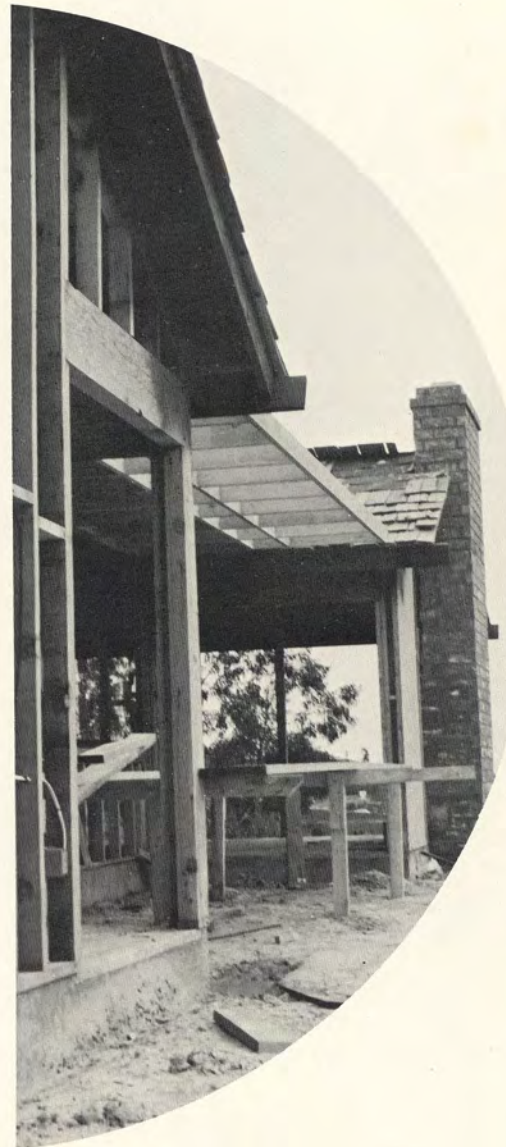

There's no better place to get help to finance your home. At La Jolla Federal, you can be sure of a sincere welcome and the same friendly, competent service we've offered ever since our founding in 1928.

And there's no better place for your savings than a high-earning savings program at \$105,000,000 La Jolla Federal. Where every dime of your money is invested right here in San Diego County.

Come to La Jolla Federal. You'll be better off.

la jolla federal
SAVINGS AND LOAN ASSOCIATION

"Helping people save for sunny days since 1928"

**PASEO DELICIAS, RANCHO SANTA FE
2187 NEWCASTLE AVE., CARDIFF-BY-THE-SEA
914 N. HIGHWAY 101, LEUCADIA**

Other offices in San Diego, Spring Valley, Fallbrook and Carlsbad.
Home office: 1100 Wall Street, La Jolla



**Once in a great while,
a truly extraordinary automobile arrives.**

**We have one now. The limited edition
Mercedes-Benz 450SLC.**

Very few Americans will be able to own a car like this in 1976. Only about 1600 of them. But for those fortunate few, the Mercedes-Benz 450SLC offers an extraordinary driving experience.

Don't let its sleek body design fool you. This is a 4-passenger automobile

with a full 10 cubic feet of luggage space. But the real story is beneath the hand-crafted exterior. The 450SLC is an automobile for drivers. Come in and arrange a thorough test drive. See what a true limited edition automobile is all about.



Hoehn Motors, Inc.
CARLSBAD

Interstate 5 at Palomar Airport Road, Carlsbad, CA 92008, (714) 729-0941; toll-free from San Diego, 453-5073; from Escondido, 744-3206.

RANCHO SANTA FE NURSERY'S

very, very special sale for the

MERRY, MERRY MONTH OF

MAY

ARA GRO
10-5-5

2 for 1 Sale!

Buy 1 gallon-

\$4.99
for both!

2nd one free!

General, all purpose fertilizer with
deodorized fish base-for flowers, fruits, vegetables and shrubs

We deliver

756-1455

Rancho Santa Fe Nursery

LETTERS

To the Editor:

Thanks for an interesting and informative inaugural restaurant column. I most certainly concur with Mr. Marston's assessment of Bucci's trout stuffed with crab — excellent.

I'll be interested in reading your review of Duke's, and plan to try it myself.

Sloane Haywood
San Diego

To the Editor:

Nothing happens in North County. Or almost nothing. For that reason I was delighted to discover a Calendar of Events in your April issue.

I was absolutely furious however when I got down to the Mandeville Auditorium to hear Cecil Lytle play to be informed that he was scheduled to play in MAY!

After driving back home, I rechecked your published information and discovered that your April issue carries a May Calendar. May I ask why! It is at the very least confusing, and at the very most misleading. Perhaps a letter of explanation from you might help.

J. Sprague
Encinitas

Editor's note: Because our publication date falls on the 10th of the month (and the speed of the post office is always in question) we feel a calendar of events for the following month will allow our readers to plan ahead. We apologize for any inconvenience we might have caused.

To the Editor:

Just a line to let you know how much I enjoyed reading Mark Mowrey's article, "Tennis Over 40" in the March issue of Living. Really found it a delightful and entertaining bit of reporting; also informative in a very humorous way. I think you would do well to search for and publish more of this type of feature writing on timely topics of general interest.

I might be a little prejudiced in my enthusiastic reaction to this particular article in that I have recently gone through the "agony and ecstasy" of re-learning tennis after a lapse of 25 years. Much of Mr. Mowrey's analysis applies all too painfully in my own case. His "stages of development" in relearning the game are perfect.

I am making some copies of his article which I will distribute to some of the "seniors" with whom I play. I am sure they will enjoy it as much as I did.

Ed Craig
La Jolla

LETTERS

To the Editor:

Thank you for your generous coverage of our home in Del Mar. The joy of living in it has been satisfaction enough for us, but it is always gratifying to be afforded the means of sharing our joy with others.

In particular we would like to compliment Wendy Herold. She has an individual writing style and commendable command of the language that makes her journalism an asset to your publication. We appreciate not only the attention and sense of awareness she brought to our home but we also appreciate her kind regard for our privacy.

We wish continued success to you and North County Living.

Donald Schoell, AIA
Del Mar

To the Editor:

Congratulations on your "new look." The overall effect is just beautiful. I especially like your new typefaces. I loved "Louella Liverwurst" and her new pink Gazette.

I must point out however, lest you think that you are perfect, that you spelled Buzzie incorrectly on the cover. It is Buzzie, not Buzzi. For shame!

Rudy Poehner
San Diego

To the Editor:

Thirty-eight years of marriage has surely done wonders for me! I'm indeed flattered by your photo of "Mr. & Mrs. Bob Crosby" on page 57 of the April 1976 issue. However I have no doubt that the new Mrs. Kim Fletcher was a bit shocked by seeing her picture with my name, while her husband still looks as though he's a bachelor in his photo solo.

Into each life a little rain must fall; so sorry if I misted up yours, but I couldn't resist the comment!

Jane Crosby
La Jolla

To the Editor:

Congratulations on your 12th Anniversary issue. The new type and table of contents page are beautiful. You are really living up to the prestige about which North County Living reports.

Raff Ahlgren
XETV/Channel 6

WORLD TEAM TENNIS!

See Evert, Nastase,
Goolagong and King
play Rod Laver,
Terry Holladay and the



MAY

20 Thu. NEW YORK: Billie Jean King, Virginia Wade, Fred Stolle
22 Sat. PITTSBURGH: Evonne Goolagong, Mark Cox, Vitas Gerulaitis
24 Mon. LOS ANGELES: Rosie Casals, Bob Lutz, Dennis Ralston
27 Thu. PHOENIX: Chris Evert, Tony Roche, Kris Kemmer-Shaw
29 Sat. GOLDEN GATERS: Frew McMillian, Tom Okker, Betty Stove

JUNE

8 Tues. BOSTON: John Alexander, Greer (Cat) Stevens, Kerry Melville
10 Thu. PHOENIX: Chris Evert, Tony Roche, Kris Kemmer-Shaw
12 Sat. CLEVELAND: Marty Riessen, Martina Navratilova, Rayni Fox

JULY

6 Tues. CLEVELAND: Marty Riessen, Martina Navratilova, Rayni Fox
22 Thu. BOSTON: John Alexander, Greer (Cat) Stevens, Kerry Melville
23 Fri. INDIANA: Allan Stone, Carrie Meyer, Ray Ruffels
25 Sun. LOS ANGELES: Rosie Casals, Bob Lutz, Dennis Ralston
26 Mon. NEW YORK: Billie Jean King, Virginia Wade, Fred Stolle

AUGUST

7 Sat. PHOENIX: Chris Evert, Tony Roche, Kris Kemmer-Shaw
8 Sun. GOLDEN GATE: Frew McMillian, Tom Okker, Betty Stove
12 Thu. LOS ANGELES: Rosie Casals, Bob Lutz, Dennis Ralston
14 Sat. HAWAII: Ilie Nastase, Helen Gourlay, Owen Davidson

All matches played at the San Diego Sports Arena beginning at 7:30 p.m.
Phone 298-9855 or 224-4171 for Ticket Information

SAN DIEGO FRIARS

Lion Plaza, Suite 624, 1660 Hotel Circle North, San Diego, CA 92108

Personalized eyewear

Tastefully furnished and equipped to display the finest in fashion eyewear, American and import frames, hard or soft contact lenses. We take great pride in our optical and laboratory work. Please stop by and let Simonne Arnould, master in ophthalmic optics assist you. Special attention to senior citizens. Hearing aid service and sales also available.



Frame of the Month

UNDERGROUND PARKING
(elevator available)

A PROPOS OPTICAL

200 N. Ash

Escondido

46-6221

Mon thru Fri 9:30 to 5:30



Nostalgic.

The historic train depot in the San Francisco Peninsula community of Los Altos was renovated last year to serve as San Diego Federal's office there. It is a nostalgic reminder of the area's heritage... Peninsula communities were spurred by the commuter railroad to San Francisco; and, today, they remain some of the State's most distinctive residential areas.

Los Altos is our second such renovation of an historic site to serve as a savings office; the first was the Heilbron House in Sacramento. San Diego Federal's office network now includes six Northern California communities... Monterey, Santa Cruz, Los Altos, Menlo Park, Sacramento, and Greenhaven.



San Diego Federal
SAVINGS AND LOAN ASSOCIATION

California's family financial center...safe since 1885.

Del Mar
2751 Via de la Valle at San Andres
Telephone: 755-9333

Oceanside
815 Mission Avenue at Clementine
Telephone: 722-1771

San Diego County: Downtown San Diego, Bonita, Borrego Springs, Chula Vista, Clairemont, Coronado, Del Cerro, Del Mar, El Cajon, Fashion Valley, 54th & El Cajon, Grossmont Center, La Jolla, National City, Oceanside, Park & University, Pauma Valley, Point Loma, Rancho Bernardo, San Carlos, San Ysidro, Southeast San Diego. Los Angeles/Orange County: Century City/Beverly Hills, Hollywood, Universal City, Capistrano Beach. Coachella Valley: Palm Springs, Desert Hot Springs, Coachella, Indian Wells, Idyllwild, Rancho California. Northern California: Sacramento, Greenhaven, Los Altos, Menlo Park, Santa Cruz, Monterey.

EDITORS & PUBLISHERS
Ruth and Ralph Giffin

ASSOCIATE EDITOR Rebecca Brown

ART DIRECTOR Phyllis L. Stover

TRAVEL EDITOR Ruth M. Giffin

CONTRIBUTING TRAVEL EDITORS
Choral Pepper, John Haase

SPECIAL CORRESPONDENTS Alice Dutton, Zetta Castle, Don Dedera, Alan Pesin, Troy Reynolds, Irv Grossman, Dave Martin, Richard Donnelly, Boyd Sharp, Tom Gable, Duke Marston, Jeanne Coberly, Louella Liverwurst

PHOTOGRAPHERS Tony Francis, Mike Cowan, Robert Sperry, Jaffarian

ADVERTISING SALES Mary W. Ruhmland, Judy O'Dea, Clay Kemper

NORTH COUNTY LIVING is published monthly by the Village Press. Known office of publication is at 11623 Duenda Road, San Diego, California 92127. Controlled circulation pending. Subscription rate: \$1.00 per copy, \$10 for one year, \$17 for two years, \$23 for three years. \$2 per year additional for foreign postage. Change of address: Six weeks advance notice. Old address as well as new are necessary. General offices are in Rancho Santa Fe, California. Write to North County Living Magazine, Post Office Drawer Q, Rancho Santa Fe, California 92067. The editors assume no responsibility for unsolicited photographs and manuscripts which must be accompanied by a self-addressed, stamped envelope if the material is to be returned. All rights reserved. Reproduction in whole or in part without written permission is prohibited.

ABOUT THE COVER:

Opera's most well-known star comes to San Diego for San Diego Opera's production of Norma. Beverly Sills brings to any production not only her incredible talents, but that special air of excitement that surrounds a star of her magnitude. Helen Isely portrays Ms. Sills in an outstanding article in this issue.

SAN DIEGO'S NORTH COUNTY

Living

MAY 1976 VOLUME 15 NUMBER 5

- 6 Restaurants**
Duke Marston examines two popular North County restaurants
- 10 Beverly Sills**
Opera's diva plays the role of priestess Norma in the San Diego Opera production
- 14 Movies**
Cryptic critic Alan Pesin reports on movies playing around town
- 16 Solary Energy**
The sun may be the solution to our energy problems, but beware the shyster in this popular, burgeoning new industry
- 22 La Costa**
Notes from Zetta Castle on Carlsbad's famous resort
- 24 Horse Shows**
From clothes, to cost, to judges Kristen Tow examines the local horse show scene
- 30 Calendar**
Shakespeare, baseball, jazz, motocross, Southern California Exposition something for everyone in June
- 32 La Jolla**
Alice Dutton focuses on the jewel city
- 34 Travel**
Explore the Mexican Riviera via S.S. Universe Campus by Ruth M. Giffin
- 38 Local get-away guide**
Surfing, picnicking, hiking and climbing... San Diego city and county parks have it all
- 65 Rancho Santa Fe**
A special gazette of Rancho Santa Fe news by Louella Liverwurst
- 77 Business**
Who's who, who's where and what's up in the business world

**Wilhelmy's
Picture Framing**

CUSTOM AND STOCK FRAMES
SHADOW BOXES OVALS
MAT & GLASS CUTTING

Personal attention
to special requests

Tues-Fri 9:30-5:00 Sat. til 4:00
753-8829
1038 N. Hiway 101/Leucadia

**Lomas
Santa Fe
Cleaners**

For those who want the very best

Golf Caps
cleaned free

**TAKE DOWN
& HANG
DRAPERY
SERVICE**

755-2363
Personal & Business
charge accounts welcome

Plaza of The Four Flags
Shopping Center
Solana Beach

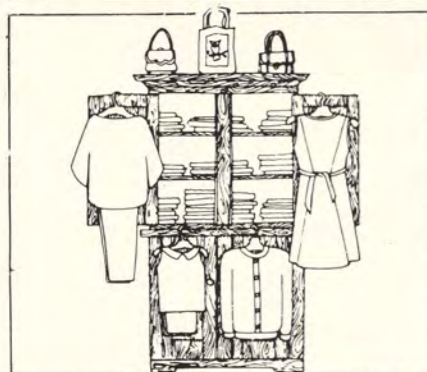

**THE
TWO
GOATS** Traditional Countrywear
for Men and Women
RANCHO SANTA FE, CALIFORNIA - 756-1996

DINING WITH DUKE

by Duke Marston

The continued population growth in the North County has caused the establishment of an increasing number of interesting restaurants.

Rancho Santa Fe is blessed by a small, but well-run operation offering a menu which varies considerably from the norm at both lunch and dinner. *Quimby's*, at Paseo Delicias and La Granada, provides such hard-to-find dishes as freshly prepared seafood quiche and Beef Stroganoff sandwich for lunch. The tossed salads each have a special ingredient of interest and their offering of three homemade soups daily is a welcome find.

One dinner item of special note is the mushrooms stuffed with seafood, a sumptuous dish delightfully sauced with sherried cheese and served in a most generous portion at a very reasonable price. Three grilled fish dishes, and shrimp topped with crab and the aforementioned sherried cheese sauce are the additional seafood dishes offered. Prime Rib or London Broil for the meat lovers complete the dinner entrees. As side dishes, *Quimby's* offers deep-fried vegetables and mushrooms sauteed in garlic butter. The mushrooms are superb.

A limited, but varied and high-quality wine list is very fairly priced at approximately two times wholesale. Beer and full cocktail service are also available.

Service is friendly and competent, though it can be a bit slow at peak periods. This failing is overcome, however, by the pleasant country decor and the variety of available delectables. I did experience a sodden crust on my quiche during one otherwise exemplary meal, but on subsequent occasions have found perfect flakiness.

I cannot complete my discussion of *Quimby's* without mentioning the excellent fruit and cream pies available daily. They are worth saving room for to enjoy their freshness. I anticipate that almost any appetite or taste can be satisfied at *Quimby's*.

One of Escondido's newest restaurants is *The Country Gentleman* which opened in the Vineyard shopping center shortly before Christmas. It is operated by two former managers from the Continental Restaurant System chain. They have taken this experience, plus a desire to provide moderately priced family dining in a warm country inn setting to their new operation, their first as independents.

Prices are extremely reasonable, especially in the beef and beef/seafood combination dishes which have gotten out of hand at so many restaurants. A children's menu is provided to further enhance the family dining concept.

Although the menu leans heavily to the ubiquitous steak, seafood and salad bar menu, several touches separate *The Country Gentleman* from the others. One is the offering of home-style dishes such as Country Pot Roast. Another is the bucket of soup served in addition to the salad bar. A third is the hot deep dish pie, one of the homemade desserts available.

Lunches offer a good variety and prices lower than most similar operations. A fruit, bread and cheese plate may be chosen by the light eater and several beef and seafood entrees and sandwiches, both beef and seafood, make choices difficult unless you eat here several times.

Service has been not only prompt and efficient, but very amiable from the jodhpured waiters, whose uniforms carry out the theme of casual country elegance.

Full cocktail service is provided, although only limited space has been devoted to the cocktail lounge to allow more room for dining.

COCKTAILS

While searching for new restaurants along the coast, I came upon an old building in Encinitas with the word **SALOON** in eighteen-inch letters on the front windows. Intrigued, I went in, only to find a sixty-foot bar running from front to back. It is the largest bar I have seen on the coast. Although the front bar is not original the back bar, of solid wood, dates over forty years to the original operation.

The barmaid set me back briefly when she told me the place was not called the **Saloon**, but rather the **Daley Double**, a name I had seen in a small sign above the front door. The owner, named Daley, simply felt that his spot should be called a saloon (California only recently allowed a liquor establishment to use such a devilish name in description).

The jukebox features everything from Fats Waller (six selections) and the Ink Spots to current popular music. Having been told that the crowd is a healthy mix of young and old I suggest it as a most interesting spot to stop for a cocktail and a little nostalgia.

Next month some outstanding seafood bargains plus more. □



*Caroline
&
Company*
a state of mind

951 Lomas Santa Fe Dr.
Plaza of The Four Flags
755-4061

318 Camino Capistrano,
San Juan Capistrano
714-496-1558

GET HOT WITH COMPASS



THE COMPASS SKIMBOARD

Enjoy your skimboard anywhere there's water and a shore! Any ocean or lake is your playground. Scale your skimboard ahead of you at the water's edge. Jump on! Skim head-on in the narrow water, biding your time until you can ride the face of the next shorebreak. The thinner the water, the greater the acceleration! *You'll glide fifty feet or more with just a little practice — more if the wind is at your back!* It's the newest type of safe, healthful exercise, whether you're five or fifty! Develops balance, coordination and muscle tone while you're having fun!

- Hydro-dynamic design
- 24 inches in diameter
- Weighs only 5½ lbs!

ONLY **\$29⁹⁵**

plus \$2.00 shipping and handling
Calif. residents add 6% tax
International orders, add \$9.00 for air mail.



**Hand-laminated fiberglass
with high density foam core.**

TO:
COMPASS SKIMBOARDS
209 Melrose
Encinitas, Calif. 92024

714/753-0574
DEALER INQUIRIES INVITED



Dear Sir: I've enclosed \$ _____ in check or money order for _____ Compass Skimboard(s) in the color(s) checked below. Please send to:

Name _____
Address _____
City _____
State _____ Zip _____

- Red Blue Green Yellow



THE COMPASS SKATEBOARD

COMPLETE UNIT SKATEBOARDS include sure-grip trucks with roller sport Mark IV wheels. Specify color, design, and whether you prefer 24- or 27-inch kicktail. SKATEBOARD BLANKS include shocks and hardware. Specify color, pattern, kicktail length and drilling. All skateboards have an exclusive waffled deck designed for use with or without shoes.

BLANK ONLY
\$16⁵⁰ SPECIFY DRILLING
BELOW
Plus \$2.00 shipping & handling
Calif. residence add 6% tax
International orders add \$9.00
for Air Mail

\$29⁹⁵ each plus tax
Plus \$2 shipping and handling
Calif. residents add 6% tax
International orders add \$9 for Air Mail

TO:
COMPASS SKATEBOARDS
209 Melrose
Encinitas, Calif. 92024

714/753-0574

DEALER INQUIRIES INVITED

- I want the COMPLETE UNIT
 I want the BLANK only.
(Drilling specified below)

Dear Sir: I've enclosed \$ _____ in check or money order for _____ skateboards or _____ skateboard blank(s) only. Please send to:

Name _____
Address _____
City _____
State _____ Zip _____

- 24-inch Kicktail 27-inch Kicktail

COLOR
 RED
 BLUE
 GREEN
 YELLOW
 WHITE

PATTERN
 FISH
 BOAT
 SCORPION
 CLOUDS
 LIGHTNING

DRILLING
(for blanks only)
 SURE-GRIP
 CHICAGO
 TRACKER
 BENNETT
 X-CALIBER
 BAHNE

You'll find
energy conservation
in the frozen food section
at Safeway.

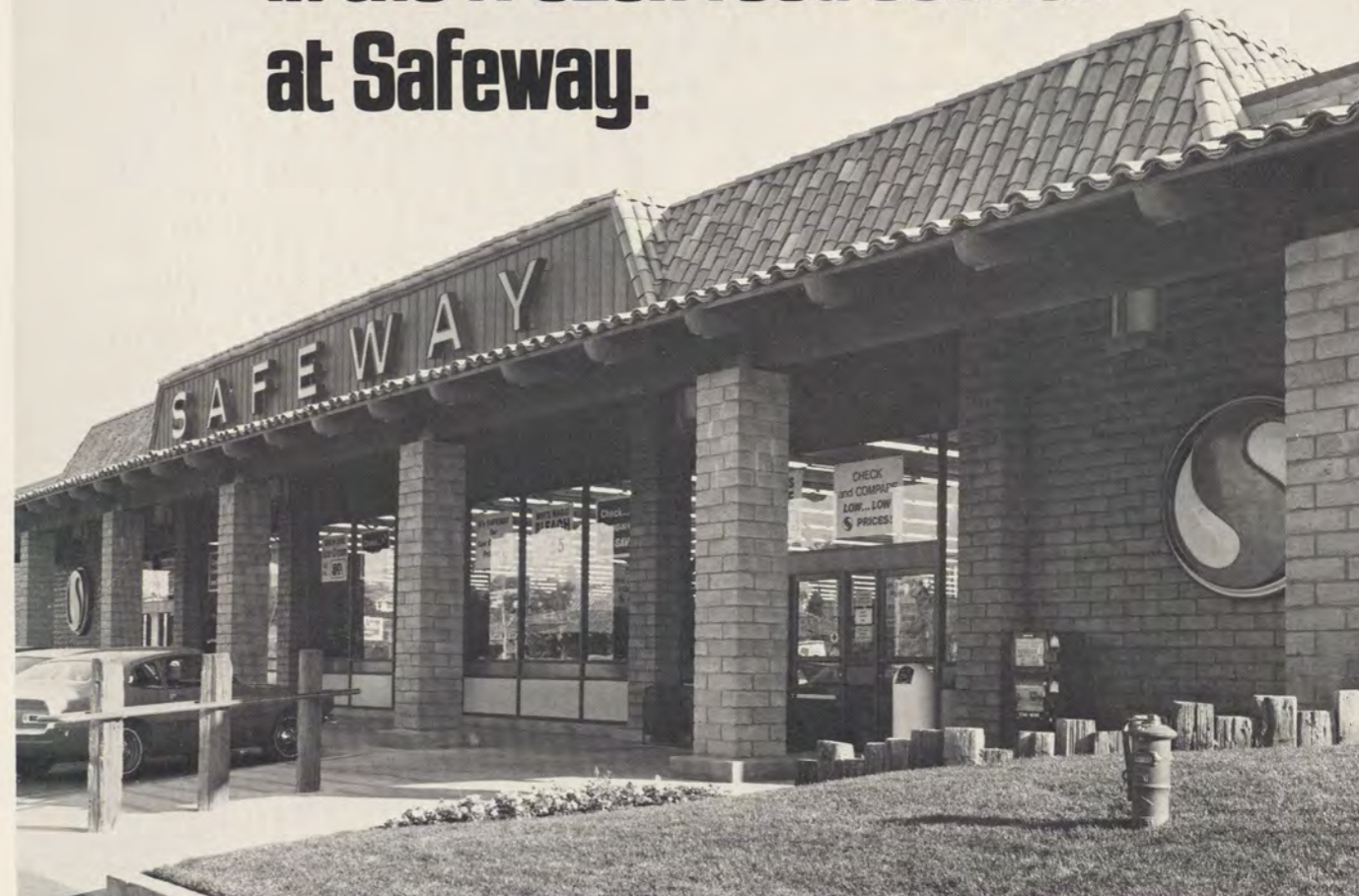

The world's largest grocery chain deals mostly in perishables. So the biggest item on Safeway's energy shopping list is refrigeration and air conditioning. To keep fresh foods fresh. Frozen foods frozen. Customers comfortable. And perishables from perishing.

But the thought of all that cold air has made some avid watt watchers a little hot under the collar. Until they discovered that in many Safeways, the refrigeration system also heats the store!

Here's how it works: refrigeration is not putting cold air into an area. It's taking hot air out. So Safeway simply uses the refrigeration it needs... and circulates extracted heat through the store. The initial capital investment? One

that pays for itself in less than seven years. The result? Hot and cold running energy savings... about 13% since 1973.

Of course, Safeway has also reduced indoor lighting by about 33%. Eliminated most decorative and exterior lighting. Shortened lighting times for parking lots. And controlled new signs with photo cells triggered by darkness.

But most of Safeway's energy savings have come from hot new ideas about recycled refrigeration. The kind of energy saving ideas we've been sharing with San Diego businesses and industries for the past five years... the kind we'd like to pass on to you.

SDG&E SAN DIEGO GAS & ELECTRIC COMPANY

If Safeway can do it, so can you. And we're here to help.

"There's a special pleasure singing in smaller communities, and that is the high degree of excitement the event engenders."

If you are the greatest singing actress of your day, have performed in all the important opera houses in North and South America and in many of Europe's prestigious houses, how do you feel about coming to an off-the-beaten-track city in Southern California to perform? To a beautiful city, but one more noted for sunshine, horse and water-oriented informality than culture? Do you feel as if you are traveling to the boondocks? Not if you are Beverly Sills, who will be in San Diego for four performances of *Norma* and to emcee an opera gala benefit in June.

"There's a special pleasure singing in smaller communities," she said recently in an interview for North County Living, "and that is the high degree of excitement the event engenders." She added, "A community that has numerous art galleries, a permanent symphony orchestra and an established opera company that draws many great singers, designers and conductors cannot be considered the boondocks in any way. In fact, although I've never had a chance to vacation in the San Diego area, I'd love to. When I've been in San Diego I've always had to leave right away for another engagement somewhere else. My daughter Muffie and I did make a complete tour of the San Diego Zoo, but that's all the exploring we've been able to do so far."

When Beverly Sills comes to San Diego in June, it will be her third appearance with the San Diego Opera. Previously she appeared in *Tales of Hoffman* in 1970 and in the *Daughter of the Regiment* in 1973.

Her appearance in June marks a recollaboration of two people who have had spectacular success in previous productions. Tito Capobianco, artistic director for the San Diego Opera, directed the New York City Opera's "Tudor Trilogy," all starring Beverly Sills. In successive years there, beginning with 1970, she sang three Donizetti queens — Elizabeth I (in *Roberto Devereux*), Maria Stuarda and Anna Bolena, all to outstanding critical acclaim.



Tito Capobianco, artistic director of the San Diego Opera, thinks through one of the production problems in *Norma*.

Together Sills and Capobianco will undoubtedly give San Diegans who are lucky enough to be able to get tickets for the new production of *Norma* (scheduled for June 7, 10, 13 and 15) a rousing good show.

Sills first sang the role of Norma for the Opera Company of Boston in 1971. It was a part Sills had wanted to sing ever since her student days, but on the advice of her vocal coach she refrained from tackling the part until she was 40. She was just 50 when she sang Norma in Boston. Since then she has not sung it often — two performances with the New Jersey State opera in 1973 and a concert performance at the Ravinia Festival outside Chicago in 1973. She recorded it on the ABC Treasury Label.

Asked if she was restudying Norma for San Diego, Sills said, "Yes, not only because of the amount of time since I last sang the role, but because it is a role that repays continued study. Norma is a complex woman — a priestess in a very human dilemma, a fascinating character who is the victim of love, guilt and jealousy. The more I study her, the more I find in her."

"Norma is a demanding role, not only vocally but because she is on stage and singing most of the time."

The opera, which is set during the Roman occupation of England and concerns a Druid priestess (Norma), a Roman proconsul and a vestal virgin, is, like many other operas, not notable for its believable story line. Asked if a far-fetched plot ever bothered her, Sills replied, "In the straight play it would. In an opera, no. The music is able to add a dimension to whatever is going on on stage and translate it to another, heightened element, so that the whole thing becomes believable, at least while you're in the theater. The only difference in my approach to Norma from any other role is that I try to have at least a week between it and any other demanding role. And *Norma* is a demanding role, not only vocally but because she is on stage and singing most of the time."

Sills has been quoted as saying, "People should go to the opera to have a good time. I do. I love those three hours on stage." Norma will undoubtedly suffer magnificently, but for all her anguish the joy of doing great work will come through the Sills performance, and San Diego audiences will have a good time.

Sills also expects to have a good time emceeing a fund-raising gala

Beverly Sills in the role of Norma, which she will sing with the San Diego Opera June 7, 10, 13 and 15.

BEVERLY SILLS: OPERA'S HIGH PRIESTESS

By Helen Isely

Open Daily for Breakfast



Solana Beach
937 Lomas Santa Fe Dr.
755-0117

it pays to go
first class



E-Z — GO

Sales — Service
Reconditioned Cars
Accessories

golf
car
center

2312 Vineyard Ave.
Escondido
746-3202

COAST
Brake & Wheel

MUFFLERS BRAKES
WHEEL ALIGNMENT
GOODYEAR TIRES

444 First St., Highway 101
Encinitas, California
753-6272

BEVERLY SILLS

She came, she saw and she will undoubtedly conquer

"Norma is a complex woman . . . a priestess in a very human dilemma, a fascinating character who is the victim of love, guilt and jealousy."



Beverly Sills and her daughter Muffy, 17, at a post-performance party.

to benefit the San Diego Opera June 11. Asked what prompted her to accept the invitation to be the mistress of ceremonies, she said, "I thought it would be fun. And I think it will be."

Beverly Sills is demanding of herself and other professionals, but she is also kind, easy to talk to and is by no means a one-subject singer — vocalizing *mi, mi, mi, mi* all of the time. Something of an accomplishment in itself when you consider that she falls into the category of having been a child prodigy and was performing on a children's radio show at the age of three. She was a regular on the Major Bowes Capitol Family Hour at 12, had a continuing role on "Our Gal Sunday", and also sang the Rinso commercial, "Rinso white, Rinso bright, happy little washday song." Her sensible father demanded that she retire at 12 and attend a regular high school. She later transferred to the Professional Children's school and upon graduation from there at the age of 16, she toured with a Gilbert and Sullivan road company. At 17 she made her operatic debut as Micaela in *Carmen* with the Philadelphia Civic Opera. Then she toured for two seasons with the Charles Wagner Opera Company singing 63 Micaelas and 54 Violettas. In October 1955, she joined the New York City Opera and that has been her base of operation ever since.

Perhaps her naturalness and her lack of the idiosyncrasies sometimes associated with divas is due in part to absolute security in the command of her prodigious vocal

equipment and technique, and also to the fact that her high degree of intelligence is not confined to music. She is not, as is sometimes found in performers, a "one subject genius." She loves the theater, is an omniverous reader, a gourmet cook and a devoted wife and mother. She is the National Chairman of the March of Dimes Mothers' March on Birth Defects and is a member of the Council of the National Endowment for the Arts.

"It was impossible," wrote Martin Bernheimer, music critic for the Los Angeles Times, prior to Beverly Sills' debut at the Metropolitan Opera in 1975, "to pick up any publication other than the telephone book and not read about her." If Bernheimer had been acquainted with San Diego, he would have known that the statement was not quite true. San Diegans had taken Beverly Sills to their hearts prior to that, and placing her with such sacrosanct institutions as the San Diego Zoo and Mission Bay Park, had declared her their own visiting resource for environmental improvement by putting her on the cover of the October 1974 San Diego telephone book.

We are lucky that the lady doesn't mind traveling.

"People should go to the opera to have a good time. I do."

CONSIDER ADOBE . . .

3 important reasons:
beauty, longevity
& ecology



Adobe maintains a constant indoor temperature morning to night . . . winter through summer . . .

Adobe utilizes a non-depletable resource creating harmony with nature . . .

Adobe has been used in home construction for over 5,000 years . . .

Why not consider adobe?



WEIR BROTHERS



THE FINEST NAME IN ADOBE FOR OVER 30 YEARS

28425 COLE GRADE ROAD VALLEY CENTER 714/749-1612

MOVIES ON SCREEN

RANCHO LA PUERTA

Tecate, Baja
California, Mexico

We've Been Thinking About You For Most of Your Life

For over 35 years we've studied the American spa-vacationer. Whether you're overweight, overtense or overtired, our huge spa (½ acre per guest) is planned specifically to make you feel and look better. We know a great spa experience must start with basics: Purest air, fresh natural foods, outdoor exercise. We know our methods work. We know why they do. We're in the spa business and none other. Deborah Szekely Mazzanti, who co-founded and still guides the Rancho, biggest of all major spas, also created...

see opposite page

**weekly Piñata Plan rate
\$450 and up**

Write:
**Rancho La Puerta
Box SD
Tecate, CA 92080
Call (714) 478-5400**

by Alan Pesin



Margaux Hemingway in *Lipstick*. Only her ad agency knows for sure.

Director Martin Scorsese (*Who's That Knocking at My Door*, *Boxcar Bertha*, *Mean Streets*, *Alice Doesn't Live Here Anymore*), in his latest film *Taxi Driver*, withholds viewer empathy from his New York City cab driver protagonist, Robert DeNiro's ex-Marine Travis Bickle.

While modern directors concern themselves with heroes and anti-heroes who are all myth and no substance (Sam Peckinpah's *Killer Elite*, Stanley Donen's *Lucky Lady*, et al); who are always tough, strong, hip, cool, smart, smug, foxy; Scorsese chooses to deal with the denizens of the teeming, lower classes. Scorsese's creations try to scratch and claw their way out of the muck and mire of their social and economic milieus. Ellen Burstyn's Alice tried to be more than a "wife." *Mean Streets'* Harvey Keitel tried to be more than a "waiter." And both failed for their trying; Alice dead in Kristofferson's arms, Keitel dead at the hands of the man he waited upon.

In *Taxi Driver* Scorsese's sewer and scum messiah wants to rid the city of the plagues of cheap sex and easy dope. A driven man, unable to sleep or eat, DeNiro knows he must act. First he

seeks spiritual cleansing in the form of the angelic Cybil Shepherd. Rejected by this solitary pure image in the sea of prostitution, pimps and pornography, the cabbie turns to the salvation of Jodie Foster, thirteen-year-old, working-girl runaway. Along the way DeNiro passes in and out of the lives of Leonard Harris, the presidential candidate and Harvey Keitel, Jodie's Puerto Rican boss and lover.

On the fringes of DeNiro's torments are his fellow cabbies, especially *The Wizard*, Peter Boyle. In a scene reminiscent of Robert Bresson and Bernanos' *Diary of a Country Priest*, DeNiro, like the questing priest, seeks guidance from a more worldly colleague. As in Bernanos' story, the more knowledgeable elder can offer nothing of substance to the questioning novice. Boyle can only help DeNiro live in the city as it is. He has not the imagination to instruct his confused friend on anything but the tricks of the trade as passed on to him by the previous gurus of the business.

Failing at even the simplest expressions of day-to-day living, DeNiro retreats into the confines of his one room apartment. Barren of all spiritual resource save his directionless need to struggle against the vicious slime surrounding him, he moves to discipline his physical self. He organizes his apartment, changes his diet, develops his muscles, trains his responses, and creates from a flaccid, poisoned body, a new self, an avenging angel, an assassin.

A walking arsenal, guns concealed about his arms and legs, he reenters the filth-stained world. DeNiro chooses as his target the politician Leonard Harris. But almost inadvertently, blindly, recklessly, he blasts away to Hell Harvey Keitel and two Keitel business associates.

Incredibly, this mindless rampage results in a hero's write-up in the *Daily News* for the demented killer, and the resulting admiration and envy of the unreachable Cybil Shepherd. Yet he has only succeeded in bringing more violent devastation to the scarred and ravaged inner city.

In attempting to transcend the conditions around him, DeNiro simply mires himself more deeply in them. There is no hope for Travis Bickle.

CURRENTLY SHOWING

All the President's Men — (Grossmont Cinema) — Director Alan Pakula (phones and tapes in *Klute*), cinematographer Gordon Willis (dark and undercover in the *Godfathers*), screenwriter William Goldman (strained rapport in *Butch Cassidy and the Sundance Kid*), Robert Redford, Dustin Hoffman, Jason Robards, et. al, reprise Watergate, *The Washington Post*, Bob Woodward, Carl Bernstein, Ben Bradlee, and the troubled, well-meaning Washington, D.C. of late 1972.

Bad News Bears — (Cinema 21) — Walter Matthau and Tatum O'Neal team together in this strained comedy-satire-sermon about Little League baseball. Director Michael Ritchie loses control of the John Alonzo golden-grainy cinematography, Jerry Fielding's off-key musical score, and Bill Lancaster's over-stated script after the first few innings.

Barry Lyndon — (Valley Circle) — The opening scene is exquisite joy; and Stanley Kubrick's redundancies, marching music playing over and over, reverse zooms receding from close-ups to impressive tableaux, and overabundances of art works in general, are quaint diversions from a narrative which spans three hours and four minutes and the life of an Eighteenth Century Irishman.

Dog Day Afternoon — Droll hysterics followed by muddled seriousness. Sydney Lumet has fashioned another Al Pacino solo out of the true story of a bi-sexual bankrobber.

The Duchess and the Dirtwater Fox — (College Theater) — Another misbegotten Hollywood comedy replete with worn-out Mel Frank jokes, worn-out George Segal, and Goldie Hawn, whose attempts at acting wear out her audience.

Family Plot — Director Alfred Hitchcock and scriptwriter Ernest Lehman (*North by Northwest*) have reduced Hitchcock's previous fifty or so films into this shaggy dog kidnapping film starring Bruce Dern, Karen Black, Barbara Harris, and William Devane. Every scene in the film reminds one of Hitchcock past, not an unpleasant experience.

Gator — Burt Reynolds stars and directs this pseudo-action-farce about corruption in a Southern town. Lauren Hutton's liberationist reporter falls head over heels for Burt, but their affair is stymied by a beckoning Walter Cronkite.

Lipstick — (Fashion Valley) — A big issue well-handled by little minds. Are a model's public seductions (i.e. her advertisements) invitations to private molestations? Only her ad agency knows for sure. Margaux Hemingway in her debut performance directed by Lamont Johnson.

Next Stop Greenwich Village — (College Theater) — Paul Mazursky's humorously, autobiographical attempt to recreate his life in the radically independent Village of the early Fifties.

One Flew Over the Cuckoo's Nest — (Cinerama) — Milos Forman captures the mood of the Ken Kesey novel without sacrificing the cinematic possibilities. Jack Nicholson plays R. P. MacMurphy playing Jack Nicholson.

W. C. Fields and Me — (Loma Theater) — Arthur Hiller (*Love Story*) directs another Universal biography, this one about the Thirties romance between Fields and Carlotta Monti. Rod Steiger and Valerie Perrine as the love duo are the consummate mismatch.

THE GOLDEN DOOR

Escondido,
Southern California

We're Offering You \$3½ Million in Fresh Spa Ideas

the gemlike Golden Door, smallest of all luxe spas. The Rancho is rustic, relaxed, rambling, and inexpensive. The Golden Door is small, sylvan, serene and frankly costly. Synthesizing what La Puerta originated—from weight-loss system to dawn-till-dusk daily clock schedule—and enshrining it all in a new spa facility resembling a fine old Japanese inn, The Golden Door now adds many innovative surprises. It is for women only, save for special Men's Weeks. The Rancho is coed. Our spas differ because we understand how people differ.

**\$1,250 per week, plus
15% gratuity**

Write:
**The Golden Door
Box 1567
Escondido, CA 92025
Call (714) 744-5777**

SUN SOLUTION

by
Clay Kemper

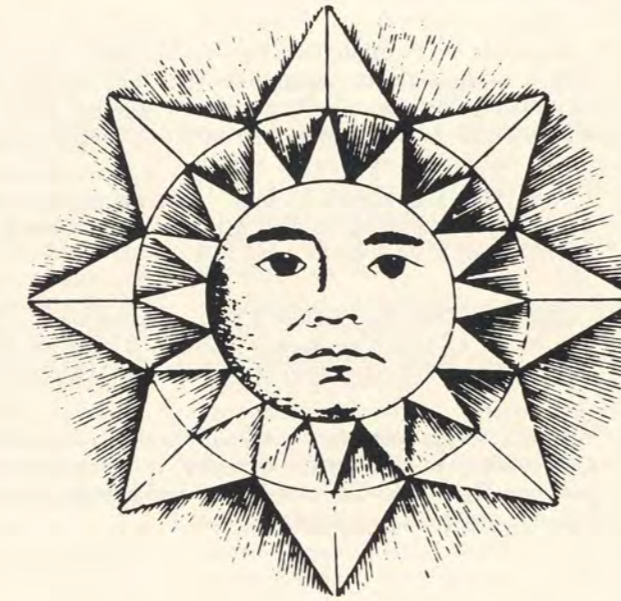
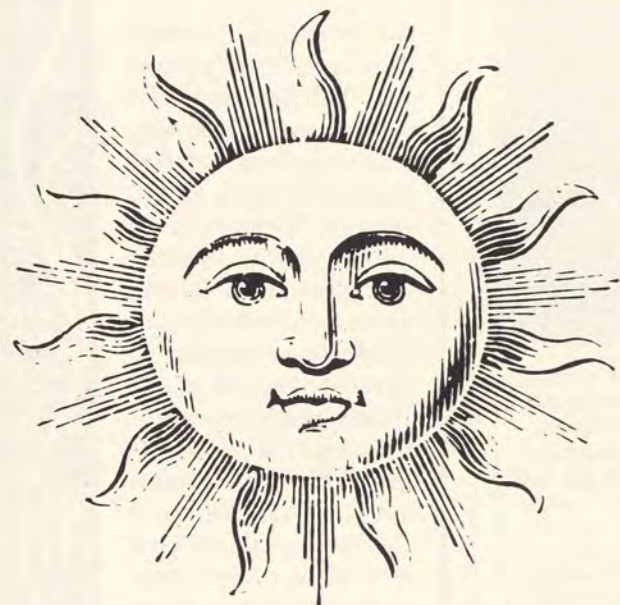
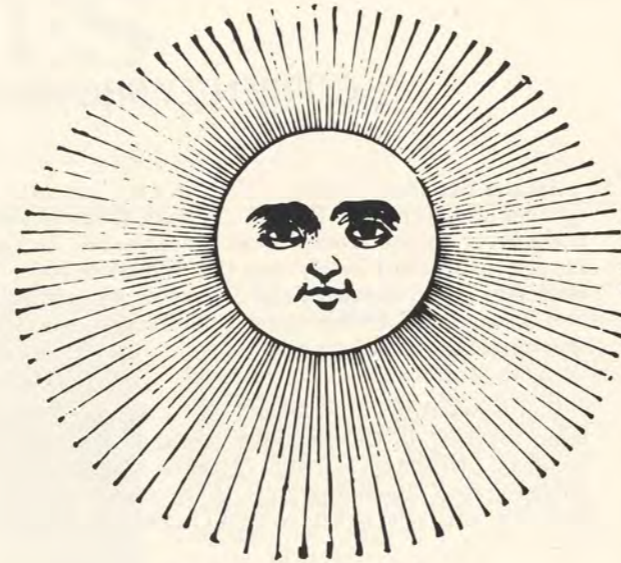

Caveat Emptor . . . let the buyer beware. This old Roman adage was never more important than it is today.

It's a rare week when we fail to hear of someone getting bilked, bamboozled, or hornswoggled out of a small fortune. A little old lady gives up her life savings to a phony bank examiner. The homemaker sympathetically donates cash to a phony charity volunteer. A "Once-in-a-Lifetime" investment company strangely goes out of business after milking down payments from forty speculators. These are but a few ripples on the rising tide of nationwide consumer rip-offs.

Legitimate, good business is still alive and well across the land. Millions of satisfied customers each year will attest to that. But with more than 26,000 new products introduced into the American marketplace each year at a developmental cost in excess of \$6 billion, there are growing opportunities for con artists to invade the competitive free market and make off with some big bucks. Naturally the innocent and the honest suffer the consequences. But do we take heed to the good message "caveat emptor"?

One area that is especially fertile ground for the discerning shyster is that current glamour issue — energy. Faced with gushing oil prices, vanishing fossil fuel supplies, and uncertainty about nuclear safety, it seems logical that Americans begin searching for new, renewable kinds of energy for future needs. Emotions are high. Defenses are weak. These are the favorable conditions for rip-offs.

We Have Options

What are the alternatives for a nation which runs on petroleum? Some urge us, "Get more oil." Others say, "We have more coal than the Middle East has oil. Let's dig it!" A growing number of Americans feel greater emphasis must be given to searches for geothermal resources, coal gasification, harnessing tides or sea swells, nuclear fusion, bioconversion and hydrogen development. Above all, many citizens feel we need merely look skyward — to the sun — for the brightest light in our energy future.

Progress in Solar Development

On a national scale, progress in the development of solar energy has been sluggish but encouraging. Last year, after decades of trying, Congress finally passed the "Solar Heating and

Cooling Demonstration Act" with a five-year, \$50 million appropriation to show the practical application of combined heating and cooling technology.

This fiscal year the new Energy Research and Development Administration separately budgeted an amazing \$88 million for solar research and development, up from practically nothing a couple of years ago. Still, this amount has been called totally inadequate by many experts, including the National Science Foundation. By contrast, 90% of this year's federal energy budget goes toward atomic power and weapons research.

Despite the apparent lack of commitment on the part of the federal government, there are many signs of growing nationwide interest in solar energy. President Ford's new swimming pool is solar heated. Universities are embarking on grandiose research projects. Regional governments, led by Los Angeles County, are in the process of amending building codes to make retrofitting of solar equipment on homes less difficult and costly. Voluntary organizations advocating swifter development of sun power are sprouting up like sunflowers across the country. In fact, San Diego County is one of the most active regions in the U.S. and is home for the Southern California Solar Energy Association (SCSEA), the official Southern California arm of the International Solar Energy Society. (For membership information write to the SCSEA, The Urban Observatory, 202 C Street, San Diego, CA 92101.)

Perhaps the most dramatic indication of the rising interest in tapping the sun's rays is the rapidly growing involvement by such luminescent giants as General Electric, Westinghouse, PG&E, our own SDG&E, several big aircraft and oil companies, and hundreds of small firms into fabrication and marketing of solar stills, pool heaters, water warmers, and space heating and cooling systems.

The expanding involvement by companies large and small is certainly encouraging insofar as our energy future is concerned, but it should also make us more cognizant of the meaning behind caveat emptor.

Practical Applications

Tapping the sun's rays is not something we must patiently look forward to in fifteen, twenty or thirty years.

We're doing it right now! True, direct (photovoltaic) conversion of solar radiation into electricity will not be economically feasible in the near future, but just about anyone in North County can supplement 40% to 60% of his household's energy load with retrofitted solar energy equipment.

According to the Energy Research and Development Administration (ERDA), if 200,000 homes were equipped with solar systems for water and space heating and air conditioning, this country could save the equivalent of more than 14 million barrels of oil annually by 1985.

ERDA's figures indicate that water heating consumes about 4% of our energy, space heating saps another 17.9%, and air conditioning 2.5% more. All of these percentages can be significantly reduced through applications of existing solar technology.

Technological ability unfortunately does not mean economic feasibility. Like any new product, solar power is expensive. Initial capital investment for a single family dwelling of 2,000 square feet can cost in the neighborhood of \$1,300 for a roof top water heating system to about \$11,000 for a sophisticated water and heat pump space heating system that will keep inhabitants comfy through the nastiest of North County winters.

North County Installations

Many areas of North County such as Rancho Santa Fe, San Dieguito, Carlsbad, Valley Center and Del Mar are ideally suited for sun power home units because of substantial yearly sunlight, generally high electrical or propane fuel costs, and their overall high per capita incomes. The high degree of activity in these regions would seem to substantiate such suitability.

Oddly enough, while solar water and pool heaters have been installed throughout the county for quite some time, the first complete solar water and space heating system was christened at the home of Mr. & Mrs. John Beckstrand of Del Mar Heights in December of 1974. The home and solar components were built by Jack Schultz, respected building contractor and president of Solar Utilities Co. of Sorrento Valley.

While not especially unique in outward appearance, the Beckstrand casa is a marvelous example of energy conservation and preparation to maximize the efficiency of the sun system.



The Tom Hawks home, still under construction. Solar panel faces south and is hidden from general view. Photo by Richard Donnelly.



Rooftop solar collector panels at San Diego Gas & Electric Company's demonstration house, 3387 Rancho Miguel Road, Spring Valley. Photo courtesy SDG&E.

Marvin Whaley's pool heating units which failed. Photo by Richard Donnelly.



Fafco pool heating units on the roof of the Dempsey home. Note how well units blend into roof. Photo by Donnelly.



Rooftop solar collector panels at San Diego Gas & Electric Company's demonstration house, 3387 Rancho Miguel Road, Spring Valley. Photo courtesy SDG&E.



The Reginald Paul home, Rancho Santa Fe. Photo by Richard Donnelly.

SUN SOLUTION

Insulation abounds in the floors, walls and ceilings. All windows are double glazed. And the roof top panels have an almost perfectly unobstructed southern face, the ideal setting for best results.

"The entire system is working very well. And I truly appreciate the fact it's maintenance free," owner John Beckstrand proudly stated. "Schultz and I knew we were taking a calculated risk when we decided to go this route when the home was built," he added.

The natural gas back-up system has not had much use due to continued favorable weather and the unit's outstanding performance thus far. It requires several bleak days for the water temperature within the system to fall below 85°F and automatically trigger the back-up burner. SDG&E is carefully monitoring this installation.

Jack Schultz, one of the leading names in our region's solar power industry, believes the reluctance of home owners to purchase large units for heating and cooling is due primarily to the large initial investment and the difficulty in comprehending the long-term benefits versus the gradual rise of their utility bills. "The specialization required for each home plus the capital intensive nature of household sun powered systems generate costs that frighten many people," according to Schultz. "The figures are clear, however, that impressive savings will be realized over the lifetime of the installation," he said. Schultz has been retained by SDG&E and the Sunrise Corporation of Palm Springs to advise in the development of new heating and cooling systems.

Are solar collector panels ugly and obtrusive? Yes, they can be. But to anyone viewing the homes of Mr. and Mrs. Reginald Paul of Rancho Santa Fe or Tom Hawks of Whispering Palms the answer should be a decisive "no!" Both are quite attractive.

The Pauls' home is quite an impressive structure to begin with, like a little Monticello atop a gently sloping knoll in the Ranch. The aesthetically adapted solar panel which unites the southward roof actually seems to accentuate the beauty of this structure.

Featured at this abode is a Lennox heat pump for heating and cooling. Engineering and installation was performed by Jerry Hull, an active solar energy consultant from Leucadia. Materials, fabrication and adaptation was done by the well-established firm, Stillman Heating and Air Conditioning. Jerry and Stillman have teamed up on numerous solar energy projects in North County.

Another one just happens to be the Hawks' residence located on a hidden

hillside not far from Whispering Palms Country Club. This partially completed residence is a model of beauty from the perspective of looks, conservation and practicality.

Tom Hawks, a muscular young fireman, spends almost all his free time working on his fabulous home. He's done most of the work himself, from the masonry steps to the exotic stained glass windows to the classy spiral staircase. Asked why he wanted to install solar heating and cooling he responded by saying, "I wanted to build a nice, comfortable home that demonstrated concern for the environment and energy conservation. It's also nice to know my good investment will pay excellent dividends in coming years," he added.

Part of the investment in his house valued at approximately \$120,000 is nearly \$5,500 worth of glass insulation, special ductwork, separate thermostats and double glazed windows. "Some myopic people might consider him a little dumb for spending that kind of money," says Jerry Hull. "Yeah, he's dumb alright . . . like a fox!" Hull exclaimed.

Tom and Jerry believe that the 2,000 gallon hot water storage tank will be able to provide sufficient hot water for a period of six consecutive overcast days before the back-up system takes over. Even on generally overcast days the collector will absorb about 20% of the diffused solar radiation.

Pool Heating

Perhaps the most efficient and widespread use of solar power at the household level is in heating swimming pools. Being a luxury, many citizens feel swimming pools should only be heated by a non-polluting, renewable energy source, thereby freeing scarce gas supplies for critical needs. Evidently, the California Public Utilities Commission agrees. Its ruling several months ago forbids the delivery of natural gas from a public utility for the purpose of pool heating. This energy conservation measure was to have taken effect on April 1, 1976 but is under appeal. If sustained, the ruling will put solar heating in a very advantageous position.

There are two basic varieties of pool heating collectors — metal and plastic. It's still a matter of debate which is the more desirable. Metal is a superior heat conductor and undoubtedly stands up better to prolonged exposure to direct sunlight. Plastic, on the other hand, is less expensive and less likely to corrode due to the fact it is chemically inert.

Some of the popular names in pool

heating include Burke, Raypac, Sunburst and Fafco. The latter, a plastic unit with a seemingly short one-year guarantee, is the most popular model in the west and possibly in the entire country. Fafco now utilizes a plastic that has undergone 15 years of testing by Dupont on telephone transmission wires. Local distribution is handled by Natural Energy Systems of El Cajon.

One satisfied customer of Fafco is Mrs. John Dempsey of Rancho Santa Fe. "We've enjoyed our pool heater since August of last year," she said as her three big dogs, three horses and cat frolicked nearby. "It actually got so hot we had to turn it off," she added.

Solar pool heating sounds good on paper. But what about the dollars and sense of it? In regions where propane would be the primary fuel source, the dollars and sense of sol power can be very interesting. According to Jerry Hull, "It is not unreasonable to save \$3 per day or \$500 in six months over propane heating in heavy use at a constant temperature." Obviously then, lifetime savings of a sun heater would be extremely significant, especially in view of continually rising fossil fuel costs.

A Failure

If solar energy has sounded just a little too good thus far, be assured that it is not all wine and roses. The neophyte industry has more than its share of troubles, and potential customers must be ever-alert lest they fall victim to a fast-buck huckster.

One notable rip-off took place not too long ago at the home of the Rancho Santa Fe Postal Supervisor, Mr. Marvin Whaley. Mr. Whaley, who had expressed considerable interest in solar heating for his new swimming pool, eventually came face to face with the president of the now-defunct Solardyne Corporation. Typical of many scams Whaley was offered the moon for a song. Total cost was about \$1,150 for the entire system.

He was promised a fantastic 10-year guarantee and unconditional assurance that the pool water temperature would not fall below 72°F. All of these favorable factors, combined with the smooth delivery of the seller convinced Mr. Whaley to take the calculated risk. Unfortunately he lost.

Oddly enough, the downfall of Solardyne's Solarite Pool Heater was not from its inability to maintain a constant 72°F temperature. The system simply fell apart. "It actually worked quite well during the summer. Even got too hot," according to Whaley. After it had been in operation for about three months it began to leak profusely and particles of plastic were breaking off. Whaley's pleas for reparation were met with idle promises. Weeks of in-



SUNSET* GIVES YOU SOMETHING EXTRA!

It pays to be aware of the difference in pool companies. At SUNSET, our Pool Professionals are constantly alert to changes in the pool industry... always ready to offer you the best in service, the best in high performance equipment. Right now, SUNSET offers what we feel is the best pool heater available... the BURKE SOLAR HEATER. Call us today... and we'll tell you why!

OPEN 7 DAYS A WEEK
8 A.M. TO 8 P.M.



**SUNSET
POOLS**

CAL. LIC. # 292317 (C53)

ESCONDIDO

1217-C. E. Valley Pkwy.
(Next to Farrell's in the mall)
Ph. 746-8860

*MERV BAKER:
No. County Manager

SAN DIEGO

5850 Mission Gorge Rd.
Ph. 280-2600

VISTA-OCEANSIDE

Ph. 726-6500

POWAY

Ph. 748-2776

SO. BAY-CHULA VISTA

Ph. 283-5487

SUN SOLUTION



Two 1,500-gallon resin-reinforced fiberglass storage tanks at SDG&E's solar demonstration house. Photo courtesy SDG&E.

action finally prompted him to take legal action against Solardyne. "We won the judgment but still lost the initial investment," Whaley reflected. "I certainly learned a hard lesson. Hopefully others will take careful precautions in knowing the firm they are dealing with and knowing its reliability in meeting realistic guarantees," he concluded.

Consumer Safeguards

While there is no foolproof way to avoid getting bamboozled by an eager slyster, consumer awareness is certainly one of the best assurances.

Mrs. Virginia Knauer, President Ford's chief consumer affairs adviser, believes solar power will result in tremendous savings to consumers providing the industry is developed in a deliberate, well-planned and represented manner. Consumers too have

responsibility. They must voice their concerns and exert their influence in the American marketplace by insisting on dollar value and following common sense precautions before making purchases.

Knauer's office suggests the following list of safeguards that should be followed prior to making a purchase of solar energy equipment:

1. Shop around and compare costs, quality and service.
2. Check the reliability of the firm with which you are dealing. Try to find people who have done business with them and get their reactions. Contact the Better Business Bureau for the company's record.
3. Advice from a competent engineer or architect would be helpful.
4. Demand all equipment perform as advertised. Each installed system

should be accompanied by a detailed written guarantee or warranty. All promises should be written on the contract. Do not rely on oral representations.

5. Make sure you understand all terms on the contract and that it says exactly what you have agreed to. Draw a line through any blank spaces before you sign. Keep a copy of everything you sign.

6. Do not buy solar equipment piecemeal. Deal only with a firm that can provide the entire system. The company will therefore be entirely responsible for its proper function.

7. Educate yourself about consumer fraud and where you can go for help. The City and County of San Diego both have consumer fraud units to assist you.

There is little doubt that the sun will someday be the major direct supplier of this nation's entire energy needs. It's simply a matter of time.

San Diego County, especially North County, can continue to play a leading role in the development of solar energy. Greater cooperation and active interest during the early stages of development on the part of industry, government and the public is essential if we hope to bring home the benefits of a clean, inexhaustible, sunshine future.

Our ever-generous sun will give us her warmth and strength and ask for nothing in return. Let's accept her bountiful generosity. Concern... commitment... and caveat emptor.

The following is a partial list of solar energy companies in the San Diego region:

A. O. Reed & Co., Inc., 4777 Ruffner Road, San Diego 92111.

Natural Energy Systems, 1632 Pioneer Way, El Cajon 92020.

Solar Energy Research Center, Box 17776, San Diego 92117.

Solartec Company, 1203 Sun Valley Road, Solana Beach 92075.

Solar Supply Inc., 7724 Girard Avenue, La Jolla 92037.

Solar Utilities Co., 11401 Sorrento Valley Road, Suite 112, San Diego 92121.

Stillman Heating & Air Conditioning, 1240 North Highway 101, Leucadia 92024.

Sunwater Company, 1112 Pioneer Way, El Cajon 92020.

Wind Power Systems, 4867 Mercury Street, San Diego 92111.

For specific information about solar energy or firms in Southern California, contact the Southern California Solar Energy Association, The Urban Observatory, 202 C Street, San Diego 92101. □

Editor's note: Clay Kemper is the former director of the San Diego Ecology Center.

STILLMAN 753-4583

Lic. #290240

HEATING & AIR CONDITIONING

SPECIALIZING IN

- *SOLAR SPACE HEATING
- *SOLAR POOL HEATING
- *SOLAR WATER HEATING
- *SOLAR AIR CONDITIONING

R.G. "Butch" Stillman

1240 N. Highway 101, Leucadia, Ca. 92024

SAVE \$ USE SOLAR ENERGY



- We have the system to heat your pool.
- Complete water heating, space heating and air conditioning systems.
- Professional engineering services.

NATURAL ENERGY SYSTEMS

"as sure as the sun rises"

1632 Pioneer Way El Cajon
286-4322

the art collector

is now offering
POSTERS!

original art,
exciting graphics,
unique and interesting!
From \$5 and up.



4151 TAYLOR ST., OLD TOWN
Across from Padres Trails Inn
WED.-SUN 10-5:30 299-3232
Member, Professional Picture Framers Association



by Zetta Castle



At the La Costa-IPA Tennis Classic held in March, Mrs. Sid Gillman and Mrs. Walter Zable are intent on action on the court while pretty Karen Zable looks about the crowd. Most spectators were looking at Karen for they were sure she was Chris Evert. Unquestionably, they are look-a-likes.



Bachelor about town, Robert Sommer was seen at the Tennis Classic with Judy Schwam of Beverly Hills.

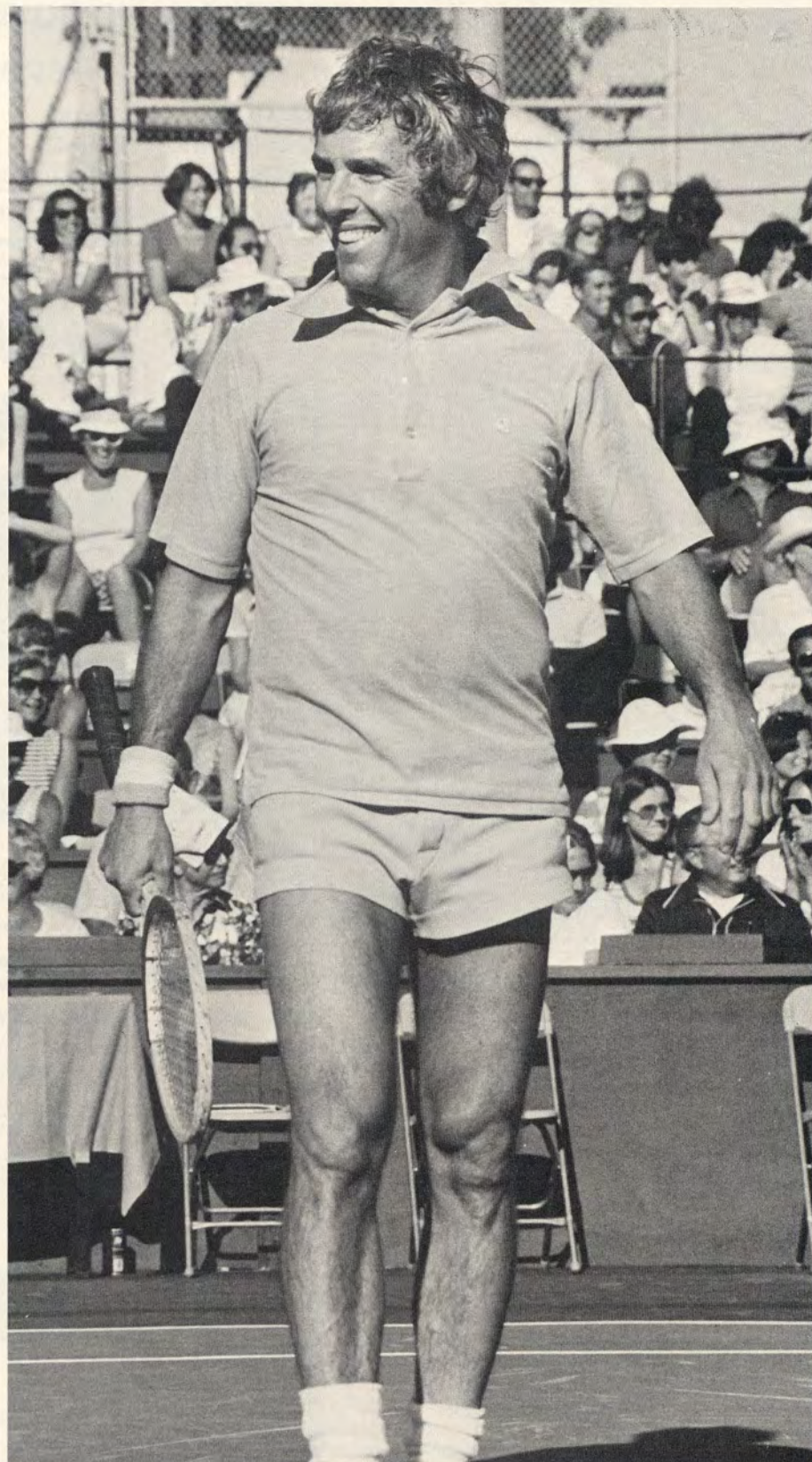

Note the smiles on the ladies' faces as handsome Burt Bacharach strides onto La Costa's Center Court for a Pro-Celeb match during the La Costa-IPA Tennis Classic.



Don Hamilton, La Costa Tournament Director, congratulates Roscoe Tanner on his tennis victory during the recent classic.

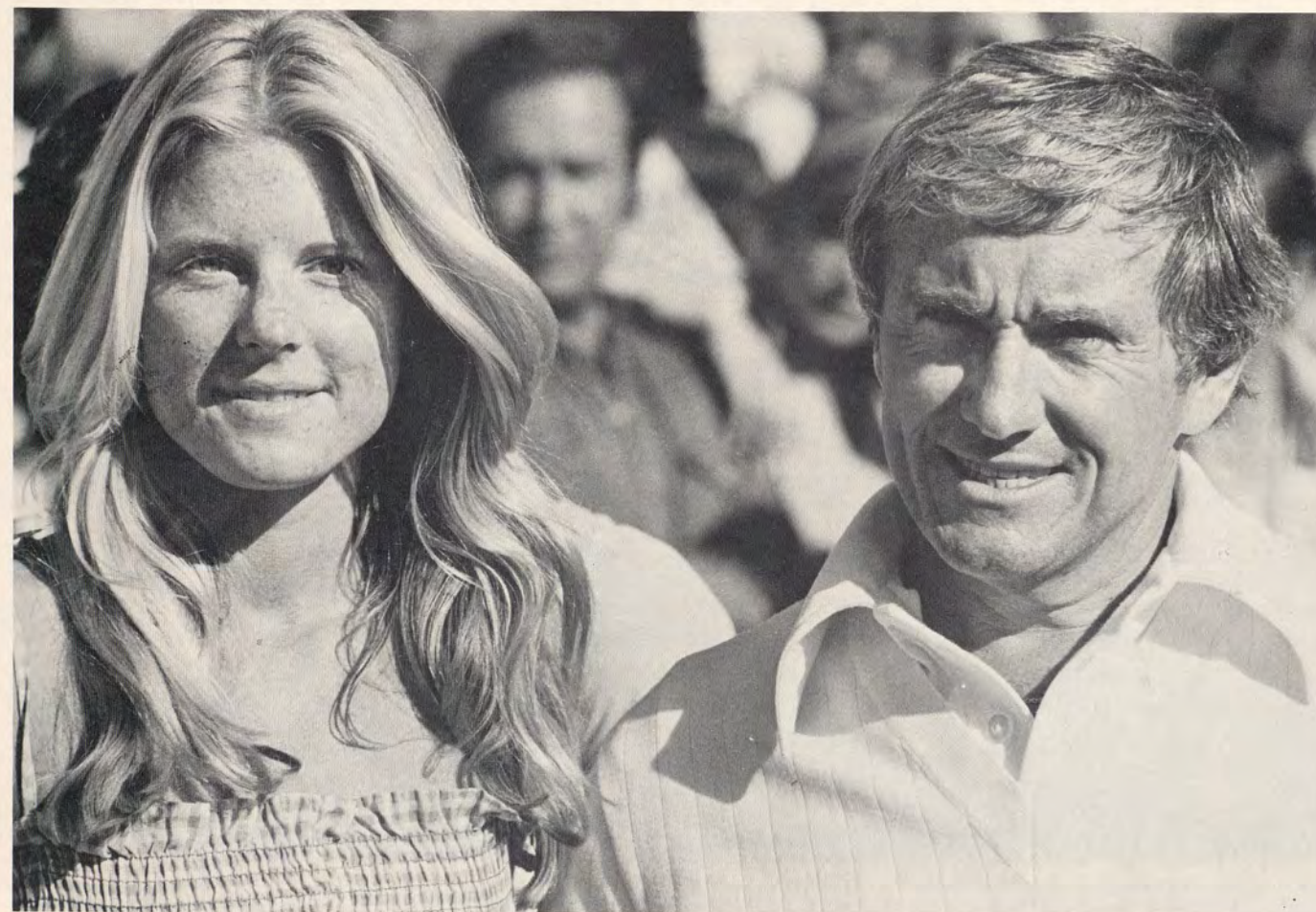

Merv Griffin and a lovely young fan.



Hap Hansen on Magic Mate owned by Mr. and Mrs. Braugher Cowan, Rancho Santa Fe. Shown in one of the many classes of Coto de Caza Winter Classic. Hansen is rider and trainer. Magic Mate is also shown in the junior hunter division by Cathy Cowan.



I've Awakened, owned by Winston Delta Tire Company and R. W. Oliver, shown here winning the Fine Harness Championship Stake at Monterey County Fair National Horse Show. Ridden and trained by Jim McEvoy, I've Awakened also won the \$1,000 Fine Harness Stake at the Southern California Exposition Horse Show and the California Walking Horse Celebration Horse Show.

Horse Show Magic

by Kristin Tow

It starts the day before with laying out clothes, polishing boots, washing, currying, grooming and making the loading list. Then, when the sun is not yet up, the alarm goes off at 4 a.m. and youngsters and adults alike arise to go to the stables for the finishing touches of brushing and braiding, loading the trailer and hitting the road for the day's events.

This is the scene enacted in hundreds of homes and dozens of stables around San Diego County as riders and trainers prepare horses and themselves for a weekend of showing. For ten months out of the year, February through November, the horse show circuit is in full swing bringing out riders and their families to the weekend competitions. Some will take home ribbons or trophies, some will not. But almost without exception everyone will be at another show within a month or two, if not the very next weekend.

Showing horses is only one part of the multi-million dollar horse industry, but it is a facet that is growing in popularity despite the fact that it has always been a very costly sport, and has not escaped the worldwide inflation. Costs for food, bedding, fuel for travel, clothing, and entry fees — not to mention the horses themselves — have gone up dramatically in the past few years. This has forced some riders to cut back on the number of shows and classes they enter, but it has not stopped them from showing altogether. In fact, the number of riders has increased. This means a continuing good business for those who train riders and horses for show.

This influx of new riders into the established horse show community would seem to change the complexion of the crowds. But over the years and across the invisible boundaries within the county, riders are basically the same, be they residents of Lakeside-East County, Bonita-South Bay or Rancho Santa Fe-North County. They are people with a common interest in horses — the challenge of riding and the competition of showing. And, if they are avid showers, active in the ever-expanding and improving San Diego County circuit, they will be associating with the same people countless weekends.

"When you see the same people at these shows you naturally become friendly," said Mrs. Brock (Mary) Cowan of Rancho Santa Fe. Invariably, many of the Cowans' friends are involved in horses.

Mrs. Cowan's family has been involved in hunter/jumper showing for three generations. Her mother, Mrs. Dixon (Helen) Chubbuck rides daily and her two daughters show regularly. Mrs. Cowan, who has been riding since age ten, still takes an occasional pleasure ride, though she has become more involved in show organizations lately.

The Cowans, not unlike many other families, make a fun day's outing of a show. Mr. Cowan, himself not a rider, is the chef in charge of barbecuing, steaking and uncorking the champagne. Fresh fruit and soft drinks are in generous supply. "It really is fun. It somehow gets you hooked so you look forward to the next year," Mrs. Cowan said.

Fun and competition are the words spoken most often whenever riders are asked why they devote so much of their time to training and showing. And in truth the rewards from showing come in achievement rather than in profit dollars in the bank.

"The money that's made in the horse industry is in the breeding," said Lee Sole, saddlebred horse trainer for J.M. Training Stables in Rancho Santa Fe. "People have horses because they like to ride a nice horse, get a certain amount of satisfaction going to the horse shows and associating with people who are interested in horses. It's a hobby."

The Cowan girls, Kathy, 14 and Lynne, 11, gravitated to riding after having been exposed to showing in the family, but just as many people begin riding without any prior experience around horses.

"Kids start riding for fun, then reach a stage at 14 or 15 when they get other things on their minds and give it up. For those who really stick to it, it becomes a way of accomplishment. It becomes a challenge. The satisfaction of saying, 'I can win.' And by that I don't mean first places, but that they are better today than they were yesterday," said John Lipari, owner and head hunter/jumper trainer at La Jolla Farms.

"Many people will see a horse and know at the time that it is more than they can cope with, but it's a challenge to them. The average person is trying to perfect not only the horse but his or her ability to make the horse perform to its utmost," Sole said.

"It's a good thing for young riders because it teaches them responsibility. If they are working with their horses and around the barn then they aren't out

getting into trouble," said Mariel Hannay, quarterhorse trainer at Mt. Carmel Valley Ranch in Del Mar. "They learn to win and lose gracefully."

Anyone who just wants to have a backyard horse and take an occasional pleasure ride along the beach or on a back country trail can learn the basics at almost any age. But in order to be a serious contender on the show circuit one should begin riding as a child. Most trainers agree that seven or eight is a reasonable age to begin. Even younger children can start lessons, but until the age of ten or so they have limited attention spans.

"The younger they start, the braver they are," said Dianne Grod, hunter/jumper trainer at Rancho Bernardo Saddle Club. "They trust you a lot more and think, 'If she thinks I can do it then I can.'"

"I really believe that people who are just getting started, if they just want to learn the basics, should try group lessons to see if they are really interested. Then I think private lessons are the only way to go," she said.

Grod, who has been training in California since coming here from Maryland ten years ago, firmly believes that individual help is the best way to produce a good rider. At the present time she has only eight students and likes to keep the number small.

San Diego County has more horses per capita than any other county in the country. It is different in another respect — the California Professional Horsemen's Association (CPHA) Chapter 1 has its own show circuit here. To be a CPHA-rated "A" or "C" show strict criteria must be met regarding the list of classes held, how much prize money will be awarded, having approved judges, and so forth. There are nine "A" shows this year; "A" riders are those good enough to compete anywhere, including the larger shows in Del Mar, Santa Barbara, Monterey, Indio and in other states. "C" riders are beginners in their first or second year of training. Novice or "pregreen" horses are also shown at "C" shows.

"We can really get someone ready before we take them to an "A" show. "C" shows give them a good idea of what it means to show," Lipari said.

After that competitive urge is sparked through the beginners shows there is another invaluable trait that must come into play. "Even more than competitiveness, it takes an extreme

Horse Show Magic

amount of self-discipline to be successful," Grod said. "I can name a dozen kids I've worked with who had the ability, but just didn't have the self-discipline."

Constant time and energy must be devoted to getting ready to show. A person must learn to ride well, a horse must be taught what to do, and then the rider and horse must learn to work together as a team. But Grod and many other trainers do not advocate the owner being the only person to ride a particular horse. That only increases the chances of the horse picking up bad habits from a rider who may not even be aware that an improper movement is developing.

This is when having both rider and horse under the supervision of a trainer becomes particularly important. "Usually those who stick with showing and aren't with a trainer end up in training because they're not doing as well as those who are in training," said Jim McEvoy, Rancho Riding Club saddlebred trainer.

THE RIGHT TRAINER

Shopping for a trainer can be a hit or miss proposition if not done carefully — and a miss can be costly both in terms of money and improper background for the beginner. Trainers are not licensed, so anyone can hang out a shingle. There is a bill pending in the Senate to make licensing mandatory, but in the meantime CPHA has taken steps to aid the amateur looking for an expert. Last year the organization established an apprentice program whereby an aspiring trainer works under the watchful eye of a CPHA member, progressing from the "B" level to being an "A" trainer. CPHA's referral service will furnish names of "A" trainers in a rider's vicinity.

Less capable trainers may have thought that the preponderance of horses in San Diego County would mean a gold mine for them, but it has also meant that there is a concentration of excellent trainers here.

"There used to be many more bad trainers here, but the shows have improved and they just couldn't compete. That's what we're working toward: improving the shows so it takes a better horse to win," Grod said.

"There are always some bad apples, but those things usually take care of themselves. Fly-by-night operators don't last long," said Sole, a member of the United Horse Trainers' Association. Both that group and CPHA are actively working on legislative and internal means of policing the profession.

26 / MAY 1976

Aside from CPHA referral, an amateur should also go to shows, watch trainers there and at their stables (if they are public), ask about trainers, look at records and how they work their horses, and find out if that trainer travels the circuit the individual wants and can afford to follow.

A trainer is a professional who is paid for his or her experience, talent, knowledge and intuition about how to adjust training to an individual horse. The frequency and length of work-outs vary according to horse, rider and goals for both.

"Some horses are better when worked daily; some every other day. Younger horses need repetition to learn; older ones already know what they are to do and only need to be kept in condition so they can show well and not run out of energy mid-show," McEvoy said.

This is true for all horses, but saddlebreds in particular must be under the constant supervision of a trainer, according to Sole, who has been in the business 40 years. "Because there are five different gaits for them, it's only a matter of two or three days for them to get into a bad habit." From there it can take weeks to correct the mistake.

Among the dozens of stables in the county there are many where the beginner can try out this new experience of riding on one of the stable's veteran horses. The rider who continues to the show circuit begins thinking of owning a horse. About half of the "C" riders own their own horses and it's unusual to find an "A" rider who doesn't own his/her own horse.

Grod only accepts students who have their own horse(s). "I'm against people getting started in the horse business in showing if they don't realize the financial responsibility," she said. "You should have put a lot of money into lessons before you shop for a horse. Obviously, your first horse isn't going to last you after you've learned more. It takes a lot of horses to get to the one that you finally want to end up with."

Shopping for a horse means fitting the rider's ability and show goals with a horse's temperament, conformation and training. Of course, another route is to buy a horse as an investment and have it trained and shown by a professional. Either way, there are few if any bargains to be found.

NO SMALL PRICE TAG

For a thoroughbred show horse of open-class winning quality the price tag will run about \$20,000, according to Hap Hansen, hunter/jumper trainer at Rancho Riding Club. A nice, average

horse can be had for \$5-\$10,000. Less than \$5,000 will give you a backyard horse for pleasure riding.

"A horse represents a considerable investment. A top-quality American saddlebred costs around \$25-\$75,000. You can buy a horse for less than that, but it usually isn't competitive for the top three monies at the major national horse shows. The mediocre horse — less than \$5,000 — is hard to sell at the present time," Sole said.

Generally horse sales are slow the first quarter of the year when people are paying off holiday bills and steeling themselves for the April 15 payments. The most marked affect the recession has had is that the market is glutted with the \$2,500 horse and there aren't enough good \$10,000 horses, according to Lipari.

The purchase price is only the beginning. Whether the horse is seasoned or green (unless it is to be a backyard horse) it still needs boarding and training. Together those can run \$185-\$270 a month, and up, without the expenses of trailering to shows, special grooming, shoeing, day charges for trainers when at shows, entry fees etc. The "et cetera" can include grooming aids — shampoos, conditioners, brushes, hoof picks, insect repellent, blankets — and veterinary care.

Now that the "naked" horse is clean, healthy, fed and exercised, it is ready for all the equipment necessary for showing, and the rider for clothing. Tack for English riding runs in the neighborhood of \$500 and up (saddle plus fittings), bridle and kit, \$45-\$150 plus, and full riding habit adds up to about \$220 (if you aren't handy with a needle and thread). If there is a junior rider in the family, be prepared to keep buying boots and clothing as they grow into bigger sizes. A savings can be found by getting used boots and clothing — often "used" means worn only a few times.

While English has gotten the reputation of being the elite riding style, perhaps from visions of Easterners and Britons riding to the hounds, it is actually more expensive to outfit a horse for the Western circuit. A quality show saddle with the obligatory silver starts at about \$700, and bridle, bit and reins will run another \$600. The price goes up proportionate to the amount of silver added.

Used saddles are slightly less expensive and preferred by many riders because they have already been broken in and thus are more supple. Western attire from hat to boots can cost an average of \$150. The prices quoted above for "tack 'n togs" are average base prices for show quality merchandise. Customizing any of the above items will, of course, take the price up.

APPEARANCE COUNTS

Now that horse and rider are matched, outfitted and trained, they are ready to be judged on performance and appearance at the show. Lest anyone think that appearance is an insignificant part of showing, he need only ask a trainer. Almost without exception they will affirm the importance of being well turned-out.

"I believe 100 percent that any horse and rider should be properly turned-out," said Grod, who judges horse shows. "A horse and rider that are properly presented show me that they really take an interest in what they are doing. It's not a credit if they stand out in a large class because they're poorly turned-out."

"A judge makes up his mind when the rider comes into the ring. Dress is not what makes a winner, but a rider has to be turned-out properly to be a winner," Lipari said.

"You can take a nice rider and put him in the ring in bad clothes and he'll be completely overlooked," Hansen said.

"Anything you can do to enhance a horse is very important," said Sole, who also is a judge. McEvoy speaks in terms of an overall picture where rider and horse compliment each other to make a good showing.

That concept was reflected by Hannay who noted that a rider and horse who are not neat and clean will probably lack in other respects, whereas the people who know enough about showing to do well also know that the better the horse is and the better horse and rider look, the greater the chances of winning.

"When you go to a horse show it's for that judge's opinion, that's what you went for, and 99.9 percent of judges are anxious to do a good job," Sole said.

A QUESTION OF HONESTY

There are whispers of discontent about the fairness of horse show judging and the affect of behind-the-scenes politicking, but most trainers state unequivocally that there is not blatant prejudicing (bribery) involved.

"Judges are under a lot of pressure. They try to be honest and they are honest, but showing is like anything else — it becomes a fad. You get a top-name horse and a top-rated trainer and the judges figure they can't go wrong if they go along," Lipari said.

The American Horse Show Association (AHSA) licenses judges. Just as with less capable trainers, the less qualified judges will find themselves out in the cold. "According to the rules, an individual who isn't asked to judge a show for three years automatically loses his judge's card," Sole said.

In addition, there are strict regulations. "Any obvious maneuvers one



Dianne Grod on Speculation owned by Dr. Donald Thurston.

Lubach's

*"Everything you'd like
a restaurant to be"*

Hawthorn at the Waterfront
Noon till Midnight
Closed Sundays & Holidays

232-5129

Winner of Holiday Magazine Award

On the ocean
for boys 7-17

CAMP PACIFIC

June 27 — August 7, six or three weeks of fun, including a varied sports program to suit every boy. Individually planned academic study available in six-week program. Member ACA and WAIC.

Write or call for catalog
CAMP PACIFIC
Box L
Carlsbad, CA. 92008
714-729-2385

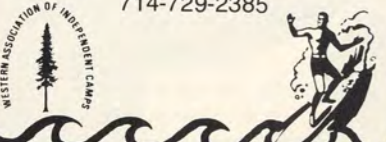

SOLANA CARPET CLEANERS

For the Finest in Professional Cleaning

NEW JET "STEAM" AND EXTRACTION METHOD
The First Of Its Kind On The West Coast

- Deep-Down Steam Cleaning
- Doesn't Soak Carpets
- Extracts Embedded Grit & Soil
- Restores Carpeting
- Lifts Pile
- Brightens Colors
- Sanitizes, Deodorizes
- Soil Retarding

**ALL IN ONE
GENTLE
ACTION
NO
BRUSHES**

The Most Complete Steam Cleaner
On The Market Today

Call Your Local Cleaner
Lower Prices . . . Quality Work **753-2511**



Julie Taylor of Bonita on her thoroughbred Sweet Lime, shown jumping at the Bishop's Schools Horse Show at Rancho Bernardo Saddle Club in March. She won the ONODARKA Hunter Seat Medal Class, riders 12 and under, and Junior Working Hunters, 11 and under, on Sweet Lime. She won that last class on her horse Joe Cool. Julie trains with Dianne Grod.



Jim McEvoy on Hillsrest Commander at Rancho Riding Club's June 1975 show. Owned by Winston Delta Tire Company and R. W. Oliver of Glendale and Rancho Santa Fe. Reserve champion on the Five Gaited Stake at the show. McEvoy was rider and trainer.

way or the other are handled quickly," Grod said. Yet, she noted, "I will admit that a name trainer who has consistently shown winning horses and has a good reputation, is a good rider and shows quality horses will get the benefit of a doubt."

There are riders who, if they have repeatedly not placed well with a certain judge, will just not enter that show. It's the responsibility of show organizers to book judges, and they try hard to bring the best from other parts of California and from other states to minimize the "fad" aspect. And, if it's a serious rider who goes to most or all of the shows on a particular circuit, the varying opinions of judges will usually even out in the end when the year's points are totaled.

But, the judges are not the only ones under pressure come show time. Riders, through their own competitive zeal or that of their parents, are also on the spot. Every trainer can tell stories about the good riders who gave up showing because of the pressure from point-happy parents.

"A lot of good, juvenile show riders quit because they get good then the parents don't think there's any reason why they shouldn't always be first. Then they go to pushing the kids and the kids decide 'No matter how much I enjoy it, I'm not going to take the pressure,'" McEvoy said. "I had a student who had to skip her senior prom to go to a horse show. It wasn't her idea — she wanted to go to the prom."

"When parents are very pushy the kids turn out unnatural because they are more worried about what their parents are going to think than about how well they are riding," Hansen said.

Grod tells about one girl whose parents were point-happy when she was 13 and not winning anything. They gave up the quest for points and at age 15-16 the student started winning frequently. "Then the parents wanted to go for points again. As soon as they decided that, and we began to go to special shows just for the points, she rode terribly. She started resenting other kids in the barn when they won. Also, you wear out your horses that way,"

she said.

For a young person, riding can be a valuable and rewarding experience if handled properly. Lipari, who has had his share of the pushy parents in his 10-year career, finds that the easiest age group to work with is 14 to 19-year-olds. "They are the most attentive and try the hardest, whereas in other things, at home and school, they are the most difficult age group. But in showing they've found a real world that applies to today, not ten years from now. It gives them a sense of identity amid the confusion of growing up. They say 'I can see the fruits of my work right there.' They have the satis-

faction of finally winning after persevering through defeats and long hours of work. They can't get big-headed because they worked too hard to get there.

"Riding gives them a goal. It's a means to an end; it's not the end," he said. Perhaps therein lies the secret to the popularity of showing horses. This is why people put in countless hours of practice, spend thousands of dollars and lose sleep to get ready for that first early morning show class. And when the day is done, it's time to stow the gear, wrap horses' legs, load the trailer and go home . . . eagerly awaiting the next show. □

ASID

American Society of Interior Designers

is the only national
organization
of professional
interior designers



Members of the San Diego
chapter are supporting
preservation in your
community.

Attend
The Designer's Auction May 9 at 1 P.M.
The Showcase House
1865 Sefton Place/San Diego

SUNDAY

MONDAY

TUESDAY

WEDNESDAY

THURSDAY

FRIDAY

SATURDAY

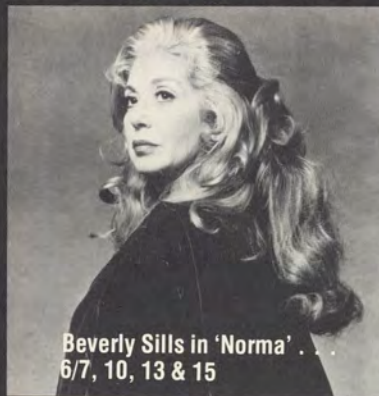

Beverly Sills in 'Norma' . . . 6/7, 10, 13 & 15



Southern California Exposition . . . opens 6/22

1

"As You Like It" Opens tonight at Old Globe Theater Balboa Park
Atomic Cafe Experimental Music 8 p.m. Mandeville Recital Hall UCSD
McCoy Tyner Jazz at the Catamaran 3999 Mission Boulevard Through Sunday

2

UCSD Concert Choir & Chamber Singers UCSD Mandeville Recital Hall 8 p.m.
Expo '76 Family Fun Fair Sports Arena Through Sunday
Rest of the Fair Pageant Al Bahr Temple 5440 Kearny Mesa Rd. 7 p.m.

3

4

"Sweet Charity" MiraCosta College Reservations 757-2121 ext. 51 Through Saturday
Leon Russell Golden Hall 8 p.m.

5

Chinese Music Concert UCSD Mandeville Recital Hall 8 p.m.
Paintings, collages and prints Knowles Art Center 7420 Girard — La Jolla

6

161st Corpus Christi Fiesta Mission San Antonio de Pala Pala 9:30-5:30
Contrabass Recital Mel Graves UCSD Mandeville Recital Hall 8 p.m.

7

"Norma" San Diego Opera production with Beverly Sills Civic Theatre 8 p.m. — 6/7 & 10 2:30 p.m. — 6/13 7 p.m. — 6/15
Gail Zumstein & Chamber Music UCSD Mandeville Recital Hall 8 p.m.

8

"Othello" Opens tonight at Old Globe Theatre Balboa Park
Friars vs. Boston World Team Tennis Sports Arena 7:30 p.m.
Padres vs. New York San Diego Stadium Through Thursday 7 p.m.

9

Kenny Burrell Jazz at the Catamaran 3999 Mission Boulevard Through Sunday
Kids, take heed! First copyrighted book was a spelling book The Philadelphia Spelling Book 1790

10

Friars vs. Phoenix World Team Tennis Sports Arena 7:30 p.m.

11

Opera Fanfare '76 San Diego Opera dinner/dance benefit Mistress of Ceremonies — Beverly Sills
Padres vs. Philadelphia San Diego Stadium 7 p.m. — 6/11 6 p.m. — 6/12 1 p.m. — 6/13
"Redcoats and Patriots" Bicentennial drama Patio Playhouse — Escondido 8 p.m. — Fri. & Sat. thru 6/26 2 p.m. — 6/13 & 20

12

"Naives & Visionaries" American folk art La Jolla Museum of Contemporary Art 700 Prospect Through July 25
Friars vs. Cleveland World Team Tennis Sports Arena 7:30 p.m.

13

Gordon Jennings Memorial Race Powerboat race on Mission Bay East Vacation Isle 9 a.m. - 5 p.m.
UCSD Graduation UCSD Campus

14

Flag Day
Padres vs. Montreal San Diego Stadium 7 p.m. — 6/14 & 15 1 p.m. — 6/16

15

Ahmad Jamal Jazz at the Catamaran 3999 Mission Boulevard Through Sunday
A kite . . . and a key? 1752 — Ben Franklin demonstrated relationship between lightning & electricity

16

Carnation Festival & Starving Artists Show Horton Plaza — Downtown San Diego Free carnations Through Saturday
An Evening with Keith Jarrett Civic Theatre 8 p.m.

17

"Our Sun, The Star" Reuben H. Fleet Space Theatre Balboa Park Open run 238-1168 for showtimes

18

Scripps Clinic Invitational Golf Lomas Santa Fe golf course Solana Beach

19

Don't forget Dad 1910 — Father's Day first celebrated in Spokane, WA

20

Father's Day
U.S. Grand Prix Motocross Carlsbad Through Tuesday
"Sounds of America" Virginia Cox, organist First Presbyterian Church 320 Date St. 7:30 p.m.

21

Palomar Mountain Ride Sponsored by Vista Palomar Riders 724-4865 for brochure Through Friday
Padres vs. San Francisco San Diego Stadium 7 p.m. — 6/21 & 22

22

Come to the Fair! Southern California Exposition Opens Del Mar Fairgrounds Through July 5 9 a.m. — midnight

23

"Rivers of North America" Reuben H. Fleet Space Theatre Balboa Park Open run

24

Stanley Turrentine Jazz at the Catamaran 3999 Mission Boulevard Through Sunday

25

Padres vs. Atlanta San Diego Stadium 7 p.m. — 6/25 6 p.m. — 6/26 doubleheader 1 p.m. — 6/27

26

Old San Diego Art Fiesta Old Town State Park Through Sunday

27

Can't wait for Del Mar? Thoroughbred racing Caliente Race Track Tijuana 1-6 p.m. — Sat. & Sun.

28

Padres vs. Cincinnati San Diego Stadium 7 p.m. — 6/28, 29 & 30

29

Jai Alai Pari-mutuel betting Fronton Palacio Ave. Revolucion at Calle 7a Tijuana 8 p.m. daily except Thursdays



Rod Laver and World Team Tennis . . . 6/8 &

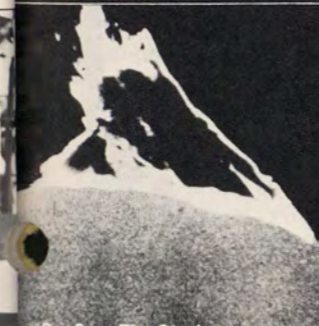

"Our Sun, The Star" open run at Space Theatre

JUNE CALENDAR

LA JOLLA SOCIAL SCENE

by Alice Dutton

Lovely lensible ladies of La Jolla are making the month of May merry with many benefits for worthy causes before June graduations and summer festivities begin.



Helen Anne Bunn of San Diego, center, entertains often for worthy projects, but this was a fun party held in the Seahorse Room adjoining the Marine and Spindrift Rooms. Two of Mrs. Bunn's guests were Mrs. Jack Lewis Powell left, and Mrs. Roland Sahm of Rancho Santa Fe.



At the home of Mr. and Mrs. James H. Knox an equally gala "Stirrup Cup" party was held preceding The Bishop's Schools annual horse show at Rancho Bernardo. Among almost 100 guests were, from left, Richard B. Huntington, trustee; Mrs. Huntington; Miss Dorothy Anne Williams, school headmistress, and Joseph Beagin. The horse show was a benefit for schools' projects.

32 / MAY 1976



Among new officers of the Women's Association for the Salk Institute who were elected at a meeting at La Jolla Beach and Tennis Club were l. to r. Mrs. Bernard Meade, La Costa, executive vice-president; Mrs. Harriet Mons Willie, La Jolla, outgoing president, and Mrs. Amos Sommers, Rancho Santa Fe, 1976-77 WASI president.



For La Jolla Social Service League's main project — League House, a home for elderly women of limited means — Angela Talbot will present an evening of "Songs of the Federal Period" at Sherwood Hall May 28. Mrs. De Witt H. Merriam La Jolla, is chairman of the event. Mrs. Talbot is the wife of John W. Talbot of La Jolla and the daughter of Dr. Augustus B. Kinzel, also of La Jolla. One of Mrs. Talbot's many successful performances was given at famed Carnegie Hall.



Looking ahead to summer are these tennis-minded individuals who are planning the annual Bishop's Schools' Tennis Camp, June 13 to August 21. From left, members of the advisory committee: Back row, Frank M. Bryant, admissions director; Miss Dorothy Anne Williams, school headmistress; Joseph H. Wesson III, tennis camp director, and Mrs. James H. Knox, trustee. Front row, Ralph L. Trembley, sports writer and publicist; William Scripps Kellogg, and Alex Gordon, tennis professional.



When La Jolla Opera Guild members completed their two-month Bridge Marathon in the Marine Room at La Jolla Beach and Tennis Club, Hazel H. Mang and Carsten Volquartz of Solana Beach, third and fourth from the left, won the first prize, while Billie Evans and Virginia Nelson at right, were second. The foursome were congratulated by Edgar Wortman, bridge director. Mrs. George Read of San Diego was event chairman and Mrs. Leon Wheatley of La Jolla is Guild Chairman. Proceeds obtain opera tickets for UCSD students for the 1977 San Diego Opera season.

THE WIDE WORLD OF TRAVEL

by Ruth M. Giffin
TRAVEL WRITER



MEXICO:

- ENSENADA
- CABO SAN LUCAS
- MAZATLAN
- PUERTO VALLARTA
- ACAPULCO

Enjoy the Mexican Riviera on a mini-budget. Four to 12-day cruises aboard the newly-refurbished S.S. UNIVERSE CAMPUS.

CRUISE CASUALLY, LIVE LEISURELY ABOARD YOUR FLOATING HOTEL

The all-one-class, 625-passenger UNIVERSE is thoroughly modern, fully stabilized, all air-conditioned, and each stateroom has private bath/shower facilities. You'll find every amenity, every activity you'd expect on a \$100 per day luxury liner — swimming pool, 200-seat theater, deck sports, ship's orchestra, dancing, and acres of sun-space and fun-space on deck and in the ship's numerous public rooms. You'll enjoy the informality of our buffet-style breakfasts and lunches; and though there'll be formal table service at dinner, you'll have the option of dressing as casually as you wish. The idea is to eliminate some of the unnecessary frills to bring a Mexican holiday within the range of almost everyone. Where can you stay in a hotel with 5 meals a day for as little as \$42 per day? And with the blue Pacific and exciting ports-of-call thrown in as well!

Here's the best of Mexico — your choice of the most popular and exciting resorts fronting the blue Pacific along the famed Mexican Riviera. You can select a 4-day, 5-day, 9-day, or 12-day vacation-at-sea; and you can pick one which calls at one, two, three or four of the ports.

ACAPULCO!

When you sail into Acapulco Harbor and see the three magnificent beaches — Playa Caleta, La Condesa and Playa Hornos — you may not want to go any farther. But you must; Acapulco is much more than the romantic playground of "the beautiful people" — it's a thriving, multi-racial mini-metrop-

olis that has overtones of Rio de Janeiro and Port-of-Spain. You'll find Acapulco an un-typical Mexican city, ethnically, architecturally, and in almost every other dimension. Take a calandria (horse-drawn carriage) instead of a taxi; drink a "coco preparado" instead of a cocktail; shop till 8:00 p.m. and then sample Acapulco's fabled night life.

PUERTO VALLARTA!

Not too long ago, Puerto Vallarta was known to most people as a small, romantic, out-of-the-way seaport in an unusually beautiful setting. Except that it's no longer out-of-the-way, the description is still correct. When you watch the sun set over the Bay of Banderas, after a day of wandering through the pleasant cobbled streets or sunning and swimming on the Playa del Sol, you may decide to come back and spend a month. To remind you, take back home an embroidered shirt or skirt, rent a boat or skin-diving gear, taste the best margarita you've ever had.

MAZATLAN!

The three most important activities in Mazatlan are catching fish, eating them, and talking about them. And even if you've never had the slightest interest in fishing, you'll benefit from Mazatlan's major industry. For example, there's no more pleasant way to spend the dinner hour than in the open-air central court of a restaurant; and even without the Mariachi band, you'd agree that no bigger or better shrimp dinners are served anywhere else in the world. If you like fishing, rent a boat for an hour or a day; if you don't, try the water-skiing or the water kite, or visit the new Arts and Crafts Center on the north beach.

CABO SAN LUCAS!

Here, at the southern-most point of Baja California, the currents of the Pacific and the Gulf meet in a setting of unusual natural beauty. A great natural sea arch, visible for miles, marks the bottom of Baja — you may want to rent a small boat for a close-up view which will make one of the more spectacular shots for your photo album. On the beach you will see some massive water-sculptured rocks which will remind you of Bufano's smoothly rounded monoliths; in contrast you will

see two jagged pinnacles — Los Frailes — rising 291 feet above the water. Just below, there is an extensive drop-off into a submarine canyon where iridescent tropical fish cavort against a background of exotic coral formations. The village itself blends the Spanish-style architecture of old mission days with the new, modern resort areas of Finisterra and Baja Colorado.

ENSENADA!

Because it's close to the border, you may wonder whether Ensenada is really Mexico. It is indeed. This charming, small city on the horseshoe-shaped bay of Todos Santos (All Saints) is thoroughly foreign, totally friendly, and totalidad Mexicano. So bring your Mexican phrase-book, change some dollars into pesos, and be ready for the sights and sounds, the shops, and the excitement of Mexico.



Horsing aboard the Universe is one of many activities conducted by ship's cruise staff. Ship's newspaper, put out daily, describes the recreational program scheduled for each day, including movies, parties, tournaments, port of call talks, dance lessons, white elephant sales, et cetera.



Universe passenger displays Puerto Vallarta purchase in her stateroom. On right is distinctive Chinese blanket design. Room stewards are all adept in blanket design, with virtually a different configuration each day.

SAILING SCHEDULE

4-DAY PARTY CRUISES

Ensenada and Guadalupe Islands
July 2
Oct 22
Nov 19
Fares start at \$160

5-DAY PARTY CRUISES

Ensenada and Guadalupe Islands
May 28
Sept 3
Nov 25
Fares start at \$215

9-DAY CRUISES

Puerto Vallarta and Mazatlan with an offshore stop at Cabo San Lucas
June 2
July 6
July 15
July 24
Aug 14
Sept 10
Oct 1
Nov 30
Dec 9
Fares start at \$420

12-DAY CRUISES

Acapulco, Puerto Vallarta and Mazatlan with an offshore visit to Cabo San Lucas
May 5
May 17
June 11
Aug 2
Aug 23
Sept 19
Oct 10
Oct 26
Fares start at \$530

13-DAY CRUISE

Acapulco, Puerto Vallarta and Mazatlan with an offshore visit to Cabo San Lucas
Nov 7 only
The longest cruise of the year!
Fares start at \$580

For all of your travel arrangements see Redmond Travel in the Village, Rancho Santa Fe. 756-2438

or Orient Overseas Line, 9060 Wilshire Boulevard, Beverly Hills, California 92011



S.S. Universe Campus of Orient Overseas Line sails on year-round cruises to the Mexican Riviera from Los Angeles. Handsome 625-passenger cruise liner features budget rates which are as low as \$40 a day. Ports of call range from Acapulco to Ensenada. Length of cruises vary from four-day Party Cruises to 12-day sailings.



Enjoying Cabo San Lucas coastline, off the southernmost tip of Baja California, passengers aboard the Universe gather on Promenade Deck. All-first-class ship also features many other observation points on other public decks.

**FOREMOST WESTERN
PAINTERS AND
SCULPTORS
EXHIBITING
AT THE FAMOUS
THACKERAY
GALLERY**

PAINTERS

Bill Bender
Bill Browning
Miguel Dominguez
Gene Drew
Bart Forbes
Bill Freeman
William E. Hans
Jack Jordon
Ted Long
Roy Madsen
David Maloney
Matola Gerry Metz
David Humphreys Miller
Burt Proctor
Roy Purcell Wes Speir
Douglas Weaver
Olaf Wieghorst
and others

SCULPTORS

Ralph Crawford
Joe De Young
Alice Hooker Fay
Bill Freeman Galla
Pamela Harr
Earl Heikka
Humphriss Wayne Hunt
John Kittelson
Juan Martinez
Richard A. Myer
Harvey L. Rattey
Frederick Remington
Hank Richting
Patricia Scarano
Bob Schriver
and others

5th Annual & Bicentennial
Western & Wild Life
ART EXHIBIT
May 8th-June 30th



321 ROBINSON AVE.
AT 3RD AVE.
SAN DIEGO, CALIF. 92103
(714) 298-0171

WORLD OF TRAVEL



PLANNING A TRIP TO EUROPE THIS SUMMER? WHY NOT TAKE THE KIDS?

More and more Americans each year are including their children in their holiday plans, with the result that airlines, national tourist offices and enterprising travel agencies are collaborating on a number of vacation packages especially designed to make family travel abroad not only easy and economical but an exciting adventure as well.

Scandinavia is a particularly popular destination for touring U.S. families. For as little as \$12.00 per adult per day (children half price) you can spend a week or two on a farm in Sweden, Norway or Denmark, with full board and a wide range of activities included. Or, if you'd rather go it alone, how about a cabin in the mountains or

at the seashore? Fully equipped, this will set you back somewhere between \$40 and \$70 a week for 4 to 6 occupants, with free fishing, hiking and/or swimming thrown in. Then there's a bicycle tour of Denmark for as little as \$95 for four nights and five days including bicycle rental, meals, ferry crossings and overnight accommodation, with a special rate for children under 12.

And that's just the beginning. There are canoe trips down Scandinavia's picturesque rivers, youth hostels where a room is only \$2 a night, horseback vacations and a host of other holiday suggestions. Families seeking more detailed information should contact Scandinavian Airlines or Redmond Travel, Rancho Santa Fe 756-2438.

Start your Scandinavian holiday with the Scandinavians. Fly SAS from the West Coast, East Coast, Middle West and Canada. SAS comfort and service create a positive atmosphere from the moment you depart for a successful holiday in Colorful Scandinavia.

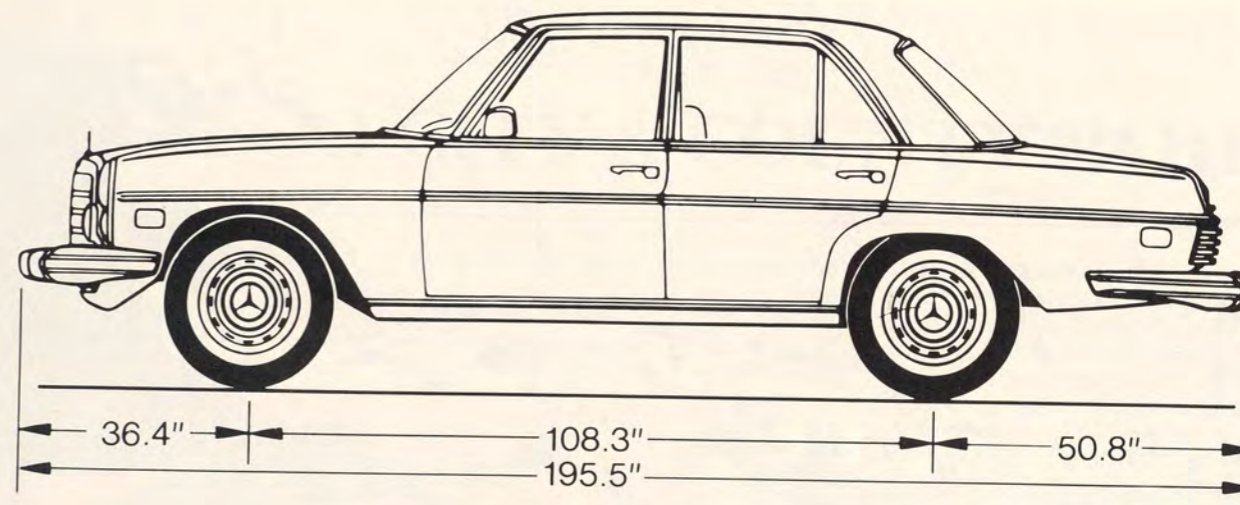

Come and test drive the Mercedes-Benz 280. See for yourself why it's the most copied sedan in the world.

Our competitors seem to like the Mercedes-Benz 280 almost as much as we do. They have models which try to look like it. They even say they have cars which drive like it. Yet no domestic sedan combines the fundamental engineering features of the 280.

Frankly, we question their claims. But you can decide for yourself. Test drive the Mercedes-Benz 280. Then compare it to any other sedan. See why it's the most copied sedan in the world.

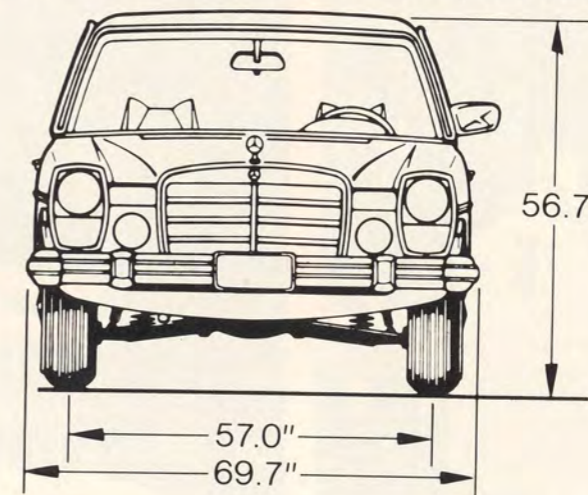

MERCEDES BENZ OF SAN DIEGO

7860 Balboa Avenue San Diego, California 279-7202
Balboa off-ramp, 15 minutes south of Rancho Bernardo on Highway 163

LOCAL GET-AWAY GUIDE: SAN DIEGO CITY & COUNTY PARKS



Solana Beach County Park, Solana Beach, offers a public swimming area, surfing area and excellent facilities



Here at the Cabrillo National Monument the discovery of the California coast by Juan Rodriguez Cabrillo in 1542 is commemorated. The "Old Lighthouse" has a magnificent marine panorama of the 14-mile bay - considered one of the most beautiful harbor views in the world

38 / MAY 1976



Quail County Park in Encinitas is a plant-lover's paradise. Its lush botanical gardens are situated amidst Buena Vista Bird Sanctuary, a 200-acre, fresh-water lagoon. Perfect for a picnic

Swimming, fishing, picnicking and camping go hand in hand with the fine summer months. Along the southern California coastline we find a variety of county, city and state parks and beaches ready and waiting to offer aquatic fun. Venturing away from the ocean water we come across an array of fun-filled inland parks, campgrounds and outdoor recreational areas.

The forty mile coastline from San Diego to Oceanside is scattered with many good swimming beaches, surfing beaches and diving areas. Various bays offer boating and water skiing activities. Most are located off of US Highway 101.

CORONADO TO LA JOLLA

Silverstrand, four miles south of Coronado, is the southernmost of the California State Parks and one of the most popular day-use parks around. So named for the millions of pieces of silvery seashell, Silverstrand is a five mile strip of land between Coronado and the mainland, boasting Pacific Ocean and San Diego Bay swimming areas. Railroad tracks and a highway run the length of the strand, but pedestrian underpasses connect the two sides. The ocean is a highly favored spot for surf fishing for perch, croaker, sea bass and corbina as well as for clam digging. Here also, people flock to watch the monthly grunion runs.

On the bayside, boating and water-skiing take over. Picnic units, restrooms, showers and concession stands are scattered on both sides. Parking area is available for over 2,000 vehicles.

Heading up the coast we come to **Mission Bay Park**, a recreational paradise, often termed a large aquatic playground. The park's 4600 acres are filled with various resorts, facilities for just about every outdoor activity, rental areas and camping grounds.

Summer programs offer instruction in cycling, swimming, boating and waterskiing among other things. Sporting equipment is available through rental services.

Various resorts — **Islandia**, **Vacation Village**, **Bahia**, **Catamaran**, **Campland** and the **Hilton Inn** to name a few — line the bayside. Each offers its own style of water area: bay, ocean and/or pool and tennis and golf facilities.

Campland is just the place to go for those who want to rough it for a while,

but still enjoy the conveniences of the aquatic park. Bring your own camping gear or rent any part of it from tents to trailers. When you tire of the camping take a step into **Campland's** pool, sauna or whirlpool. Or perhaps you would prefer to spend a little time fishing, golfing, or playing tennis. In the summer months campsites go for \$7.50-\$8.50 a night.

World-famous **Sea World**, a part of the **Mission Bay Park**, rounds off the list of fine entertainment possibilities.

The **Mission Bay** and **Pacific Beach** areas are good, casual spots for swimming and surfing. Along these beaches volleyball nets are standard structures.

LA JOLLA

The **La Jolla** beaches, just up the coast, are a bit less tame in comparison and lure the more adventuresome ocean-goers: the snorklers, surfers and divers. Coves and caves are characteristic of the area. Fascinating tide pools, with their menagerie of unusual sea life, offer hours of fun for the curious beach goer.

La Jolla beaches, curving out into the water, give an excellent view up the coast.

Wind /n Sea, off of Neptune Plaza; **Bird Rock**, popular for diving, located off of Dolphin Plaza, and **La Jolla Shores** are the three main swimming and surfing beaches in this region. A nice grassy area with a few picnic setups runs parallel to the sand and ocean of **La Jolla Shores** and a swing set provides entertainment for the younger surf-goers. Dressing facilities and restrooms are available.

Some of North County's best diving spots are located along the **La Jolla** coastline. Three places in particular house the lobster, abalone and bigger fish for which the divers search:

La Jolla Canyon, beginning 200 yards from shore, reaches depths from thirty to one thousand feet. It is located south of **Scripps Pier** and is accessible from **La Jolla Shores** on **Calle Frescota**.

La Jolla Cove, off of **Coast Boulevard**, is the place to go for snorkeling and the safest diving. No board surfing is allowed in this area.

Just south of the **Cove**, also off of **Coast Boulevard**, is the **Children's Pool**.

Scripps Canyon, north of **Scripps Pier**, is for experts only. The canyon, thirty to one thousand feet deep, is reached by boat.

Black's Beach, one of the country's few swimsuit-optional beaches, lies north of **La Jolla Shores** beach and is in walking distance along the sand. Making use of the great height of the surrounding cliffs, imaginative hang gliders fill the skies over **Black's** when the wind isn't too strong.

TORREY PINES PARK TO OCEANSIDE

Continuing north, off of **Route 101**, we come to the outstanding **Torrey Pines State Park** which offers three main areas of interest. A reserve fronts the ocean with 20-million-year-old, red-brown cliffs. A beach area provides a nice place for swimming and surfing, and an estuary is home for many forms of wildlife.

In the reserve we find over 200 different native plants, several of which are found exclusively on the reserve. The **Torrey pines**, for which the park is named, number over 2,500. Growing in mystically twisted and contorted figures, these trees expose the dry and unprotected surroundings in which they grow. Some of the pines age over two hundred years.

Half of the thrill of the reserve comes from walking on any of the trails winding down, around and through the cliffs. These trails may take the wanderer down to the ocean or to lookout points hundreds of feet above.

Camping, smoking or fires are prohibited in the reserve but picnic tables are scattered near park headquarters. A \$1 parking fee is requested.

A short, winding, downhill drive through the cliffs lands us at the 4½ mile stretch of beach of **Torrey Pines**. The swimmer is cautioned against occasional tide pools when lifeguards are not around. Surf fishing for croakers, perch and corbina is popular here.

The estuary, abounding with various waterfowl, smaller fish and mollusks, lies behind the beach. Here one may swim in quiet deep water at high tide or wade through the shallow pools during the lower tides. A good place for small skiffs and paddle boats.

Sea Grove City Park marks the next park in our northward route, located in **Del Mar** off of **Coast Boulevard** and **17th Street**. Volleyball nets and fire rings make this a good spot for barbecuing as well as swimming, surfing and diving.

Bordering **Del Mar** and **Solana Beach** is **Bluffs Preserve City Park**.

CITY & COUNTY PARKS

Here we are just as apt to see Del Mar Race Track horses being exercised along the beaches as surfers or swimmers. Parking facilities are limited.

From Solana Beach to Oceanside good swimming and surfing waves are created by offshore reefs. Along this coastal area we find quite a line of State and County parks and beaches.

Solana Beach County Park, off of Plaza Street, offers a public swimming area with facilities.

Tide Beach County Park, also in Solana Beach, located at Cliff Street and Pacific Avenue has swimming, surfing and diving areas. Picnic facilities are also available.

Sea Cliff Park, a roadside park, lies above the ocean in Encinitas with access to the water and facilities.

Cardiff State Beach, off of Chesterfield Drive, offers picnic facilities and good swimming, surfing and diving areas.

Glen County Park in Cardiff has picnic and recreational set ups.

Just north of here we find **San Elijo State Beach**, one of the few which offers overnight camping. San Elijo is located on the bluffs near the mouth of a lagoon off of Montgomery Avenue in Cardiff. Stairs descend to the beach

and a more gentle surf than that of nearby beaches.

San Elijo has over 170 developed family campsites complete with table, stove and cupboards. A water supply, restrooms and hot showers and laundry facilities are close at hand. Concession stands supply everything from groceries and snacks to bait and equipment rentals of such things as surfboards and beach mats. The campsites accommodate campers or trailers up to 28 feet. Summer stays are limited to seven days. Though dogs are not permitted on the beaches they may join you while you camp out. Campsites are available through Ticketron.

Continuing north we come to **Ponto State Beach**, also called Leucadia State Beach, situated in Leucadia on Neptune Avenue. Parking space is available between Fulvia and Jasper. Swimmers, surfers and divers fill the beach while picnic goers utilize the picnic facilities located near the Fulvia parking area in the Leucadia Roadside County Park.

Moonlight Bay, west of Encinitas on B Street, is one of the more narrow beaches backed by high cliffs. A barbecue and picnic area with fire rings are available for summertime gather-

ings. Concession stands and a playground are also found here.

Seaside Gardens and Encinitas Beach County Park are both off of Neptune Avenue in Encinitas. The area is open to swimming and picnicking.

Four miles south of Carlsbad, the flagpole on Route 101 marks the entrance to **South Carlsbad State Park**, open for overnight camping. A little bigger than San Elijo State Park, South Carlsbad offers 226 family camping areas, concessions, laundry and similar facilities on forty-five acres of beach and bluffs.

Carlsbad State Beach off of Carlsbad Boulevard is best known for its surfing. Yearly surfing contests are held at this site. Dressing facilities and restrooms are available.

Near Carlsbad State Beach is the **Buena Vista Bird Sanctuary**, a 200-acre, fresh-water lagoon. **Quail County Park**, located in this sanctuary makes a peaceful picnic area. Botanical gardens in the park are open for viewing 8-5 daily.

Oceanside, the northernmost of the North County beach areas, is a good spot for body surfing, but be careful of the rip tide currents near the pier.

INLAND PARKS

Leaving the oceans and heading inland we find several beautifully

wooded and lakeside parks, both private and public including several set up with camping facilities.

Balboa Park, accessible by Highway 5 and 163, is probably the most outstanding and extensive park in the area. Beautifully landscaped walking and bicycle paths lead through a maze of entertainment ranging from the world-famous **San Diego Zoo**, housing animals in their natural environments, to a crafts center and the **Old Globe Theater**. Two art galleries, three museums, two dozen tennis courts and a golf course are available for public enjoyment as well. Scattered benches and picnic tables are open invitations to sunny day picnics.

Jumping inland, east of Escondido, is the exotic **San Diego Wild Animal Park**, an 1800-acre wildlife preserve originally set up to preserve and conserve endangered species.

Nairobi Village, an authentic African village at the park's entrance sets the mood for your unique safari. Here you encounter the world's largest walk-through aviary, a giant gorilla grotto, an animal care center, exhibits and places to eat or buy gifts.

From the village you may climb aboard the **Wagasa Bushline**, a quiet electric and non-polluting monorail which will take you on a five-mile journey through the animal herds and

bird flocks in their natural environments.

The more energetic park visitor is invited to hike around the 1/4 mile **Kilimanjara Hiking Trail**. Spotted along the trail are many comfortable picnic spots as well as wonderful lookout points over the one-hundred-twenty acre East African section of the park.

The ever-expanding summer entertainment program is more than inviting! From now until May 31 birds, elephants and horses are being trained for the summer shows. Bird training is open to public viewing daily at 11 a.m. and 2:15 p.m. and elephant training may be seen at noon and 3:15 p.m.

June 1 marks the opening date of the summer shows to be held in the park's three amphitheatres.

Beginning July 1 and continuing through September 6 new visiting regulations will take affect. The park will continue to be open from 9 until 9 but any visitor already in the park at 9 p.m. will be allowed to stay until 11. The last monorail will have a 10 p.m. departure time.

Two more new features of the summer program will be an African buffet dinner at the **Mombasa Cooker** located in the village and a night safari tour. This tour, the first of its kind, will enable the visitor to experience the

sounds, smells and sights encompassing the animals' night lives.

Various smaller parks filter the North County landscape making perfect spots for picnics and other outside enjoyment.

Beginning with the more southern parks we come across the **Lower Otay Recreational Area** off of Telegraph Canyon Road in Chula Vista. A fourteen day camping limit is placed on this rural park which offers a boat launch and boat rentals and a playground. A fishing area lies within one mile of the park's reach.

Moving north and five miles east of El Cajon, we find **Lake Jennings County Park** where access to a lake makes fishing and boating everyday events. One hundred acres are open to camping. A 14-day limit is placed on camping stays and trailers are limited to 25 feet. Pets are welcome to join the camping fun. Full facilities are available.

San Diego County Park on Sun Valley Road, Lomas Santa Fe, offers a quiet picnic area. A concrete slide and footbridges are available for child play.

Just south of Escondido we find **Felicita County Park**, a small area with facilities.

Traveling thirty-five miles from Escondido via Highway to the Stars brings us to **Palomar Mountain**

For the best game you ever played... and the best time you ever had!

Vic Braden. Jack Kramer says he's the world's best tennis coach. His students say he's the funniest. He says he can make anybody a better player... from dinkers to advanced players. The Vic Braden Tennis College. At Coto de Caza, a 5000-acre country resort. With air-conditioned classrooms for films and Vic's famous strategy sessions. 17 geometric training alleys with automatic ball machines... 900 balls an hour! Lighted courts. Four video analysis centers.



Fully stocked pro shop... even free Band-aids. Expert staff. Personal attention. Beautiful guest lodge, dining, riding, family recreation of all sorts. Have a great time playing better tennis. Two-day weekend courses. Three and five-day clinics starting each Monday. Call today for information, reservations and directions: (714) 581-2990. Or mail this coupon:



To: The Vic Braden Tennis College
22000 Plano Trabuco Canyon Rd.
Trabuco Canyon, CA 92678

My game needs help. I need a few laughs.
Please rush Tennis College information to:

Name _____
Address _____
City/State _____
Zip _____ Phone _____

The Vic Braden Tennis College
at Coto de Caza, California



ROSS THIELE & SON is the longest established name in interior design in San Diego County. They also carry a wide selection of antique and contemporary furnishings for the home and office. Its SALA VERDE shop offers fine gifts and accessories.

These four award-winning professionals are available to help you with commercial or residential interior design: M. Terry Anderson, FASID; John W. Thiele, ASID; Richard H. Whitney, ASID, SIDA; Richard S. Young, ASID.

Ross Thiele & Son, La Jolla

the bishop's schools la jolla, calif

adult clinic

June 6-12
One Week
In cooperation with the La Jolla Beach and Tennis Club. Both resident and day welcome.

the bishop's schools la jolla, calif

tennis camp

FOR BOYS & GIRLS, 12-18
10 one-week sessions beginning Sunday, June 13, 1976 and ending Saturday, August 21, 1976.

For Information Write:
Joseph H. Wesson, III — Director
The Bishop's Schools Tennis Camp
Room A-7607 La Jolla Boulevard
Box 1948
La Jolla, California 92038
Telephone (714) 459-4021



1932 Chevrolet

Where the Shoppers
Buy their Cars
Old and New!

QUALITY CHEVROLET COMPANY

745-7221
Broadway and Valley Parkway,
Escondido, California

CITY & COUNTY PARKS



Infinite in variety and almost unsurpassable in beauty, San Diego's Balboa Park covers 1400 acres within the heart of the city. The park is the site of many San Diego



San Dieguito County Park on Sun Valley Road, Lomas Santa Fe, offers a quiet picnic area. A concrete slide and footbridges are available for child play.

County Park. A 15-day limit is placed on camping stays in this heavily wooded area. Facilities are available. Two more quiet little North County parks include Wildwood City Park on Vista Way and Live Oak County Park on S15 near Fallbrook. One of the larger camping sights, with 182 camping units is Cuyamaca Rancho State Park, located fifty miles east of San Diego on N US 80. Trailers are permitted, but camping is limited to 15 days between June 1 and September 15. The camper's stay here may be highlighted by hiking, a naturalist program and fishing. A laundry area and showers are available. Cleveland National Forest, site of the Palomar Observatory, is the place for longer overnight camping expeditions. Located between desert and ocean, this national forest has an unusually mild climate. The area was set up mainly as a watershed forest, but offers a rather extensive number of campsites, areas for hiking, riding and boating as well as for fishing. Summer recreational programs are also run here.

Here's a run-down on some of the

Forest's campsites closest to North County:

Descanso — 3550', 2 mi. north of Descanso junction, 44 mi. east of San Diego. Four camping units, trailers permitted.

Guatay — 3900', 1 mi. west of Guatay, 45 mi. east San Diego on US 80. Five units, no trailers, no water.

Pine Creek — 3700', 48 mi. east San Diego at Pine Valley just north of US 80. Three units, no trailers.

Glenclyff — 3600', 50 mi. east San Diego, 1 mi. east Laguna Junction on US 80. Six units, trailers, no water.

Boulder Oaks — 3000', 55 mi. east San Diego on US 80 at Boulder Oaks. Six units, trailers, supplies.

Burnt Rancheria — 6000', 60 mi. east of San Diego via US 80, 11 mi. west of Laguna Junction. 100 units, trailers, open Feb.-Nov.

Laguna — 5600', 63 mi. east San Diego via US 80. 14 mi. west of Laguna. 100 units, trailers, open Feb.-Nov.

Horse Heaven — 62 mi. east of San Diego on US 80. Group camps in Laguna recreation area. Reservations needed from the District Ranger. Three

units for 15-50 people, stoves, water, facilities. Stay limited to two days to one week.

Palomar Mountain, sight of the world's largest telescope — 5300', 26 mi. east of Escondido, the mountain has 51 units and areas for hiking and horses. Laundry and showers are also available. A small fee is requested. Thirty day camping limit.

Crestline, on Palomar Mountain, 11 mi. west of Lake Henshaw, and 5.3 mi. east of Rincon Junction has eight units. No trailers are permitted. Open Feb.-Nov.

Four more campsites in Cleveland National Forest located relatively close to North County are the following:

San Luis Rey — 2550', 2½ mi. west of Lake Henshaw on the State Highway. 30 units, no trailers. Fishing all year on Lake Henshaw.

Oak Grove — 2750', 25 mi. southeast of Temecula, 15 mi. northwest of Warner Hot Springs on State Highway 79. 20 units, trailers permitted.

Indian Flat — 3600', 10.2 mi. north of State 79 via forest dirt roads. Ten units, trailers, deer hunting.

Black Canyon — 2000', 11 mi. west of Ramona on Roman-Mesa Grand Rd. 14 units, trailers.

Private campgrounds and recreational areas, though numerous in North County, are clumped in the Escondido environ. Here we focus on six sites in particular:

The **Artesian Lake** resort, nine miles north of Escondido on US 395, offers water fun, a boat launch and room for tents and trailers. A snack bar/cafe is found on the premises as are full facilities. Reservations are accepted.

North Escondido KOA on US 395 is 11 miles north of Highway 78. Here one may swim in the pool, fish and make use of the recreational hall. A store and laundry are located on the premises. Within five miles of the KOA a golf course is open for public use. A thirty-foot limit is placed on trailers.

Ivy Del Trailer Park lies in a rural area four miles north of Escondido. Space is available for over 40 trailers. A swimming pool, recreational hall and playground as well as a public golf course, within five miles of the area, are opportunities for a fun stay. Laundry facilities are also available. Adults only.

Tent and trailer space is provided by **Lake Wahlford Resort** located six miles northeast of Escondido. In a mountainous and heavily wooded area we may spoil ourselves with fun while making use of the boating, fishing and horseback riding areas. A boat dock and launch are also available. A snack bar and store are open to the visitor. Tables and firewood are also available.

Woods Valley Kampground on Woods Valley Road 9 miles north of Escondido

continued on page 45

Everything in Moderation.

Except Bette and Barney & Barney.

The team of Cunningham Insurance - Barney & Barney doesn't believe in moderation.

Not for a minute.
Not when it comes to working hard for Rancho Santa Fe. Or all of North San Diego County, for that matter.

Not when it comes to being involved in the needs of the community.

Bette Cunningham, backed by Barney & Barney, is on-the-spot, as she has been for years. With a complete range of financial and insurance services. With a business that's growing larger by the day.

There's no moderation in Rancho Santa Fe. At least not for Bette and Barney & Barney.

BARNEY AND BARNEY Since 1909

CUNNINGHAM AGENCY

Casualty Insurance — Property Insurance — Surety
Bonding — Pension and Profit Sharing Plans —
Life, Accident and Health Insurance Plans — Estate
Planning — Complete Claim Service

Cunningham Insurance - Barney & Barney, Paseo Delicias, Rancho Santa Fe, Calif. 92067—Ph. 756-2117



The Clifford Farrar Pet Rock

Clifford Farrar

JEWELERS

7802 Girard Ave. (Sanderson's) La Jolla 459-2407
Rancho La Costa 753-8242
Maui Hawaii 661-4594 661-4552

INVESTMENT STRATEGY

by E. Donald Frick

PORTFOLIO CONSTRUCTION

Building a portfolio of stocks and bonds, custom tailored to the individual's very personal criteria, is an exciting and important project. It should be a joint undertaking by the investor and his stock broker, investment adviser or both.

For his part, the professional contributes knowledge of the myriad of strategies and products available in today's financial world. The client, in turn, must be completely honest and forthright in presenting all the material and human facts pertinent to intelligent decision-making.

The scope of necessary client information ranges far beyond reciting "name, rank and serial number." It includes need, assets, income, future resources and potential liabilities, family facts and philosophy, estate planning, pride, prejudices, habits and inhibitions.

Has the client had a happy history of

common stock investing? Or a frustrated one? Has he gambled too much? Too little? Has inflation sabotaged his buying power? Does he have enough income or is he depriving himself because of a deficient cash flow? Does his wife have any interest in, or knowledge of, investment strategy? Does he want to create inherited wealth for his children? Or for charity? Will he face potential extraordinary future expenses — college educations, care of aged parents, capital needs in his own business?

Years ago, it was common practice for the practitioner to lump all his clients into three or four categories, depending on age, assets and income requirements. He then had a "pat" program which he superimposed on the particular slot into which the client fit.

In the 1940's, a certain bank trust department bought four core stocks for most common stock accounts — American Telephone, General Motors, U.S. Steel and United Fruit.

Big New York City banks used the glamour growth stocks — Avon, IBM, Polaroid and Xerox — during the next two decades. It would seem that in each case the stocks were designated to be held forever. Further monitoring and supervision may have been deemed unnecessary because these stocks either had "guaranteed" growth ahead of them, or were so basic to the economy as to be untouchable.

History provided both of these "sacred stock" theories to be invalid. U.S. Steel, General Motors and American Telephone reached their all-time highs 15-20 years ago. United Fruit, now United Brands, has sailed on troubled waters in recent years. In only one of the four did dividends increase sufficiently to help offset inflation.

The collapse of the Super-Glammers in 1974 was well advertised.

Because constant change is now our ordinary way of life, the investment portfolio (however well it was initially crafted) must be constantly monitored and adjusted. New laws, new fashions, politics, war, inflation, pyramiding debt, interest rates — kaleidoscopic changes have called for periodic fresh approaches.

As one small example, let's look at the cross-currents which have buffeted an investor who bought *safe*

government and corporate bonds and Treasury bills in the last 20 years:

- In 1958, U.S. Treasury bills (90-day) yielded 1%

- In 1969, and again in 1974, T-bill rates soared to 9%. Today the yield is "only" 5%.

- In 1955, long-term AA rated corporate bonds paid 4¼%. In 1969, and again in 1974, rates rose near 10%. Today the yield is 8¾%.

The astute income investor would have owned Treasury bills during 1973 and 1974 as rates were rising; he'd have shifted into intermediate (5-8 year maturity) corporate and government issues in early 1975 at 8-10% yields, as T-bill rates began to fall; today he'd be considering whether to extend into longer maturities.

Common stock investing has been a hazardous undertaking in recent years. The bear markets of 1970 and 1974 have scarred many heretofore successful investors.

A minority of stockholders foresaw trouble in 1972-73. Interest rates were climbing, inflation was at record levels, the Dow Jones stocks sold at almost 20 times earnings (and even those earnings were inflated by inventory accounting) and dividend returns were at their lowest levels in many years. Pru-

dence called for a cutback in equity holdings with a percentage of assets temporarily set aside in cash-equivalent reserves.

In late 1974, reverse patterns began to appear. Dividend yields rose to their highest level since the 1950's, interest rates began to descend, and the Dow Jones average could be bought at less than 10 times earnings. Speculative stocks had declined as much as 90%, and even "blue chip" giants were down 30-60%. It was a time to buy stocks if one had faith in the country's ability to survive and prosper.

Did many people react this way? Did they have adequate advice? Are they preparing for any future trends in inflation, interest rates, FRB policy?

Do they give tender, loving care to their investments? More so than ever before, they should!

E. Donald Frick is an investment executive associated with the Shearson Hayden Stone office in Rancho Santa Fe. He has been professionally employed in money management for 17 years as a corporate treasurer, investment counselor and stock broker. A native of Ft. Lee, New Jersey and graduate of Colgate University, Frick has been a resident of Rancho Santa Fe since 1964. He served as a naval officer in World War II. □

PARKS

continued from page 43

has space for many trailers and tents. A public golf course is located within five miles of the camp and snow skiing areas are open within 25 miles. Reservations are required.

Palomar Trailer Park, on South Escondido Road has very limited trailer space. Swimming, boating (rentals available) and fishing are open to the visitor. A laundry area is located on the premise and a store and snack bar may be reached within one mile of the camp.

Heading back in the westward direction we come to the lovely Lake San Marcos, sight of many beautiful private homes. An inn and lakeside cottages are open to visitors. For recreation the guest may choose to spend some time in one of the two pools, on the tennis courts or putting around on the private golf course.

Moving to Encinitas we find one other private area: **Sea Aire Mobile Park**, located on North Vulcan off of US 101 and Interstate 5. Limited area is available for trailers restricted to 22 feet in length. There is access to swimming areas and within one mile there are fishing spots. A store and snack bar are also nearby. Facilities are available. □

SAN JOSE NONSTOP EASY.

Expanded round-trip service! The only morning and evening nonstops plus frequent direct flights to San Jose Airport. Lower fares and savings for groups and families, too. So call Easy Information first. If there's an easier way to get you there, we'll be the first to tell you.

Call Easy Information in San Diego, (714) 235-7301, or your local travel agent.

F.SJO/SAN 3



Photography by Van Pelt

the game room

We believe the game room should become one's own personal retreat. Our bar system and wall areas create your private corner of the world, a place to fantasize, to meditate, to contemplate.

ROBERT ELY
Interior Designer

LARSON'S RESIDENCE
The Collector, Fallbrook

Eclectic Interior Design

At the Vineyard 1523-18 E. Valley Pkwy. Escondido Open 10-6 p.m. Monday thru Saturday. Decorating Service Available 743-4296

THE TENNIS RACKET

by Dave Martin

MATCH-UPS AND MATCHES

As the North County Doubles League wound down to its close some observations should be noted.

- At all levels the deciding factor is often the degree of skill demonstrated at the net.
- After serve, the average number of returns in doubles is somewhere between three and four. The steadier team almost always wins. An exception, of course is the match

which is really a singles match between the opposing deep players while the net partners stand and observe the exchange of ground-strokes.

- The "down the alley" serve return, while a rather low percentage shot in general, often proves to be an irresistible temptation to the inexperienced doubles player.
- The often maligned and scorned lob still remains as the most effective

doubles weapon to dislodge the opposing net man or defend against his attack.

TECHNIQUES AND TACTICS

As approach shot and volley skills improve, it is natural to begin this pattern at a point increasingly farther from the net. Often, when you start your approach from nearer the baseline, you find the return back at your feet or out of reach before you have moved inside the service line.

In this case try to vary your drive approach shot by chipping or slicing the ball softly but deep to the baseline. The change of pace will upset your opponent's timing and the softly hit ball will allow you to move in closer to the net before his return is made. Also, the slice causes a lower, skidding bounce which is more difficult to hit as a passing shot. Warning! Be alert for the lob.

RULES AND RHUBARBS

Is your serving rhythm such that the second ball is hit almost before the first serve lands fault? If so, try to be a little more deliberate in starting your toss. Rule II states that the server may not serve until the receiver is ready.

If he claims to be not ready and makes no attempt to return your service, you may not claim the point, even though the serve was good.

Make sure to establish eye contact with the receiver before each serve. Your serve will often be better because you have taken the time to be more deliberate in your action.

PROBLEM SOLVING

Soft-ball Sam plays at every club and public tennis facility. He seems to win more than his share of matches, too. More accurately, he allows his opponents many opportunities to lose as he floats his high arcing, semi-lob back to the exact intersection of the service lines. His margin for error in all directions is so safe there is small chance of error unless he is forced out of his preferred pattern.

After an exchange or two try moving in to the service line, take the soft return in the air, volley it deep to the corner and make Sam hit the next shot under a little more pressure. He now must make a better return than he wishes to try and often an error or a set-up return will be the result.

At any rate, while patience is required when you play Sam, to play his game usually dooms you to defeat, since he is probably better at it than you are.

Remember, try to make him play at a faster pace than he likes and you can often discourage the "moon-ball" tactic.



Hours 8 a.m. to 10 p.m.
Cocktails
For Reservations 756-2855
Paseo Delicias and La Granada Rancho Santa Fe



NOW... The convenience of having Funeral, Cemetery, Mausoleum and Crematory facilities all together in one beautiful setting.

EVERYTHING IN ONE PLACE

 **EL CAMINO MORTUARY**
& memorial park

9450 Carroll Canyon Road, San Diego, CA 92121/Phone 453-2121



In the olde Spanish days this sign meant Hospitality...

It still does.



Had you stopped in at Rancho Santa Fe (then known as Rancho San Dieguito) in the 1800's, you would have been met with smiles, handshakes, food and lodging for the night, a fresh horse for the morning, and even a bowl of coins in your room—in case you were short for the journey ahead. In those days, hospitality was more than a politeness, it was a revered custom, a way of life.

Stop in at Rancho Santa Fe Savings and Loan today and you'll find the same spirit

of hospitality still going strong. We may express it a little differently, but the idea is the same: we take the time to get to know you and to help you meet your financial needs.

At Rancho Santa Fe Savings and Loan we offer a wide choice of savings plans paying the highest interest rates in the nation.

We offer a host of convenient free services... money orders, travelers checks, save-by-mail service, monthly collection accounts, notary service, coffee... but most important is our personalized service by genuinely friendly people. What keeps us friendly and close-knit? We're locally owned and operated. That lets us get to know you, be responsive to your needs, and live up to your expectations of what your savings and loan should be.

Our brand stands for hospitality. It also stands for security. Rancho Santa Fe Savings and Loan is a sophisticated

financial operation, federally insured and well-managed by experienced financial professionals.

At Rancho Santa Fe Savings and Loan you're more than an account number...

you're an honored guest. Please stop by any time. We're always ready with a smile, a handshake, and friendly help for those journeys ahead.



Rancho Santa Fe Savings & Loan Association
A Heritage of Hospitality • Your Brand of Savings and Loan.

MAIN OFFICE
Via de Santa Fe & La Flecha,
Rancho Santa Fe, California 92067 (714) 756-3777

LOMAS SANTA FE
677 Lomas Santa Fe Drive,
Solana Beach, California 92075 (714) 755-9791

LA JOLLA
7770 Girard Avenue
La Jolla, California 92037 (714) 454-6133

Open Saturdays 10 to 1



REAL ESTATE RAP-UP

SECOND PHASE UNDERWAY AT SANTA HELENA

Although still under construction, half of the units in the first phase of 36 golf course condominiums at Lomas Santa Fe's Santa Helena Park have been sold, and construction of 28 units in the second and final phase has been started.

First move-ins in Phase I are expected about mid-June.

Three floor plans are offered:

- Single-story with two bedrooms plus den and two baths;
- Two-story with two bedrooms and 2½ baths;
- Two-story with two bedrooms plus study or optional third bedroom and 2½ baths.

All have attached two-car garages with electronic door openers.

The living areas range from 1,250 to 1,536 square feet, and the units are priced from \$57,900 to \$70,900.



Overlooking the fairways of the Lomas Santa Fe Country Club championship golf course are these two and three bedroom condominium residences under construction at Santa Helena Park. First move-ins are expected about mid-June.

Features include fireplaces; wetbars; vaulted, beamed ceilings; ceramic tile entries; ceramic tile in showers and baths; sliding glass doors to patios; decks, or balconies, and tile roofs.

Kitchens have hardwood cabinets, ceramic tile countertops, pantries, luminous ceilings and built-in electric appliances including dishwasher, disposer and combination range and double-oven with self-cleaning lower unit.

All exterior walls are fully insulated, and there is double-wall construction with an air space and soundproofing between adjacent units.

Recreational facilities for residents and their guests include a clubhouse, pool and spa. A cart path connects Santa Helena Park with the private Lomas Santa Fe Country Club.

48 / MAY 1976

COLDWELL BANKER REPORTS RECORD SALES

Coldwell Banker Residential Brokerage Company's La Jolla office completed 1975 with a record-setting \$22,052,000 in home sales handled by its 22-member sales staff. According to Robert R. Jackson, vice president and resident manager, the La Jolla office sales staff participated in 247 home sale transactions. This compared with 199 residential sales valued at \$17,392,000 recorded in 1974.

Eila Haubrich was the office's top dollar producing sales associate for 1975, handling 22 home sales valued at \$2.9 million. Other office top producers were Peggy Chodorow and Bebo Mallory, with \$2.3 million and \$2.2 million in sales, respectively.

In terms of unit sales, Chodorow was the office leader during the past 12 months. She led the office with 32 home sales, followed by Haubrich and Mallory, each with 22.

Top office honors for securing listings in 1975 went to Chodorow who obtained the right to exclusively represent owners of 29 homes in selling their properties. Roy Fuller was runner up with 27½ listings and Schneider was third with 18.

Jackson commented that the increasing popularity of the La Jolla area, coupled with his firm's relocation services staff played a significant role in the record-setting year of home sales. Continued lowering of the mortgage loan interest rates, readily available home mortgage monies and a pent-up demand for family housing is expected to be reflected in a continued high level of home sales activities in early 1976, he added.

Coldwell Banker Residential Brokerage Company's La Jolla office is one of nine locations throughout Southern California dealing primarily with the resale of fine homes. Other offices are situated in Laguna Beach, Newport Beach, Palos Verdes, Brentwood, Beverly Hills, Hancock Park, Encino and San Marino.

Brokerage fees from home sales last year accounted for more than a quarter of parent company Coldwell Banker's gross revenues of \$76.5 million.

Coldwell Banker Residential Brokerage Company is one of the companies of Coldwell Banker (NYSE/PSE), a real estate and real estate-related service firm with a staff of more than 3600 operating 183 offices from 115 locations in the United States. □

CC&F NAMES REGIONAL VICE PRESIDENT

Cabot, Cabot & Forbes Co., national industrial real estate developers, have announced the appointment of Bernard W. Gilmore as vice-president and general manager of the San Diego regional office.

He will be in charge of development, leases and sales for the firm's two industrial parks in San Diego County; the 140 acre CC&F San Diego Industrial Center on Miramar Road and the 340 acre Palomar Airport Business Park in Carlsbad.

"Gilmore's background in dealing with international companies and his experience as an executive in the electronics industry will be a valuable asset in attracting high quality new industry to the area," Hewson said.

"CC&F believes that San Diego County is one of the most attractive locations in the U.S. for light industry, distribution and research companies," Hewson added.



Bernard Gilmore

The CC&F Palomar Airport Business Park is a partnership consisting of companies affiliated with Cabot, Cabot & Forbes Co., Mitsui & Co. (USA), Inc. and Mitsui Fudosan (USA), Inc.

The joint venture partnership represents the first major participation by Japanese companies in industrial park development in the United States. Mitsui & Co. Ltd. is the oldest trading company in the world, providing world-wide manufacturing representation for several hundred Japanese firms.

CC&F, based in Boston, has developed more than 47 industrial parks nationwide, through its subsidiaries, including eight in California totaling 2,500 acres.

MEADOWS HOMES OPEN IN VILLAGE PARK

The grand opening of an additional 19 single family homes in The Meadows at Village Park has been announced by James M. Saivar, marketing director for Avco Community Developers, Inc. San Diego communities.

The existing 52 single family homes in The Meadows were sold out within a year. In response to interviews with people touring the models, the 19 additional homes will be enlarged to expand the living space by over 100 sq. ft.

"We are building three of the four previous Meadows homes with the additional space at very little extra cost to the buyer," Saivar said.

According to Saivar, The Deerfield model is the most popular home in The Meadows with its circular island kitchen which looks out across the breakfast bar into a large family room. The living, dining, and family rooms have been enlarged and the plan is now 100 sq. ft. larger to 1710 sq. ft.

The Meadowbrook, a four bedroom, two bath plus powder room model, will have about 100 additional sq. ft. in the living room. It now totals 1917 sq. ft. The living room of The Parkside, a two-story, five bedroom model will be expanded by 142 sq. ft. to 2318 sq. ft. Prices range from \$52,900 to \$63,350.

The 19 units are currently under construction with expected completion in July.

Recreation facilities which include a swimming pool, tennis court, tot lot and picnic area will be available to residents of The Meadows for a monthly fee.

Village Park is a planned residential community, three miles east of Interstate 5 on Encinitas Blvd. It is a development of Avco Community Developers, Inc. (ACD).



The Deerfield model in The Meadows at Village Park features a circular island kitchen which looks out across the breakfast bar into a spacious family room. There will be three floor plans available in the additional 19 homes currently under construction.



Are you a creative writer, artist or craftsman?
If so, this contemporary ranch home is for you!

This is a delightful Ranch estate, ingeniously built on 1.49 acres, just two minutes' drive from the Village center. Two spacious levels, so there's always room for privacy, 3 bedroom, 3 baths, fireplaces — and much, much more. Lots of wood and glass. Separate guest house with open beam ceilings. Swimming pool, paddle tennis court, inside-outside family room. A splendid buy on today's market!
\$185,000

Kay Wasser & Associates

P.O. Box 136/Rancho Santa Fe, Ca. 92067/714-756-2436
Corner of Avenida de Acacia and La Flecha
Carol R. Hard Judi Woods



Innovations by Barry

Specialists in Quality Custom Made Draperies and Window Treatments

Custom Bedspreads	Shutters	Levolor Blinds
Woven Woods		Roman Shades

Complete Installation Service
We operate our own work room

1175 Industrial Avenue, Suites S & T, Escondido

747-5110

RANCHO SANTA FE PROPERTIES

MANAGING BROKER
Charles A. Chapin

ASSOCIATE BROKERS
George A. Baldry
James L. Jarnagin

ASSOCIATE
Grace Iarrobino



Across from the Inn Paseo Delicias Rancho Santa Fe



JANE BRETT Rancho Santa Fe REALTOR



756-1442

La Granada & Paseo Delicias

Among the riches of Beverly Hills is a little gem of a hotel...



Decently priced, a stroll from Gucci, Van Cleef & Arpels, Mark Cross; 100 rooms, two penthouses; 20 minutes — and a world apart — from L.A. airport. Among the pleasures of the city, our own notable Chez Voltaire restaurant and piano bar.

Max Baril's new
Beverly Rodeo Hotel

360 No. Rodeo Drive, Beverly Hills, California
(213) 273-0300 Outside of California Call Toll-Free
(800) 421-0545

REAL ESTATE RAP-UP

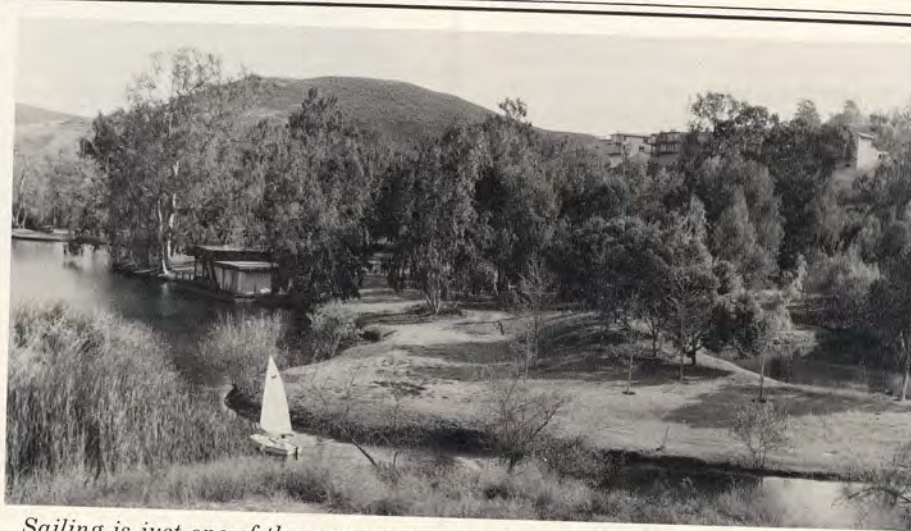

Sailing is just one of the many recreational opportunities available to Lake Val Sereno residents. The homes, which are built on the edge of a lake in Olivenhain, offer fishing, picnicking, hiking — and plain old enjoyable living.

LAKE VAL SERENO OFFERS LAKESIDE LIVING

Ever live on a lake? You can if you live at Lake Val Sereno. Lake Val Sereno is a luxury townhome development overlooking a lovely private lake secluded in the gently rolling hills of Olivenhain — one of San Diego County's nicest residential areas. Lake Val Sereno combines luxurious living with a beautiful lake-front location. "Lake Val Sereno," said Medalist Corporation President, Stan Sopczyk, "is a place that people can come home to — and feel good about. Lake Val Sereno is a very special place to live."

Lake Val Sereno's Phase II project has been the object of tremendous buyer and investor interest. The three floorplans feature two stories, two bedrooms with convertible dens, oversized two car garages and 2½ baths. The models, which have only recently been constructed, offer sunken living rooms, formal dining rooms, and raised hearth fireplaces. One model even features a dramatic Captain's Loft bedroom. The bedrooms feature custom carpeting, large walk-in closets, view windows and sliding glass doors that lead to balconies. The roomy living areas of Lake Val Sereno homes offer exposed beamed ceilings, wood burning fireplaces, wrought iron railings and planter areas.

A host of designer additions reflect Lake Val Sereno's luxurious design. Dual lock, extra heavy front doors are placed for added beauty and security. Private inner courtyards are an added touch for quiet, personal entertaining. Lake Val Sereno's interior design was

created to blend harmoniously with the magnificent beauty that surrounds every Lake Val Sereno home.

Then there's the lake itself. Lake Val Sereno is approximately one half mile long in front of the development and continues in a meandering fashion throughout the back of the development. The lake, while man-made, is in a natural run-off channel, thus guaranteeing that the lake will always be filled. Three fishing ponds have been stocked with bass, bluegill and catfish.

Lake Val Sereno is not only a great place to go fishing, it's also a nice place to go boating or take a walk. Rowboats, canoes and small sailboats can often be seen lazily drifting their way across the lake's expanse. For those who prefer things a little slower, Lake Val Sereno offers a picnic area which comes complete with a barbeque and benches situated in one of the prettiest places within the entire development.

Equestrian trails wind their way throughout the development and into the hills. Lake Val Sereno, while softly secluded, is close to beaches, golf, shopping, and is only a 30 minute drive to San Diego.

"Lake Val Sereno teems with wild-life," salesperson Beverly Palacios stated. "We have a lot of wild birds that live around here all year round. During the winter we get herons, white egrets, magnificent falcons, and even Canadian geese! At night you can hear coyotes howling. Animals of all sorts live around the lake."

THOMAS-FLETCHER-NICOL STARTS QUARTERLY SURVEY

Thomas-Fletcher-Nicol Co. is conducting quarterly surveys of the San Diego County real estate market to determine trends and future expectations in housing, interest rates, commercial and industrial sales and leasing activity.

Kip Nicol, TFN president, said the survey will be mailed each quarter to a random cross section of more than 2,000 investors who have been active in San Diego real estate during the past five years. Results of the TFN survey will be released to the public.

"The San Diego real estate market has undergone tremendous changes in recent years and the survey is designed to measure both current attitudes toward real estate as an investment and its potential for the future," said Nicol, who has worked in the local real estate market for 18 years and has been president of the diversified real estate brokerage since 1970. "We felt a quarterly survey would be frequent enough to see changes in sentiment. We are also asking the respondents to pinpoint anticipated interest rates, market strengths, estimated returns on their investment and basic timing during the upcoming two years."

Nicol said it is hoped that the TFN survey will serve as something of a leading indicator for San Diego investors, companies and lending institutions.

"The survey should be a good one because it will go to the people who had their money on the line during the past five years," he said. "They may not have their doctorates in economics or be in charge of large consulting firms, but most know exactly how their investments fared and what they are planning to do in the next few years. This is the kind of grassroots economics that we feel has a high degree of credibility."

"This part of the survey will help us in modifying and improving our services to the community," said Nicol. "As the market changes, so do the services required to successfully operate and prosper. If we know what we are doing right and wrong and what people expect to happen in real estate, we can adjust to meet their needs."

Thomas-Fletcher-Nicol Co. had its origins in 1968 when Paul Thomas, the current chairman, founded the Thomas & Fletcher Co. It became Thomas-Fletcher-Nicol Co. in 1970 when Nicol joined the company to direct brokerage operations. TFN specializes in commercial and industrial sales and leasing. It is based in the Fifth Avenue Financial Centre, 2550 Fifth Avenue, San Diego. □

FARROW REALTORS NAMES NEW ASSOCIATES

Seven new realtor associates have joined Farrow Realtors in its Carlsbad headquarters office, Jerry Farrow, president of the 33-year-old firm, has announced.

They are Loretta Callahan, Ira Barnes, Alice Farrow, Judy Lewis, Donna Rosenstock, Dorothy Oswald and Dave Grafft.

Farrow Realtors moved its headquarters office from Orange County to Carlsbad last September. The office is at 4901 El Camino Real.

Farrow reported that sales in the last three months of 1975 here increased 143 per cent over those for the same period in 1974, and that January sales exceeded \$1 million. It was the first million-dollar month in the firm's North County operation, he said.

About 75 per cent of Farrow Realtors sales are single-family dwellings, Farrow said. Seventeen per cent were to buyers from Orange County and 10 per cent to buyers who were from areas outside San Diego and Orange Counties.

Seventy-three per cent of the buyers were residents of San Diego County.

Average sales price of homes sold the last three months of 1975 was \$48,700, an increase of \$3,000 over the same period of 1974. □

FAST FOOD CENTER DEVELOPMENT PLANNED

H. L. Troutman, vice president of Avco Community Developers, Inc. (ACD) announced the development of a new fast food complex in the Rancho Bernardo Town Center.

Rancho Bernardo Fast Food Center, an affiliate of Miramar Development Co. of San Diego has purchased a two-acre parcel in the town center. Developers and general partners of Rancho Bernardo Fast Food Center are William Carstens and Stanely C. Swartz.

"Construction on the fast food center, which will include several fast-food operations, is scheduled to begin within 90 days as the leases are finalized," Troutman said.

The Rancho Bernardo Town Center, being developed on a 110-acre site in Rancho Bernardo, is a commercial and administrative center for the 5800-acre new town. The Bernardo Town Center provides for office buildings, convenience shopping, retail and high fashion stores and recreational facilities. There are eight financial institutions, some under construction, a post office, and Von's shopping center in the Bernardo Town Center.



is pleased to announce
the opening of their

new

Rancho Bernardo Office
covering

Rancho Bernardo
Green Valley
Stoneridge
Valle Verde
Silver Saddle
High Valley
Highland Valley

485-6280
& 271-9040

16776 Bernardo Center Drive
Suite 109

Member/Homes For Living

NORTH COUNTY LIVING MAGAZINE'S REAL ESTATE RAP-UP



IS THE HOME
FOR YOUR
IMPORTANT
LISTINGS

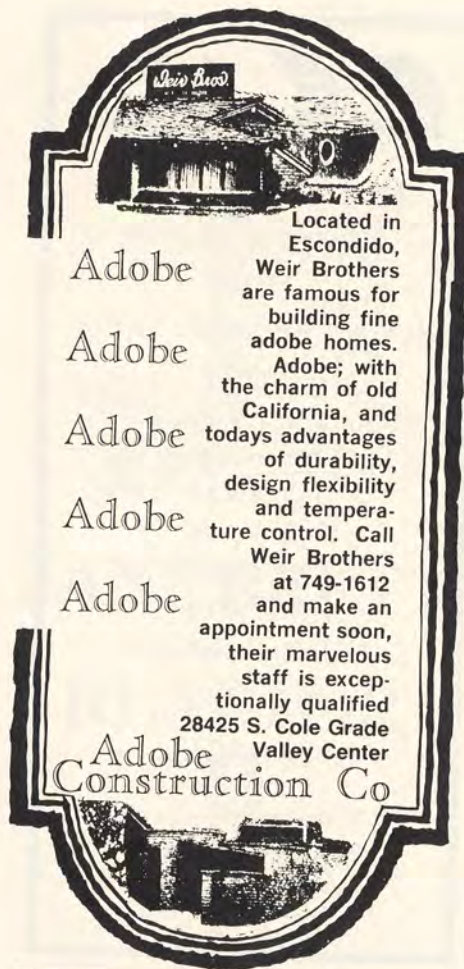

Located in Escondido, Weir Brothers are famous for building fine adobe homes. Adobe; with the charm of old California, and today's advantages of durability, design flexibility and temperature control. Call Weir Brothers at 749-1612 and make an appointment soon, their marvelous staff is exceptionally qualified 28425 S. Cole Grade Valley Center

Adobe Construction Co

Two Young Businessmen
Seek to Rent
Two Homes
in North County!

**FAMILY HOMES
WANTED
TO RENT**
6 mo.-1 yr.

We would like to rent two roomy, 4 bedroom, den, kitchen, dining, and living room homes in the North County. Large lot desired. We intend to rent for 6 mos. to 1 year. We each have families and will treat the homes as if they were our own.

**Please Reply To:
HOUSES WANTED**

BOX Q,
Rancho Santa Fe, California
92067

P.S. August 1st, 1976 will be the date of occupancy.

REAL ESTATE RAP-UP

AGENT NAMED FOR \$1-MILLION PARCEL

Thomas-Fletcher-Nicol Co. has been named exclusive agent on a \$1-million, 50-acre hotel and recreational center site on Interstate 5 near the International Border at Tijuana.

Joe Smith, TFN sales associate, said the property was being held by a partnership for development into a major traveler-oriented complex. But it was decided to dissolve the partnership and neither of the principals desired to continue with the original plans, he said.

"They had prepared a feasibility study on its usage as a complete tourist center with hotel, restaurants and recreational facilities, plus a campground on the back part of the property for recreational vehicles and campers," Smith said. "They posted the improvement, school and indemnity bonds and paid park fees on the property, which fronts on Dairy Mart Road at the Interstate 5 off ramp."

The site is being offered by TFN as two adjoining parcels, he said. The front 23 acres is zoned for hotels, motels and related amenities. The back 27 acres could be used for recreational use, including riding stables or a small golf course.

Thomas-Fletcher-Nicol Co., exclusive listing broker, is a diversified San Diego real estate company with offices in the Fifth Avenue Financial Centre, 2550 Fifth Avenue.

SKYLOFT SALES DIRECTOR NAMED

Veronica Hicks has joined the Ramos/Jensen Company as director of sales for Skyloft, according to Ronald J. Ramos, president of the Ramos/Jensen Company, general partner of the planned residential community of Skyloft.

Ms. Hicks has a six year background in real estate in the San Diego area. Prior to joining the Ramos/Jensen Company, she was associated with McMillin Realty, where she won their outstanding salesperson award for 1974.

Skyloft is a \$7 million development of luxury three and four bedroom homes located off La Costa Boulevard just east of Interstate 8 in Leucadia. The project is planned for a total of 98 custom quality homes in the \$59,000 to \$79,000 price range. Sales are now well under way.

PAPAGAYO CELEBRATES GRAND OPENING

Grand opening celebrations were recently held at Papagayo by the Bay, a 340-unit luxury condominium development in Carlsbad, according to Larry D. Hunts, AIA, architect and developer of the 25-acre community.

Two model homes are open in the initial phase of construction which includes 50 completed residences. Hunts noted that an additional 48 units are planned for the second phase of this \$32.4 million development.

Papagayo, meaning parrot in Spanish, is the unusual name for this coastal community where a parrot is the trademark and the streets are Spanish-named for tropical birds. "Once this was part of a Mexican land grant and we've tried to preserve some of the historical flavor," Hunts said.

Years ago, the land was heavily planted with macadamia, peach, plum, citrus, and avocado trees. Two years of careful step-by-step planning preceding the construction of Papagayo has saved such trees and made the development a community with 60% of the land consisting of handsomely landscaped terrain.

Eight floor plans, available in 1- and 2-level designs include two bedrooms with 2 to 2½ baths and feature up to 1,750 square feet. Located on Agua Hedionda Lagoon, many units offer views of both the historic lagoon and the Pacific. Prices range from \$44,950 to \$85,000.

Four recreation areas to be interspersed throughout the community include saunas, exercise rooms, swimming pools, jacuzzis and recreation rooms. "In addition to the on-site recreational amenities, residents can enjoy swimming, fishing and surfing at Carlsbad State Beach," Hunts noted, "and, Oceanside, just north of Carlsbad, offers mooring for oceangoing boats, and deep-sea fishing. Nearby Palomar Airport, with a 4,700 foot runway, can accommodate small jet aircraft."

The development is among the very first communities built in conformance with the State Energy Conservation laws as well as the interior-exterior Sound Control laws.

Papagayo by the Bay is located at Chiquapin Avenue and Jefferson Street, just off Interstate 5 and reachable by the Tamarack exit.

CONSTRUCTION BEGINS ON COMMERCIAL CENTER

Construction has begun on the first commercial building at San Diego Country Estates.

Community co-developer Bill Watt said this is the first structure in a planned 14-acre shopping center to be developed near the entrance to the community on the northwest corner of Gunn Stage Road and San Vicente Blvd. The center will eventually serve a community of 10,000 residents.

Designed by Leon Glucksman and Associates, AIA of Los Angeles, the one-story ranch-style building will provide 12,000 square feet of retail space. Watt Industries is general contractor.

When completed in July, 1976, the \$350,000 building is expected to house a restaurant, drug store, gift shop, liquor store, delicatessen, real estate office, cleaners, laundry, beauty salon, barber shop, doctor's office and dentist's office.

San Diego Country Estates is a 3,200-acre resort community in the San Vicente Valley, 44 miles northeast of San Diego and four miles east of Ramona. It is reached via Highway 67 from San Diego and via Interstate 5 and Highway 78 from Los Angeles.

SKYLOFT RESIDENTS ELECTED

Two residents of the new community of Skyloft have been elected to the Board of Governors of the Skyloft Homeowners Protective Association. They are Jack S. Green, director of instruction for the Oceanside School District, and Frances Powell, elected secretary.

Green's family was the first to move into Skyloft. His wife Genie is a teacher in the Encinitas school system, which serves Skyloft, and they have a 4½ year old son, Ryan.

Green is delighted with their Skyloft home and considers it one of the best areas in California.

Mrs. Powell, a real estate broker specializing in real estate investment, and her husband Gene, who is retired from the Navy, have been residents of Skyloft since Sept. 1. Mrs. Powell says she is looking forward to serving on the board, also. "I have quite a bit of experience living in communities with common areas," she said. "It can be a beautiful way of life, and I feel that my experience can help prevent some of the problems."

Mrs. Powell and Mr. Green are the first resident members of the Skyloft Board of Governors. Ronald J. Ramos, president of Ramos/Jensen, which built Skyloft, serves as president of the board.

ENCINITAS DEVELOPMENT SALES REPORTED

Sales have passed the 50 per cent mark at the 65-home Unit II of New Summerfield in Encinitas, according to the developer.

Robert M. Allan, president of Standard Pacific of San Diego, said sales reached 33 recently in the construction increment that opened Jan. 25. Construction also is about at the halfway point, with completion and occupancy in Unit III set for mid-June.

The first two units at New Summerfield, comprising 39 and 44 homes, were sold out before sales were initiated in Unit III.

The one-level single-family homes at New Summerfield are built on terraced lots of 10,000 square feet and up, with 20 to 40 feet of space between houses and pool-size rear yards.

"The terracing and separation of the homes promote privacy as well as enhancing the views of the surrounding countryside," Allan said.

Designed to blend compatibly into the rustic surroundings, New Summerfield is being built on 65 acres adjacent to El Camino Real, less than two miles from the Encinitas beachfront.

The \$10.2-million development is reached by driving east from Interstate 5 on Encinitas Boulevard for 1½ miles to El Camino Real. A model-home complex is open 10 a.m. till dusk seven days a week.

With exteriors utilizing masonry, lomastone, rough-sawn timber, and cedar shakes, the homes offer four floor plans of three and four bedrooms with two baths and up to 1,956 interior square feet. There are three elevations available for each plan, all employing shake roofs. Prices range from \$48,990 to \$54,990.

Features of the New Summerfield homes are attached oversized two-car garages with direct access to the home, double-door front entries, antique-brass-finish lever door handles, pre-wired cable-television outlets, fireplaces suitable for either gas-log or wood, copper plumbing throughout.

Kitchens are separated from garden patios by walls of glass and highlight pass-through serving bars, pantries, a choice of extra-large ceramic tile for countertops, stained-ash cabinetry, porcelain-finish cast-iron sinks, and an array of built-in appliances including dishwasher with rinse injector, disposer, a 36-inch-wide range with 42-inch hood, and a separate glass-door continuous-cleaning oven.

Standard Pacific Corp., one of California's leading builders of residential communities since 1956, has been building in San Diego County for five years.

Virginia Blesso Real Estate
756-1659

Post Office Box 571
Paseo Delicias
Rancho Santa Fe, California
92067



R. M. CLOTFELTER
LICENSED REAL ESTATE BROKER
in Rancho Santa Fe

Since 1931

IN RANCHO SANTA FE
Country Homes
and
Homesites

REAL ESTATE INSURANCE

756-2422

**SHIRLEY KEETH
REAL ESTATE**



Shirley Khanna
Maheshwar Khanna
Rip Wasser
Patricia Driver
756-3706

Rancho Santa Fe, CA
Paseo Delicias at La Granada

REAL ESTATE RAP-UP

COLDWELL BANKER TO MANAGE COMMERCIAL CENTER

The appointment of Coldwell Banker Property Management Co. to manage the 20-store, 13.24-acre Rancho Bernardo Town Center Shopping Plaza has been announced by David M. Campbell of the firm's San Diego office.

Campbell said the center, opened in November of 1974, is part of the 114-acre Bernardo Town Center, which has been master-planned as the commercial heart of Rancho Bernardo.

He said plans for the Bernardo complex call for the addition of a fast food outlet, an automotive center, professional and corporate offices, a number of financial institutions and several quality restaurants.

Presently operating at 100 per cent occupancy, the Town Center Shopping Plaza is anchored by a 60,000 square foot Von's Supermarket as well as a

17,000 square foot Nahas Rathbuns store and a Sprouse Reitz outlet of 15,400 square feet. All told, the 20 occupied stores are utilizing a total of 117,106 square feet.

Designed by the Los Angeles architectural and planning firm of Lott, Collins, De Revere & Associates, the Town Center Shopping Plaza recently was sold in a transaction negotiated by Rod Myers of the San Diego office of Coldwell Banker Commercial Brokerage Co. □

COLDWELL BANKER NAMES VICE PRESIDENT

Brent F. Howell, a member of the Southern California regional marketing staff of Coldwell Banker Commercial Brokerage Company, has been named a vice president of the large real estate firm. Announcement of the appointment was made by Jess C. Wilson, Jr., executive vice president, who said

that Howell will continue, as directed by Robert A. Hatch, senior vice president and head of the firm's marketing staff, to assist the company's full-time sales and leasing personnel in negotiating and marketing of commercial retail properties.

Howell, who was appointed to his present assignment last July, brought to his position an 11-year sales and leasing career in which he specialized in regional shopping center properties and tenant representation. During that time, he was leasing team captain for Los Cerritos Mall, Santa Anita Fashion Park and Westminster Mall and was active on the leasing teams for Del Amo Fashion Square, Fox Hills Mall and the Promenade. He also has extensive leasing experience in neighborhood shopping centers and general retail sales and leasing. Howell was a consistently high producing salesman in the firm's Beverly Hills office where he was named an associate vice president in 1974 prior to becoming a member of the company's management team.

A graduate of Claremont Men's College, where he earned a bachelor of arts degree, Howell also attended UCLA where he was awarded a master of business administration degree with a specialization in managerial finance. □

EVERYWHERE YOU LOOK — BEAUTY!

A soft, unforgettable view of the California mountains

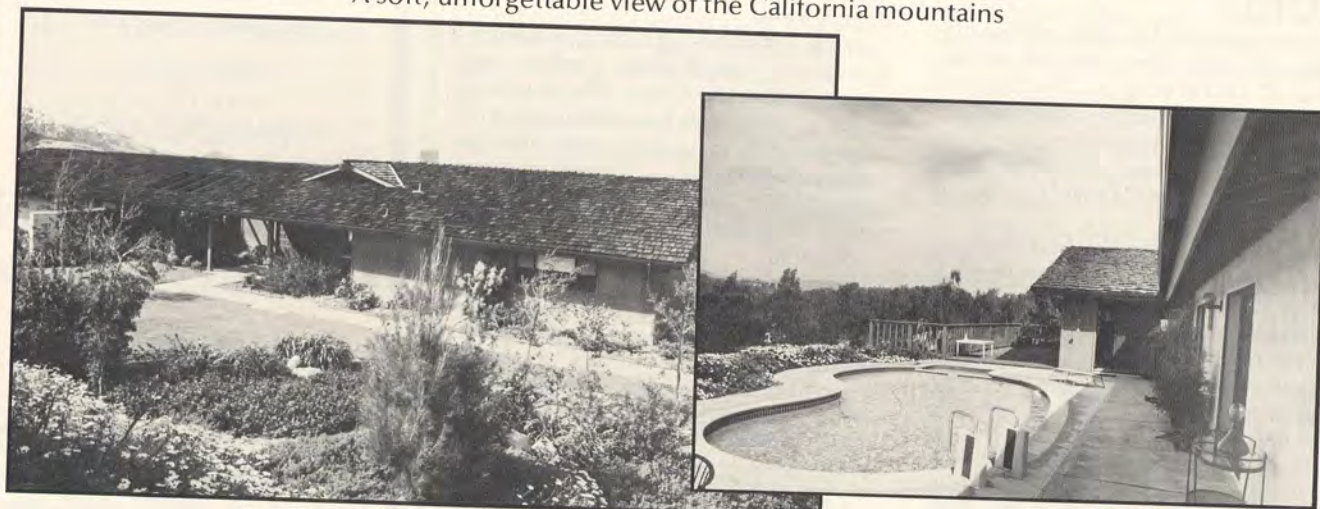

For the selective buyer, a home of quiet elegance with the following amenities:

2½ acre grounds
Pool, jacuzzi
3 bedrooms, 2½ baths

Horse trails on property
Generous room for corral and tennis court
All under sprinkler system

Electric heat
Wired for music and intercom
Fireplace



Offered by John Nichols, of:

Coldwell Banker
RESIDENTIAL BROKERAGE COMPANY
A COLDWELL BANKER COMPANY

930 Prospect Street, La Jolla

Phone (714) 459-3851

THE FINEST IN
PROFESSIONAL
REAL ESTATE
SERVICE
SINCE 1906.

REAL ESTATE

LOMAS SANTA FE TO ADD COURTS

Plans to construct four new tennis courts and two teaching alleys have been announced by the Lomas Santa Fe Country Club.

There are currently eight courts and with the completion of the new courts and teaching alleys in August, the Lomas Santa Fe Country Club will have one of the largest and most complete tennis facilities in north San Diego County.

"The additional courts will help us meet the growing demand for tennis memberships, and will allow us to expand our junior program," Vic Dhooge, club tennis director said.

The Club's junior program consists of clinics, round-robin tournaments, singles and doubles championship tournaments, parent-junior tournaments and participation in the World Team Junior Tennis League. There will also be special evening social events for juniors twice a month during the summer.

Adult events and activities include the Club doubles championship tournament in May, the singles championship tournament in October, team play in the North County Men's and Women's Leagues, men's and women's ladders, monthly twilight tennis socials, and weekly round-robin play for men and women.

Private and group instruction is available from Dhooge, former Michigan State University and Junior Davis Cup player, and his assistant pros Bob Jackson and Nicki Cloyes. □



Getting a head start on construction of four new tennis courts at the Lomas Santa Fe Country Club is James Bullock, second from left, tennis committee chairman. Looking on are Club Vice President and General Manager Jack L. Austin, left; Vic Dhooge, tennis director, and Nicki Cloyes, assistant tennis pro.

an accent on Elegance



Our new two-story, four-bedroom plan is designed for people who are looking for a gracious and comfortable home in a prestigious location.

The living room and dining room are ideally suited for formal entertaining, and there's a separate family room with woodburning fireplace for casual activities; a guest room and full bath downstairs; and a deluxe kitchen and breakfast nook opening to a patio area.

Upstairs you will find two generously proportioned bedrooms in addition to a master suite that has its own bath with roman tub, a separate dressing area, large walk-in closet and sitting area for quiet hours of relaxation.

These elegant homes, many with panoramic views of the countryside, mountains or ocean, are located in San Elijo Hills, a quiet, secluded neighborhood within the charming community of Lomas Santa Fe.

Swimming, golf, tennis and a large park are within walking distance. Excellent schools and shopping are nearby. Beaches are only two or three minutes away.

If you're looking for a gracious home in a special location, we invite you to inspect our two-story, four-bedroom plan as well as our four other plans. Furnished models are open daily, 10 a.m. to 6 p.m. Phone 755-5114.

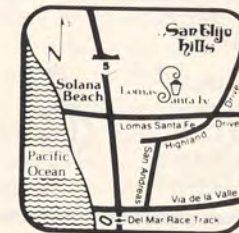

From Interstate 5, go east on Lomas Santa Fe Drive one mile to Highland Drive and turn left.



**San Elijo
hills**

IN BEAUTIFUL LOMAS SANTA FE

BOOKS IN PRINT

CALIFORNIA BEST-SELLERS

- | | |
|--|---|
| 1 1876 by Gore Vidal | GENERAL |
| 2 TRINITY by Leon Uris | 1 THE PEOPLE'S ALMANAC by David Wallechinsky and Irving Wallace |
| 3 THE "R" DOCUMENT by Irving Wallace | 2 THE FINAL DAYS by Bob Woodward and Carl Bernstein |
| 4 THE CHOIRBOYS by Joseph Wambaugh | 3 DORIS DAY: HER OWN STORY by A. E. Hotchner |
| 5 THE GEMINI CONTENDERS by Robert Ludlum | 4 WORLD OF OUR FATHERS by Irving Howe |
| 6 THE BOYS FROM BRAZIL by Ira Levin | 5 THE RUSSIANS by Hedrick Smith |
| 7 CURTAIN by Agatha Christie | 6 A BOOK by Desi Arnaz |
| 8 SAVING THE QUEEN by William F. Buckley Jr. | 7 SPANDAU: THE SECRET DIARIES by Albert Speer |
| 9 STRANGER IN THE MIRROR by Sidney Sheldon | 8 EST by Adelaide Bry |
| 10 NIGHTWORK by Irwin Shaw | |

- 9 WINNING THROUGH INTIMIDATION by Robert Ringer
- 10 THE RELAXATION RESPONSE by Herbert Benson with Miriam Klipper

NATIONAL BEST-SELLERS FICTION

- 1876 by Gore Vidal
- CURTAIN by Agatha Christie
- SAVING THE QUEEN by William F. Buckley Jr.
- TRINITY by Leon Uris
- THE CHOIRBOYS by Joseph Wambaugh
- THE BOYS FROM BRAZIL by Ira Levin
- RAGTIME by E. L. Doctorow
- THE GEMINI CONTENDERS by Robert Ludlum
- THE GREEK TREASURE by Irving Stone
- THE "R" DOCUMENT by Irving Wallace

GENERAL

- DORIS DAY: HER OWN STORY by A. E. Hotchner
- THE RUSSIANS by Hedrick Smith
- WORLD OF OUR FATHERS by Irving Howe
- ANGELS by Billy Graham
- WINNING THROUGH INTIMIDATION by Robert Ringer
- BRING ON THE EMPTY HORSES by David Niven
- THE ADAMS CHRONICLES by Jack Shepard
- SPANDAU: THE SECRET DIARIES by Albert Speer
- THE RELAXATION RESPONSE by Herbert Benson with Miriam Klipper
- THE FLOWER AND THE NETTLE by Anne Morrow Lindbergh

ASTROLOGY FORECAST

by Jean Farman

TAURUS (April 21-May 21)

Don't just sit there! Get out among 'em and make the most of this marvelous month while luck and love smile your way. 'Tis the time to push for what you want, to achieve hopes and wishes close to your heart. Seeds planted now (ideas, projects, etc) bring bountiful crops later on. While given the chance to make terrific progress during May, don't overlook some warning signals: transportation could give problems in unexpected ways; wiring, appliances, electric gadgets could do more than give you a shock; your stubborn streak causes sticky situations with partners or key associates — you may have to cooperate or separate! Taurus celebs: Audrey Hepburn, Joe Louis, Robert Morse.

GEMINI (May 22-June 21)

Whoa, Gemini! Collect yourself and settle down to one thing at a time. Too many irons in the fire will dissipate needed energy and finances right before your very eyes. People who work for you or with you could give you reason to tear your hair. Be super careful while in motion around the 23rd. Gemini star: Dorothy McGuire.

CANCER (June 22-July 22)

The merry month of May brings happiness to many Moon Children. Some of those fondest hopes and wishes are liable to be realized. Social life is on a vibrant upswing. Friends offer support and encouragement. Don't let your head grow too big for your crown as fans are fickle and your audience could turn sour. Moon child: Billy Wilder

LEO (July 23-August 22)

Get ready Leo, change is on its way and beating a heavy path to your front door. Career, professional interests and activities outside of the home are under a bright shiny star. Social contacts do much to further your progress. Go ahead with travel plans after the 23rd. Those family members still need careful handling. Leo lad: George Hamilton.

VIRGO (August 23-September 23)

Powerful urges to fly the coop are still haunting many Virgos. Do consider all the goods and bads before making that final decision to pull up roots. Decision making time should be held in abeyance until after June 3rd. You've been finding out life is quite a challenge — but you ain't seen nothin' yet! Virgo celeb: Dennis James.

LIBRA (September 24-October 23)

Bury all thoughts of extravagant spending during the month of May. If you don't, you'll be paying now and weeping crocodile tears later! If romance is knocking loudly at your door, proceed slowly with great caution. Don't go overboard! This could turn out to be a one-sided affair with you on the losing end. Libra music man: Ray Charles.

SCORPIO (October 24-November 22)

Impatience will only give you a case of nervous hives! Sit back, relax, count the bubbles in your wine while partners and key associates spin their wheels in the sand. It won't be long before they call on you for advice and direction. Self-indulgence at the table during May will destroy your sexy waistline. Scorpio talent: Jack Kelly.

SAGITTARIUS (November 23-December 20)

A stitch in time may save nine but Sagittarians will probably be more inclined to revamp the entire wardrobe closet during May. Some of your sign may acquire new employees, household help or possibly a new pet. A super fun vacation could be available to you near the 27th. Foreign lands have interesting magnetic appeal. Sagittarian star: Rita Moreno.

CAPRICORN (December 21-January 20)

Use your head, not your heart, when someone pleads for financial assistance. If you submit to teary demands you might as well kiss off whatever is loaned. Be especially discreet with your public image as there are those who would love to see you stub your toe! Opportunity to display your talents comes at month-end. Capricorn celeb: Kathleen Crowley.

AQUARIUS (January 21-February 18)

Busy Aquarians had better take those vitamins and get all the rest their bodies require. You can't do much of anything if vitality and health is run down. Your humble hacienda may be sparking the urge to redecorate and beautify. You are apt to discover some very fine bargains for the home this month. Aquarian talent: Katharine Ross

PISCES (February 19-March 20)

Perk up Pisces — now's the time to put those big ideas regarding career, profession or activities outside the home into action. Authority figures are receptive and can be swayed to your thinking. Pisces parents may have reason to both laugh and cry over offspring during May. Create happiness by doing something nice for your friends. Pisces celeb: Richard Beymer.

ARIES (March 21-April 20)

If gifted with a pot of gold, don't let new financial independence cause you to blow it on a game of chance. Flying high and feeling generous, be sure to stash some cash away to protect future security for self and those dependent upon you. Don't waste time with people who depress and discourage. Aries celeb: Alec Guinness.

UPCO

North County's Largest Livestock-Horse-Pet Supply Store!

ANIMAL SUPPLIES SUPERMARKET
432 North Quince 743-2102

HORSE EQUIPMENT
English & Western Saddles, Bridles, Silver Vaccines for: Tetanus, Encephalomyelitis, Equine Flu, Strangles



LIVESTOCK Remedies & Vaccines
Cattle-Sheep Goats-Swine Halters-Feeders Instruments Pen-strep Tylan-Sulfas



PET SUPPLY HEADQUARTERS

No-Bark Collars Distemper Vaccines Vitamins-Foods



Science Diets Collars-Leads Shipping Cages Automatic Waterers Flea-Tick Products



UPCO ANIMAL SUPPLIES SUPERMARKETS
432 NORTH QUINCE IN ESCONDIDO 743-2102
8366 LA MESA BOULEVARD IN LA MESA 469-2112

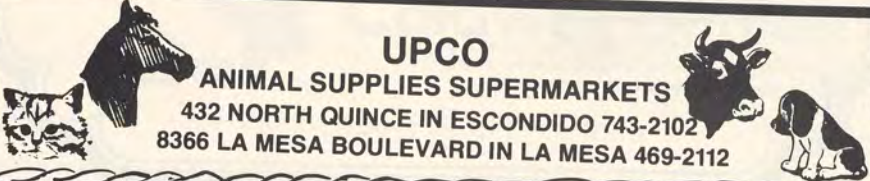

GROSSMAN ON SPORTS



A LOVE MATCH: LAVER AND TEAM TENNIS

You calculate the motivation on the part of Mr. Rod Laver, the tennis artist, for capitulating to the chum of the San Diego Friars of World Team Tennis and you conclude that money wasn't everything.

This is a man who already has made his million and assorted loose change from the sport. At thirty and seven years he needs road trips like a pain in

Rod Laver, tennis' all-time leading money winner, has joined the San Diego Friar's roster.

the elbow. His home life is a source of much pleasure and any time he needs a game, there's always Jimmy Connors ready for a rematch.

"I like the challenge of participating in a team sport," Laver explained. "And team tennis certainly is a team sport."

Despite its accelerated growth, tennis hasn't quite penetrated the life of

most Americans to the extent, say, of All in the Family.

"The United States is a team oriented country," Laver points out. "Look at the major sports. The only one that isn't team oriented now is golf."

That is not to suggest, Laver promptly says, that the individual tennis player will be less of a personality because of team allegiance.

"Football is completely a team sport, but Joe Namath doesn't suffer as an individual because he is a member of the Jets," Laver argues.

"It is going to take some time before the public becomes tuned to the team flavor of tennis. It's not going to happen overnight. But I'm confident that the World Team Tennis format is solid and its appeal is strong."

As the only person to have won the sport's four major titles twice in the same year (U.S. Open, Wimbledon, French and Australian), Laver does not require the WTT to establish his impact upon the sport. Four times he captured the U.S. Pro Indoor title, and his career earnings from tournaments exceed \$1.5 million. You don't bank that figure by losing in the opening rounds.

G. Allan Kingston, the Friars' resident genius, has announced that Laver's contract encourages the belief that he is the highest paid player in WTT. Rod does not blush because of such comment but considers his association with San Diego beneficial in other ways.

"At the airport the morning of the announcement I was joining the Friars, people stopped me and asked what I was doing in San Diego," Laver said. "I told them I was on my way to sign with the Friars. They said 'great, we'll be out to see you.'"

"It is very gratifying to know that you'll be playing in a city where the people care and are genuinely interested in tennis and their team."

At his press conference, Rod suggested that the charms of San Diego County and particularly Rancho Santa Fe were such that he and his wife, Mary, were considering moving from their home in Corona del Mar. Immediately, real estate people who would not know the difference between a drop shot and a drop out telephoned the Lavers and advised (1) they were Friars season ticket holders and (2) they had a dandy house for sale in their portfolio.

"Actually, the real estate people were very nice," Laver said. "Some even sent pictures of their homes. But there sure were a lot of them for a place as small as Rancho Santa Fe."

There is a special grace to Laver, a quality style that is evident both in the man and the player. He moves with a

short, choppy gait and delivers his conversation in a happy, but swift cadence.

"My first win at Wimbledon was the toughest but the most memorable victory of my career," he said. "The atmosphere, the pressure of that event are beyond comprehension. It's simply nerve wracking."

"I've always done well at Wimbledon. I seem to concentrate better there. I guess I'm afraid of making an ass of myself in front of so many people."

His career is so unique that it spans the Davis Cup matches of 1962 as well as those ten years later. It may be remembered that the 1972 Davis Cup competition signaled the conclusion of the United States supremacy as Laver teamed with John Newcombe to deliver the prize back to Australia.

"In a very real way, Davis Cup play is very similar to the pressure of World Team Tennis," Laver said. "You're playing for a team but because every point of every game is vital, the individual performance still is the key to the result."

"I've always been the type of player who goes for broke, who wants to move to the front and stay there. When you're involved in team play, you have to adopt this attitude and it creates a very exciting atmosphere."

In its first season, WTT encouraged its patrons to participate vocally to whatever extent desired. In other words, if your favorite singles player was netting too many easy backhands, you could encourage the coach to send a hook for him. There were occasions, one is told, when Billie Jean King was the recipient of prose normally reserved for Pete Rose in Dodger Stadium.

"A little flair is good for the sport once in awhile," Laver concedes, "but team tennis doesn't really require poor manners from the fans in order to be successful at the gate. On the other hand, I'm not in favor of complete silence. Some noise is inspirational."

Laver's consideration of conversation at tennis matches is much like that of the young boy who refused to say anything to his parents for the first six years of his life. The youngster's silence could not be broken although his parents enlisted the aid of the most respected professional help.

Suddenly, one morning at breakfast, the boy without warning shouted: "Damn it, the toast is cold."

His parents were both astonished and delighted.

"You are able to speak," they rejoiced to their son, "that's wonderful. But how come it took you six years to say something."

"Up until now," the boy replied, "everything has been all right."



ERNIE COWAN PHOTOGRAPHY
333 S. Juniper Street
Escondido, California 92025
(714) 741-0331

Escondido Linoleum & Carpet, Inc.

A Complete Floor Covering Center

Carpeting • Resilient Tile
Vinyl Floor Covering • Formica

745-5821

462 North Elm
Escondido



"Our 30th Year in Business"

Escondido Drapery Studio, Inc.

Draperies made in our
own workroom

Draperies
Woven Woods
Levelors
Bedspreads
Shutters
Upholstery

745-1127

460 Elm Escondido



CLASSICS ON RECORD

by Troy Reynolds

Dvorak and Tchaikovsky Serenades for Strings (Angel S-37045), performed by the English Chamber Orchestra, Daniel Barenboim conducting: Serenades should be, if nothing else, serene, but these two are blessed with particularly moving dance movements that lose too much of their vitality and punch when handled as delicately and sweetly as they are here. Otherwise, Barenboim offers more than just serenity, especially in the massive, moody first movement of the Tchaikovsky. A grand and stately introduction is followed by the movement proper, which vacillates between two *allegro* themes, one seething, the other bouncing with shared energy.

Slavonic Dances, Op. 72, with the Overture "My Home," Op. 62, both by Antonin Dvorak (Deutsche Grammophon 2530 593), performed by the Varian Radio Symphony Orchestra, Rafael Kubelik conducting: Any idea that Dvorak is in and of himself as sac-

charine as Barenboim would have us believe is quickly dispelled on this recording. The first of these dances, a mazurka, opens with a theme as spicy and sprightly and *molto vivace* as they come, with flutes trilling, cymbals clashing and strings racing, and closes with the characteristic heartbeat-like triple burst on the timpani. Kubelik and his players handle the short, airy inter-sectional conversations, most notably those of the third dance and the Overture, with more facility than they do the fully orchestrated episodes, which seem too fast in tempo, and lose their grace and cohesion in a rush to be done with.

The Rite of Spring by Igor Stravinsky (London STS 15318), performed by the Paris Conservatoire Orchestra, Pierre Monteaux conducting: A timely re-release and power rendition of Stravinsky's most appealing work, this recording is an adventure in playful interpretation of the simple but serpentine themes that wind around the highly developed rhythms that

hold this piece together. The occasional dissonant, pounding harmonic passages are crisp and solid, and if the intended musical agitation of the repetitive, caconic melodies at times degenerates into orchestral confusion, the effect isn't so removed from the intention to be bothersome.

Concertos for Three Harpsichords and Harpsichord Concerto No. 8, by Johann Sebastian Bach (Das Alte Werk SAWT 9458-A), performed by Gustav Leonhardt, Anneke Uitenbosch, Alan Curtis and Das Leonhardt-Consort: The harpsichord, a basically limited instrument without much tonal or dynamic versatility, is made to come to life on this provocative, well-recorded disc. The harpsichord scores become finely-tuned, gleeful excursions into the fluttering arpeggios, scales and trill that make Bach both so easy to listen to and difficult to play. The accompanying coloration is at times too colorful, becoming overshadowing rather than supplemental when perhaps more restraint could be shown.

Baroque Music for Recorders (Nonesuch H-71064), performed by the Concentus Musicus of Denmark, K. K. and A. H. Mathiesen, conductors: Two sets of dances and three sonatas are included in the potpourri of ensemble music. Erasmus Widmann's "Galliarde und Tanze", published in his *Musikalischer Tugendtspiegel*, is seven lively, flowery tunes written for four parts and performed *ad libitum* on recorders alone. More harmonic and less flowing are the five selections from the *Polnischer und Teutscher Art Tanze* of Christoph Demantius. The three sonatas are all of later origins, and for alto recorder with small ensemble accompaniment. Jean Baptiste Loeillet's Sonata in A minor for Recorder and Continuo, Op. 1, No. 4, by Georg F. Handel starts with a pensive, listless *Larghetto*, but picks up dramatically in the second movement, with much scaling of chords and ornamentation of notes. The *Adagio* is stately and barren in contrast, while the final *Allegro* is perky and free-form, modulating on occasions when you might least expect it.

Richard Strauss Quartet for Piano and Strings in C Minor, Op. 13 (Desmar DSM 1002), performed by Irma Vallecillo and the Los Angeles String Trio: It's easy to make Romantic music sound romantic, and blossoming musicians recording for a new label might be expected to take this path of least resistance. Gratefully, these have not, but neither do they come up with a distinctive, fresh interpretive approach of their own. The musicianship is precise, but not fulfilling. No mistake nor inroads are made.



BEETHOVEN

is alive and living on **KFSD-FM94.1**

"The Concert Music Station for San Diego"

DEDERA ON LIVING

THE FIFTH OF MAY IS NOT THE FOURTH OF JULY

You may, on the fifth of May, have gone to Tijuana and drunk a small dark beer and watched the parade of 125,000: 30 bands, battalions of troops, squadrons of motorcycles.

The flooded, turbulent river of humanity surges along Avenida Revolucion. Someone estimates there are 20,000 flags in the Tijuana pageant. Hundreds of thousands more citizens are spectators; most active, the schoolchildren chanting:

"Cinco. Cinco. Cinco!"

You may sip the beer, but do not order a cream puff.

A cream puff is a French pastry. And this day, anything French is unwelcome. If you are so ill-advised as to arrive in a Citroen smelling of cologne and wearing a beret, you might be lynched.

No day of the year excites more pride in Mexico than Cinco de Mayo. On that day in 1862 there occurred a battle that the Mexicans could not win, but did.

Costly internal strife had caused Mexico to seek loans from Europe. These debts were inherited by Benito Juarez when he took over Mexico City in 1861. Juarez was a self-made diplomat of pure Zapotec Indian blood. He was a man of the people. His people were starving, and his treasury was empty.

"First things first," he said of the debts. "First we must feed the people." He announced the postponement of repayment of the debts for two years.

England and Spain accepted the promise of Juarez that the debts would be paid in full, if late. But Napoleon III of France saw a chance to extend his empire while the United States was preoccupied with its own Civil War.

Napoleon was confident. His army of professionals, battle-hardened in the Crimean War, was the best in the world. Napoleon ordered the invasion.

The seaport of Veracruz fell like a toy town.

"We have such superiority of race, organization, and discipline," Gen. Lorence boasted to his emperor, "that as of today, at the head of 6,000 troops, Mexico is mine."

But Mexico City was a 10-day march into the interior. The route was difficult, through the mountain pass at Acultzingo, then by way of Orizaba and Puebla.

Every male Mexican between ages 20 and 60 was conscripted by Juarez. The men were hastily mustered into casual units. They armed themselves with whatever weapons were at hand: farm tools, machetes, fowling muskets.

The French, meeting only ineffective harassment approached Puebla on May 5. Scouts detected no strong forces in the area. The French approached Puebla confident of victory.

Abruptly the horizons were alive with charging Mexicans. Inferior in numbers, they fell upon the French with their hand weapons. Never before had Napoleon's army encountered such fury. Mexican torches ignited French powder magazines. The French were allowed no chance to organize a defense.

When the smoke and dust blew off the battlefield, French casualties could be counted in the thousands. In command of the terrible scene was a band of patriots astonished by their own success. The French were defeated for the first time in nearly 50 years.

That is Cinco de Mayo. All over modern Mexico it is an occasion for fiestas. Border cities of North America join in the anniversary. It is the Mexican day for remembering, "America for Americans."

And in Tijuana, you'll see 50,000 marchers from the labor unions. Clowns. Beauty queens. Dancers. Horsemen. Tableaux. Floats. And everywhere, the schoolchildren in new black-and-white shoes, shouting:

"Cinco. Cinco, Cinco!"

To you, a tourist, the torta and tamale lunch may be free. The police with the two flags on their shoulders will be especially hospitable. The kid that you pay 50 cents to watch your car may keep it from being scratched — that is, if it's a Ford.

And if you're not Jacques Yves Cousteau, Jean-Claude Killy or Brigitte Bardot.

CATALINA ISLAND BOYS CAMP
HOWLANDS LANDING
(A Private Cove) 49th Year
CATALINA ISLAND GIRLS CAMP
EMPIRE LANDING

24th Year
FOR YOUNGSTERS OF PARENTS WHO CARE

• SAILING • SURFING • FISHING
• TENNIS • CRAFTS • WATER SKIING
• BASEBALL • SWIMMING

DIRECTORS:

Joseph C. Robinson, Boys' Camp
George R. Taylor, Girls' Camp

FOR INFORMATION/EITHER CAMP:

TOTALOMA CLUB
10784-R SANTA MONICA BLVD.
LOS ANGELES 90025/213/474-2571

COOK? IN WHAT? WE HAVE IT!

San Diego's Only
Culinary Emporium

Inquire about our cooking classes.



4040 Goldfinch Street, San Diego • 299-8442

Exclusive does something
special for a man's suit

Yes, Exclusive-care for men does something for a suit that you can feel when you put the coat jacket on. Meticulous cleaning that's spotless quality in result — then — hand finished to put your suit back into its original shape. This is Exclusive's individual touch — a boon to your suit's good looks and your comfort.



Exclusive Cleaners

Call Collect



295-3156

3740 Park Boulevard, San Diego, California

"It costs no more
for service based on
long experience."



Encinitas Mortuary

340 Melrose Ave.
Encinitas, Calif.

Phone 753-1143

Because
you slept
in a

SLEEPER-LOUNGE



You will awaken completely refreshed
... more relaxed than you could ever
realize. Investigate this better way to
read in bed — more comfort to watch
T.V. — and restfully sleep.

TRY IT FOR YOURSELF



Sleeper Lounge

The first and finest electrically
adjustable bed for the home
IN SAN DIEGO COUNTY ONLY AT

Everett Stunz Co.

7644 Girard Avenue
Phone 459-3305
La Jolla

OWN A PIECE OF THE ROCK

Prudential



Estate Planning
Business Insurance
Mortgage Insurance
Life/Health/Annuities

ROBERT J. FISHER, C.L.U.
Rancho Bernardo 487-4843

GREEN SCENE

By Bob Clay

LOW MAINTENANCE GARDENS

Many of us, when we envision our ideal garden, think of masses of foliage. Our garden would have an orderly uncluttered look with a feeling of spaciousness. Of course our garden would take care of itself completely.

The climate of San Diego's North County is mild and is very favorable to plant growth. However, our soil is irritated by this mild climate. Successful gardening in mild climatic conditions is not as easy as it appears to be. Often, we think the cure to our garden ills is more maintenance. Surely a full time gardener, more water or fertilizer, more or larger plants and some pruning will bring us closer to the ideal.

This laborious route is effective only to a limited degree. It defeats the idea of a garden that will care for itself.

A handsome low-maintenance garden requires some grooming. More important is some careful in-depth planning from the sub-soil.

I'm not referring to "low maintenance tips" to simplify a maintenance problem, but how to avoid the maintenance problem in the first place.

A safe approach to preparing a planting plan is to note which plants are consistently strong growers in your area. This would be the group of plants that would make up the masses of foliage forming the backdrop to the low maintenance garden. This "wall of foliage" also gives dimension and boundaries to the area. Another function of the wall of foliage is to provide a backdrop to make the foreground plants stand out.

Take a walk or slow drive around your neighborhood looking for typical thriving plant types. Plants that are thriving under minimal maintenance are the ones to choose. Do not be misled by heavily groomed plants receiving professional care. Plants that can survive on neglect (or native shrubs indigenous to this area) are the ones to choose. It is important to note that plants that receive average maintenance are often killed by too much attention.

When making your choices, consider the area in your garden. Does the exposure to the sun and wind and light duplicate the environment in which the plant is now doing well? If so, you can expect the plant to respond and thrive. Check other plants of the same species for size, consistent color and

density. The plant can be readily identified by bringing a leaf sample to your local nurseryman.

Available garden books on the market are not always the best sources for local plant sizes and climatic requirements. Nurserymen are especially helpful in being certain that you have the 6' to 8' variety you are after. Some varieties of the same species look the same when they are young plants but after planting you discover that the mature plant does not grow over two feet tall.

Plant the plants, chosen for that one location in your garden ... on paper first. Use a scale drawing. An average residential lot, using a scale of 1" to 8' will fit an 18" x 24" page. Don't be afraid to group plants so that they overlap, if you want to achieve the "masses of foliage" look. Plants can overlap as much as 2/3 of their diameter. Lay out the plants (at 2/3 their natural size) as circles. Try to select varieties of dark green color, medium texture (leaf size) and of dense growth patterns for your backdrop. These background plants should not be too bold as this will detract from your foreground plants.

Selection of foreground plants may reflect personal choices. Here would be the place to put your own personality into your garden. The foreground plants may be more bold and eye-catching. They should be strong and stand out in front of the dark green neutral background.

Reliability will come from not forcing an exotic specie into an unnatural environment. Although you may have to sacrifice the selection of exotic species in this type of natural selection, it will pay large dividends in reliability, low maintenance and success.

Try using this method and you will be using the basic framework that most landscape architects and some landscape designers employ regularly to create successful low maintenance gardens.

Next month: selection of foreground plants.

Editor's note: Bob Clay is a graduate of Cal Poly at San Luis Obispo. He majored in ornamental horticulture and also has a degree in fruit production. Mr. Clay is a licensed Landscape Architect and teaches nursery landscape technology at Mesa Evening College. Any questions from readers will be answered in this column as space permits.

GOURMET FOOD

by Jeanne Coberly

Sugar and spice and everything nice is part of an old childhood chant. This month food fans will be delighted to have the recipe for Jeanne Coberly's Shrimp and Rice and everything nice, ... a variation on that chant. Jeanne has added ham for a surprising and happy flavor foil. It is sure to find its way to your permanent recipe files.

SHRIMP AND RICE

2 cups uncooked rice
½ cup bacon drippings
2 cloves garlic, minced
1 large onion, thinly sliced
1 green pepper, cut in thin strips
1 cup diced tomatoes
1 cup diced smoked ham
2 cups cooked shrimp
1 small sprig thyme
1 small piece of bay leaf
Salt, pepper, and cayenne

Wash rice, drain and dry well. Brown it slowly in the bacon drippings, stirring frequently. Add garlic and onion and cook a few minutes longer. Then add the remaining ingredients, with seasonings to taste. Cover and let simmer slowly about 45 minutes. If it should cook dry, add a little hot water. One or two cups cooked fresh peas may be added just before serving.

PEPPER SALAD

3 green peppers
1 lb. cottage cheese
1 medium onion, finely chopped
1 clove garlic, finely chopped
4 radishes, thinly sliced
¾ cup chopped parsley
Chopped fresh dill
Salt and pepper

Clean and seed peppers. Blend together with fork the cottage cheese, onion, garlic, radishes, and parsley. Add dill, salt and pepper to taste and stuff the peppers with this mixture, pressing it in as tightly as possible. Refrigerate for three or four hours. Slice the peppers in ½ inch slices. Arrange them on a bed of watercress alternately with slices of tomato. Serve with French dressing and lots of freshly ground pepper.

ITALIAN SAUSAGE AND POTATO CASSEROLE

3 lbs. russet potatoes
2½ cups warm milk, approx.
4 tbsps. butter, approx.
6 tbsps. grated Parmesan cheese
Salt and pepper
Nutmeg
6 Italian sausages

Peel potatoes, cut and boil as for regular mashed potatoes. Put them through a ricer when done. Add milk,

butter, and salt, pepper and nutmeg to taste. Beat until fluffy. Skin the sausages. Crumble the meat and saute it over low heat, without any additional fat, for about 15 minutes. Mix into the mashed potatoes. Butter a deep baking dish and fill it with the mixture. Cover it with the Parmesan cheese. Bake in a 375° oven for about 25 minutes, or until a golden brown crust has formed on top.

SPINACH SOUFFLE

3 tbsps. butter
3 tbsps. flour
1 cup milk
½ tsp. salt
4 egg yolks
1½ cups chopped cooked spinach
5 egg whites

Melt butter in upper part of a double boiler. Blend in the flour, stirring constantly. Add the milk and continue stirring until the mixture thickens. Season with the salt. When mixture has cooled slightly, add the egg yolks, which have been well beaten. Blend well, and then fold in the spinach. Beat egg whites until stiff and gently fold into the spinach mixture. Place in a well buttered 2 quart baking dish. Bake in a 375° oven for 35 to 45 minutes, or until souffle is lightly browned and well puffed. Serve at once — good with sauteed mushrooms.

FUDGE STICKS

5 squares unsweetened chocolate
¼ pound butter
½ cup vegetable shortening
4 eggs
¼ tsp. salt
2 cups sugar
1 tbsps. vanilla
1 cup sifted flour
1 cup finely chopped walnuts

Melt chocolate, butter, and shortening together over hot water. Mix thoroughly and let cool slightly. Beat eggs with salt until light in color. Add sugar gradually and beat until creamy. Add chocolate mixture and vanilla. Fold in well. Add flour all at once. Beat until smooth. Stir in half of the nuts. Butter an 8" x 16" x 1½" pan. In it spread the batter evenly. Sprinkle remaining nuts on top. Bake in a 325° oven for about 35 minutes. Cut into sticks while hot, then cool in pan.

ROW RESTAURANT

BAMBOO HOUSE RESTAURANT — Your host, Calvin Jeng, will personally greet you and escort you to your table in this delightful rendezvous-restaurant where you will be served gourmet Cantonese cuisine amidst a background of ancient Chinese art. Luncheon and dinner specialties are artfully prepared by a lady chef. Open every day except Sunday (Mother's Day the only exception). Ample parking facilities. Parties a specialty. Call Calvin Jeng at 232-5391. 422 Market Street, San Diego.

THE COFFEE MILL — In the heart of Encinitas. It's so nice to find a dining spot that doesn't seem to know what a can opener is! Every vegetable served at the Coffee Mill is prepared fresh, and served piping hot with melted butter. The desserts are delicious — wonderful pies, and home-made old-fashioned puddings. A "bread basket" accompanies every dinner. Very, very reasonable prices. Open from 6 a.m. to 8:30 p.m. seven days a week. For reservations call 753-3181 531 Highway 101, Encinitas.

LAURA'S ITALIAN RESTAURANT — offers you the very best in authentic Italian cuisine. Owned and operated by the Scardino family since 1941, the menu offers a delightful mouth watering array from Veal Scaloppini, Veal Parmigiana, Cannelloni al forno, Manicotti al forno to raviolis, baked lasagna and the very best pizza in north county. Italian lunches and dinners with beer or wine, of course. Food to go. Banquet room and private dining room. Modest prices. Laura says to you, "Come join our family, to serve you is our pleasure." BankAmericard & Master Charge accepted. Open Wed. thru Mon. 11:30 a.m. to 10 p.m. 915 S. Escondido Blvd., Escondido, 745-5261.

OAK TREE — offers especially good foods in an atmosphere of great charm. Indoor and outdoor dining, impeccable service and delightful house specialties — fragrant, crisp Bouncing Baby Popovers; Roast New York Strip, an aged, premium roast loin of beef sliced English style; Veal Cordon Bleu using Canadian Bacon and tangy Swiss cheese sauce, and their Breast of Chicken with a subtle cheese sauce is to write about! A variety of premium quality, aged steaks is offered, Sear-Charbroiled to your direction. Cocktails, of course, and the wine list is excellent and surprisingly varied. Modest prices, dinner reservations recommended. Open 11:30 a.m.-2 p.m., Mon. thru Fri. only, and 5:30-9 p.m. weekdays, 5:30-10 p.m. Fri. & Sat. Closed Sundays. 7811 Herschel Ave., La Jolla, 454-1315.

SAN LUIS REY COUNTRY CLUB & RESORT — an enchanting mood is created for you when dining in the restaurant or enjoying a cocktail in the lounge. Both command a magnificent view of the smooth green golf course, contrasted by the rugged beauty of the rolling hills. San Luis Rey Downs is just 11 miles east of Oceanside. Take Highway 395 to Camino Del Rey and turn west for 4 short miles. Dinner is served from 6:00 p.m. til 9:00 p.m. Monday through Thursday; on Friday and Saturday 6:00 p.m. through 10:30 p.m. Dancing Thursday through Sunday. Buffet every Sunday from 5:00 p.m. through 9:00 p.m. For reservations call: 758-0330.

RANCHO BERNARDO INN — in lovely Rancho Bernardo, overlooking the West Golf Course. Spanish decor, complete continental dining in the main dining room. **El Bizcocho** Tuesday through Sunday, dinner, lunch and breakfast. Special buffet on Sunday, brunch 11:00 a.m.-2:30 p.m., dinner buffet 5 p.m.-9 p.m. Dancing nightly except Monday, from 9 p.m. in **La Taberna Lounge**. And featuring a great new little restaurant, **The Cattle 'n Cask**. A warm, intimate atmosphere to enjoy delicious lobster, crab, steaks and other specialties. Open for lunch, dinner and cocktails daily from 10:30 a.m.-2:00 a.m. Dinner served up to 11 p.m. It's the perfect 19th hole oasis, located opposite the golf pro shop. Try it soon. For reservations in El Bizcocho, call 487-1611. No reservations needed in the Cattle 'n Cask. Located 5 minutes south of Escondido on Highway 395 (I-15 south).

NEMO'S COVE — Located in the Gazebo Courtyard of The Mercado in Rancho Bernardo, is dedicated to excellent food at reasonable prices. Our specialty, Seafood Supreme, heads a menu featuring the freshest fish filets, shrimp, scallops and chicken Kiev for those who desire a change of pace. Our luncheon menu features fish and chips using fresh filets and New England clam chowder. Open weekdays 11 a.m. to 8 p.m. and Friday thru Sunday 11 a.m. to 8:30 p.m.

THE SAN DIEGO OPERA

Proudly presents
the magnificent

BEVERLY SILLS

as

NORMA

Conducted by

**CHARLES
MACKERRAS**

Conceived & Directed by

**TITO
CAPOBIANCO**

with

Tatiana Troyanos

as Adalgisa

John Alexander as Pollione

Robert Hale as Orovoso



Scenes of pageantry and moments of ringing grandeur combine with great and noble music in Bellini's powerful tragedy.

JUNE 7 & 10
8:00 P.M.

JUNE 13 — 2:30 P.M.
JUNE 15 — 7:00 P.M.

**CIVIC THEATRE
BOX OFFICE**

236-6510

Good seats
in some areas

Tickets: \$14.50,
\$13, \$11.50, \$10,
\$8.50, \$6.50, \$4.75

For mail orders include 25c handling
and self-addressed stamped envelope.

THE WINE DRINKER

By Tom Gable

If California winemakers were to abandon their preoccupation with producing complete lines of wine and concentrate instead on a single variety, the choice would be Chardonnay.

Granted, California winemakers do well with Cabernet Sauvignon, the predominant wine grape of the Bordeaux area of France. The problem is that the varietal name has such appeal, prices don't always reflect quality. In 1972, for example, less than five California winemakers produced a Cabernet worthy of the variety, yet the other hundred or so who issued a product under that name maintained prices charged for the 1971 vintage, which wasn't as bad.

With Cabernet, clever marketers also issue the wine in increments. If the first increment sells well and garners high scores at prestigious tastings, prices are raised for the next increment, and so on. This is possible, to a certain extent, because Cabernet can be held around 20 or 30 years.

Chardonnay, on the other hand, hasn't gained the popularity of Cabernet in California, despite the fact that winemakers do a better overall job with it, even in poorer vintages. Chardonnay is the great white wine grape of Burgundy and Chablis in France and if you ask French wine experts which California wine consistently shows the best they almost always answer "Chardonnay".

A good California Chardonnay, and there are a dozen a year or more, can be elegant, rich and incredibly deep in flavor. The "biggest", or those with the most body, usually have almost buttery undertones. Some wine tasters call it an "oily" characteristic because the wine achieves incredible viscosity. It can range from pale straw to golden in color. The great wines of Chablis in France usually have a brilliant green tinge to their otherwise pale gold color.

Since Chardonnay hasn't gained the popularity of Cabernet and doesn't go through incremental increases, you can still find incredible wines for \$5.00, \$6.00 and \$7.50. Some of these wines

can be compared to the best of other countries. The comparison becomes most favorable when a few of the wines from the other countries, such as France, retail for \$12.00 a bottle and up.

In California, the great names in Chardonnay are usually Heitz, Sterling, Chalone, Spring Mountain, David Bruce, Freemark Abbey and Mayacamas in the higher-priced range, and Wente, Parducci, Beaulieu and Charles Krug in the medium-priced range. The styles range from the oily richness of the wines of Heitz and David Bruce, to the crispier, fruity, but less complex Wente Chardonnay.

The 1973 David Bruce Late Harvest Chardonnay (\$10.00) is a BIG wine that will last for many years. Other full-bodied, deeper Chardonnays are the 1972 Mayacamas from Napa Valley (\$7.50); Chalone (\$9.00); and the 1973 Heitz (\$7.50). If you enjoy the background aroma and taste of French oak barrels along with your Chardonnay, these are for you.

A shade lighter in their oakiness, which comes from aging in small, new oak barrels, are the 1973 Freemark Abbey (\$6.50); the 1973 Spring Mountain (\$7.50); the 1974 Burgess, Winery Lake (\$6.50); and the 1973 Sterling (\$6.00). There still may be some of the 1972 Freemark Abbey Chardonnay sitting around at your favorite merchant. It sells for \$6.00 or \$6.50 and is ideal for drinking now.

The crispier, fruitier wines would include the 1973 Stoney Hill (\$7.00); 1974 Harbor (\$5.75); 1973 Beaulieu Vineyard (\$4.50); the 1974 Krug (\$4.50); and the 1973 Parducci Cellar-master Chardonnay (\$5.75). The Wente, at \$3.75, is lighter in style but a sound dollar value.

Chardonnay is one of the few white table wines that improves with age, up to a point. Some of the top California Chardonnays have shown remarkable quality at 10 years of age. They are a great complement to fine food and go best with seafood, shellfish, cheeses and dishes with light creamy cheese sauces. Chill slightly before serving.

RANCHO SANTA FE

GAZZETTE

EDITED BY LOUELLA LIVERWURST

NEW SYMPHONY ASSOCIATION FORMED

The first meeting of the newly-formed Community Friends of the San Diego Symphony was held on Sunday, April 11, at the home of Mrs. H. Chandlee Turner, Jr. on Lago Lindo. Dr. Carleton Vail and Mrs. Turner, both of whom serve on the Board of Trustees of the Symphony were co-hosts.

The Symphony is appreciated in this area, and the attendance is good, but the largest part of the support has come from The Women's Auxiliary, one of twelve in this county. It was felt that men needed to assume an active role, as there are just as many men who are enthusiastic about good music, and their support and interest would be a great addition.

Present were: Mr. and Mrs. Arleigh Anderson, Mrs. Lenore Bates, Miss Ruth Bradley, Mrs. William E. Cunningham, Mrs. Donald Dunwoody, Mr. and Mrs. Bernard W. Eades, Mr. and Mrs. Joseph Fuller, Mr. and Mrs. William Gage, Mr. and Mrs. Edwin Hunter, Mrs. Edward Havens, Mr. and Mrs. James Jarnagin, Mr. and Mrs. Michel Puyans, Mrs. Desia Ritson, Mr. and Mrs. W. S. Rosenberger, Mrs. Henry Sanger, Mr. and Mrs. Donald Sutherland, Mrs. H. C. Turner, Jr., Dr. and Mrs. Carleton Vail, Mrs. Karl A. Weber, Mrs. Marcelle Witten, Dr. and Mrs. William C. Winter and Mr. and Mrs. Frank Weston.

VIENNESE BALL SET

The 27th annual Viennese Ball will be held at Hotel Del Coronado May 22. The annual affair benefits the San Diego Symphony.

The evening begins with cocktails at 7:00 p.m. and dinner will be served at 8:15. Patrons will dance to the music of Freddy Martin.

Cost per couple is \$100. For reservations contact Mrs. Walter Carpenter, 2242 Alexander Dr., Escondido 92025. □



Everyone's favorite reporter! Pictured above is our own Louella Liverwurst who obviously is on the hunt for Rancho Santa Fe news. Call her if you have any newsworthy item for the June issue of North County Living Magazine.

PICKING SELECTED



Mark E. Picking

A phone call from Congressman Clair Burgener brought the happy news at 6:30 a.m. on April 13. Mark E. Picking of Rancho Santa Fe (Torrey Pines High) received his appointment to the United States Air Force Academy at Colorado. The number of students seeking appointments to the AF Academy this year is the highest in the school's 22-year history. □

DOMINO CHAMPS!



World Domino Champions, R. Hastings Garland (L) and Louis C. Whitson of Barney and Barney general insurance agency display the unique trophy won in recent competition in San Francisco, along with a sample of their winning domino technique. □

BOBERTZ APPOINTED



Charles M. Bobertz receives congratulations from assistant manager Rea Mowery following his appointment as manager of the Rancho Santa Fe Association. Looking on is Mrs. Bobertz. Bobertz will take over the post June 14. (News Press photo)

GAZETTE

RSF YOUTH HORSE SHOW

Plans are underway once again for the 3rd annual Rancho Santa Fe Youth Horse Show, to be held at the Rancho Riding Club on August 20, 21, 22. The committee consists of dedicated Rancho Santa Fe residents. They are:

Youth Chairman, Ty Miller; Riding Club Chairman, Mrs. Brock Cowan; Publicity, Mrs. R. K. Colbourne; Trophies, Mrs. Peter Fletcher and Mrs. Don Sherman; Sponsors, Jeff Van Liew; Program, Mrs. T. C. Young; Pre Horse Show Party, Mrs. R. C. Browne and Mrs. J. Van Liew; Hospitality, Mr. and Mrs. Paul Fletcher; Youth Workers, Mrs. Doug Allred; Raffle, Mrs. Steve Mc Williams; Sweet Booth, Mrs. Harry Heid; Golf, Dr. and Mrs. J. R. Nelson; Arts, Mrs. John Edington; Breakfast, Dr. and Mrs. G. Goudy and Mr. and Mrs. G. Nordin; Chef, Brock Cowan; Popcorn, Mrs. Terry Gillies; Boxes, Mrs. Bruce Cavanaugh; Coke Booth, Mrs. Thomas Flanagan, and Treasurer, Mrs. Al Skagerberg. □

MARTINEZ-CARPENTER NUPTIALS ANNOUNCED



Jeanette Carpenter and John Martinez.

John Martinez of Solana Beach and Jeanette Carpenter of Encinitas announce the plans of their forthcoming marriage, to take place June 12 at St. Andrew's Episcopal Church in Encinitas. The Rev. Ralph Haynes will officiate.

Jeanette, the daughter of Mr. and Mrs. David L. Carpenter, is a graduate of San Luis Rey Academy. Her fiancé, the son of Mr. and Mrs. Refugio Martinez, is a graduate of San Dieguito High School and is employed by the City of Del Mar.

They will make their first home in San Marcos. □

66 / MAY 1976

50 YEAR SWINGER

The Women's Golf Club of Rancho Santa Fe recently honored one of their most popular members, **Ida Mae Moore**, on the celebration of her being a Ranch Resident (and great golfer) for half a century! A gourmet luncheon was served after an Ida Mae Moore Golf Tournament and hosts of friends gathered at the home of Mrs. John Barclay on Las Planideras. □



A specially decorated cake for the guest of honor!



Hostess Edith Barclay.

VISTA CENTER GROUND-BREAKING

Ground-breaking ceremonies were held recently for the long-awaited Vista Center Addition.

Lee Taylor, chairman of the San Diego County Board of Supervisors, and Frank Meyer, former mayor of the City of Vista, were the guest speakers, introduced by David K. Speer, County chief administrative officer.

Construction of the facility, which was approved by the County Board of Supervisors Feb. 10, 1976, will cost some \$14,880,000 and be built by M. H. Golden Construction Company on a 25-acre site located at 325 Melrose Drive in Vista.

The facility will be a one-story, air conditioned, reinforced concrete structure of 222,208 square feet.

The addition will house a jail with a capacity for 139 male inmates, eight juveniles and 18 female inmates; a sheriff's substation; two court wings, designed to eventually hold 14 courts (seven Superior and seven Municipal) and two office wings housing personnel from six County offices.

Adjacent to the facility will be a new automotive service center of 5,058 square feet for servicing County vehicles operating in North County areas.

Public parking with a capacity for



Ted Marioncelli, administrative aide; ex-Mayor Frank Meyer of Vista, Leroy Taylor, and Dave Speer, County Administrative Officer as they prepare to break ground for the new Vista Center.

706 cars and employee parking for 163 cars will also be included with the facility.

The addition is being built by the Vista-County of San Diego Building Authority and will be leased to the County of San Diego.

Architects for the project are Hatch, Heimerdinger and Grandgirard, Inc. of San Diego.

The project is expected to be completed in July of 1978. □

GAZETTE

BARRIO LUNCH

Kenneth W. Keegan, president-owner of the San Diego Jaws, was the guest speaker at the "An Hour in the Barrio" luncheon at noon on April 2 at the Chicano Community Center, 1809 National Avenue.

The Luncheon, one of a series presented by the Mexican and American Foundation, honored civic and cultural leaders.

Carol A. Smathers, Rancho Santa Fe, co-producer of this year's An Evening with the Stars, a benefit sponsored by the foundation, was recognized as Woman of Distinction and Verne W. Thompson, an industrial consultant, was honored as Man of Distinction.

Also honored were Mario Acevedo Torero, of the Acevedo International Art Gallery, and Sammy King, a ventriloquist who appeared in last year's An Evening with the Stars production.

Francisco King, who also participated in last year's An Evening with the Stars, was master of ceremonies. □



Carol A. Smathers



Kenneth W. Keegan

SCIENCE FAIR

The recent Science Fair held by the Rancho Santa Fe School produced 41 exhibits, which were judged by Messieurs Badger, Bayly, Colby, Massie, Randol and Tolley.

Winners of the sweepstakes and trophies were Ann Middleton, Sherri Broome, Paula Nelson, Chris Dee, Diane & Cindy Jenkins. David Olsen also received a special trophy because of the high quality of his project.

Rancho Santa Fe Rotary Club provided ribbons and trophies for this valuable learning program. □



Mr. James Tolley listens to students' explanation of their project.



Mr. Del Colby discusses project with students.



Mr. Chuck Badger judges.



Mrs. Russ Zasio, one of Rancho Santa Fe's most attractive young matrons, first took up riding in Holland. Shelly has been showing Arabian horses for many years. The April La Jolla Farms show was her jumping debut.

HORSE SHOW BUFFS

Rancho East is always well-represented at the local and regional horse-shows. Our roving reporter caught two early morning participants. □



Mary Elizabeth Giffin won a second, two sevenths, and an eighth on "Without A Doubt" owned by Rancho East.

GAZETTE

ANNUAL MEETING HELD AT INN

Rancho Santa Fe Savings & Loan held their third Annual Meeting last month at the Rancho Santa Fe Inn. Following the business get-together the group gathered by the pool for cocktails and hors d'oeuvres.



Judge Nix



Left to right: Mr. Ted Loretz, Aiko Kamei, Mrs. Loretz.



Tom Lay Fred Teckemeyer



Left to right: Jean Clark, D. W. Ausbrooks and Gail Schler.



Sue Colbourne with two junior stockholders: son Kip and daughter Nancy.



Left to right: Kay Wasser and Janet Falconer.

MISS SAN DIEGUITO CROWNED

"April Showers bring May flowers," and beauty blossoms everywhere. You'd know if you were there. Where? At the Miss San Dieguito contest, held Sunday, April 4, at the Winners Circle Lodge. Fifteen local beauties competed for the title to represent the San Dieguito area. They were Terri Barker, Solana Beach; Annette Bruske, Del Mar; Darlene Bulen, Cardiff; Stacy Campana, Solana Beach; Kathe Clark, Solana Beach; Pamela Eshelman, Del Mar; Sherri Gale, Encinitas; Julie Huber, Solana Beach; Cherise Jones, Encinitas; Karen Kampf, Rancho Santa Fe; Lynn Lafferty, Del Mar; Gail Madruga, Del Mar; Leslie Sterkel, Rancho Santa Fe; Mie Lyn Tsuchimoto, Encinitas, and Ann Schoell, Del Mar.

Miss Kim Hano, who is the 1975 Miss San Dieguito and who also holds the title of Miss North County, was present to crown the new queen, Pamela Eshelman. First runner-up was Karen Kampf. Second and third runners-up were Annette Bruske and Darlene Bulen respectively. Prior to the contest, the girls met for several rehearsals and other affairs, after which the girls themselves voted on a Miss Congeniality which was presented to Sherri Gale.

Doris Boyar, who is the county-wide director/producer for the Fairest of the Fair pageant and also head of the wives' events for the San Diego Andy Williams Open and director/producer for the Miss Baja-California International contest, acted as emcee for the event.



Pamela Sue Eshelman of Del Mar

SECOND ANNUAL

RSF YOUTH GOLF BENEFIT

WHY? — To fund a wide variety of youth and adult activities at the Rancho Santa Fe Youth Center, and to reduce the debt on the Holcomb Memorial Youth Center — even if you can't make this enjoyable event, your contribution will be appreciated by the youth.

WHEN? — **Friday, May 21, 1976**
Starting 11:00 a.m. with a Bicentennial cannon salute.

WHAT? — Exciting golf, a challenging course, excellent food, refreshments, cocktails, awards, and friendly golfers.

WHERE? — The beautiful Rancho Santa Fe Golf Course

SPECIAL EVENT

Prior to Tournament — Pro Tommy Jacobs' Golf Clinic starts at 10:00 a.m.

Entry Fee \$75.00 — Golf carts provided — Tax deductible
Donations received
Please make checks payable to: Rancho Santa Fe Youth, Inc.

DETACH HERE

SEND RESERVATION NOW TO:
Mr. Terry Gillies, Box 497, Rancho Santa Fe, Calif. 92067. Phone 756-2867.

SEND RESERVATION NOW TO:
Mr. Terry Gillies, Box 497, Rancho Santa Fe, Calif. 92067. Phone 756-2867.

NAME: _____

ADDRESS: _____

PHONE: _____ HANDICAP: _____

NO HANDICAP FLIGHT INCLUDED

Foursomes arranged by Toumey Committee unless special requests are made in advance.

OTHER FOURSOME MEMBERS:

GAZETTE



Dori and Craig Starkey



Jim and Peggy O'Driscoll



Judy and Dick Arendee. Judy is President of Las Duenas.



Chuck Charman and Kay Anderson



The O. G. Sansomes (center) with out-of-town guests. Mr. and Mrs. Howard Nochunson. Mr. Nochunson is a carpet manufacturer in Atlanta, Georgia.



Dick and Sue Colbourne



Susan and George Thomas



Dr. D. L. Secrist and Tom Flanagan



Left to right: Ann and Terry Footer; Gloria and Bob Bohrer.
70 / MAY 1976



Attorney Roger Woolley and Dr. Joseph Capozzi



Will and Carol Magoffin

LAS DUENAS GALA

The annual Las Duenas Mariposa Ball, held last month at the Rancho Santa Fe Garden Club, was its usual overwhelming success. Cocktails preceded a gourmet sit-down dinner (Carriage Trade catered) followed by door prizes and dancing until the small hours. □



Carol and Don Looper with Pat Driver



Bob and Donna Holcombe



Phil and Bonnie Colbourne, Bonnie was chairman of the 1976 Mariposa Ball.

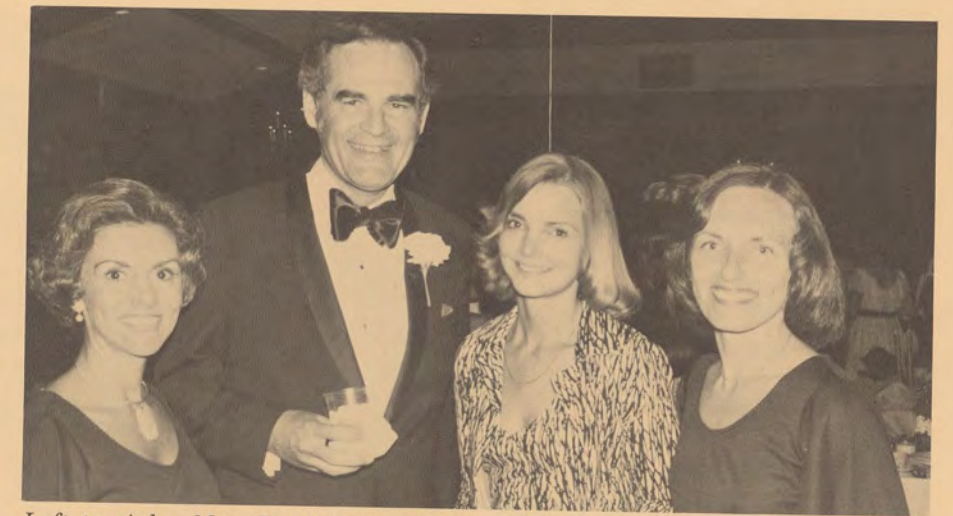

Left to right: Mrs. Paul Ecke, Jr.; Dr. Marc Cathey, Pres. of the American Horticultural Society; Mrs. John Feighner and Mrs. Thomas Flanagan.



Linda Charman, Ludlow and Carol Keeney



Bette Cunningham and Maggi Spraggon



Sheila Giacomini and Jim Russell



Left to right: The Keith Lindleys and the E R Harringtons.



Georg'Ann Fletcher



Peter Fletcher



Bob Shockney

THE
VILLAGE CHURCH
of Rancho Santa Fe
Community Presbyterian

Rev. DONALD R. CAUGHEY,
Minister

JAMES P. FREDA, JR.
Assistant

Sunday Worship: Church School:
10:00 a.m. 10:00 a.m.

having trouble
getting it together?

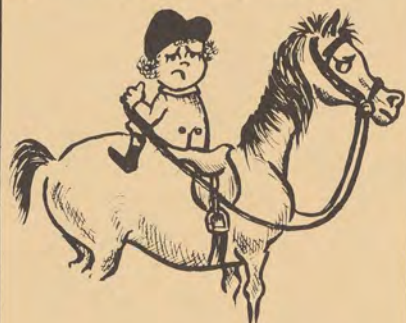

Equestrian Training
for Hunters & Jumpers

LESLEE BAREN

Located at
RANCHO CARLSBAD
EQUESTRIAN CENTER

2820 Sunny Creek Road
Carlsbad, California
(Just off El Camino Real)

DAY: 729-2212
EVE: 729-9039

The symbol of friendship
around the world



May I call on you?
Jean Louise Seaton
753-8507

GAZETTE

COUNTRY FRIENDS Here, There and Over Yonder

by Louise M. Warren

If you happen to be a push-over for sunshine, art and history (and who isn't?) can you possibly conceive of a perfect blend of all three? Well believe it or not the Country Friends' Over Yonder Shop has all three blended to sheer perfection in a set of four elegant stained glass windows. Designed and created in 1963 by Richard G. Chase, a master of this ancient art form, the beautiful panels originally belonged to C. Arnholt Smith. Mr. Chase designed them on assignment for the windows in Mr. Smith's office at the United States National Bank.

Stained glass is, historically, a very early craft. It is recorded that during the re-building of the Rheims Cathedral in 988, pictorial glass windows were installed. However, the earliest examples actually extant date from the eleventh century. The Country Friends, alas, do not own any eleventh century work. Most of it, unfortunately, has long since been shattered to oblivion.

However, these twentieth Century pieces, now on display at the Country Friends' shop, are more durable than the early creations. Chase used more modern techniques than the ancient glass workers, ensuring less fragile and more enduring art.

These incredible Chase masterpieces pictorially depict early dramatic history of the San Diego area.

One has a beautifully designed and executed figure of a pioneer, probably Cabrillo, meeting the Indians. Two others show later San Diego-area pioneers. And finally, my own favorite, a group of beautiful Spanish dancers in authentic costumes of the period.

Blue, green and gold tones predominate in these exquisite wonders of design and fulfillment. These tinted glass treasures constitute the bargain of the year. The entire set is priced lower than the original cost charged by the artist for each individual panel.

They can be used as large window panes, letting the sunshine generate the incredible glow of the colors, or they can be hung on panelled walls with lights behind them to create a similar effect. They would greatly enhance an office or a home or, hopefully, a public

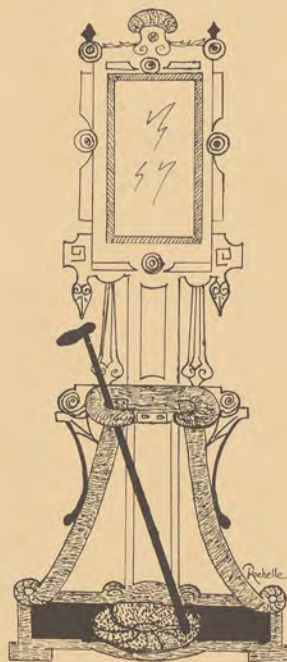

The intriguing sketch accompanying this article was drawn by talented Ranchoite and Country Friend Rochelle Green.

building or restaurant where everyone could enjoy them. I would love having them forever in my own living room, but, alas! my walls aren't tall enough to accommodate them. I said to my husband, "Let's raise the roof." But he said he was too tired. So, these choice items are still available for some more fortunate purchaser.

I am still a strolling window gazer. For others similarly addicted, there is a new and rewarding arrangement in the window facing on Avenida de Acacias. Beautiful turn-of-the-century American pieces are featured. An old walnut hall tree, originally from St. Louis is dated 1904. A pair of carved oak chairs are typical of the 1900 American designers. The chairs are enhanced by upholstered seats, done in colorful velvet patch-work. Adding to the charm of the setting are a pair of Tiffany-style hanging lamps and a unique piece of enchanting sculpture. It is a 1900 recreation of either the Greek Goddess Doris or Ino or possibly the Roman Goddess Salacia. All three were goddesses of the sea and the "help-mates" of fishermen. This particular goddess even has a fishing line and the day's catch. This is a perfect gift for a committed rod and reel agent.

Come on Over Yonder and see! □

ACCOLADES

It was one of the greatest performances we've ever seen. "Fiddler on the Roof," produced by the Rancho Santa Fe Drama Class of 1976, was superb — with special mention going to the leading man, Tim Holcombe, whose portrayal of Tevye was nothing short of sensational. Tori Webb as Golde, his wife, was excellent — with 4-star ratings going to the five daughters (Carol Damon, Sally Booth, Betsy Shoup, Liz Eppler and Janice Heid). Gena Arcaro as the matchmaker was extremely adept while Steve Lindley as Motel Kamsol, the tailor, deserves plaudits. In fact, the entire cast not only knew their parts well, they showed great stage presence and projected beautifully. They gave a "total performance" that brings great credit to the shoulders of Director Bill Spivey; music, choreography, make-up and pianist, Terri Castle, and drama coach, Gloria Booth. □



Tim Holcombe as Tevye brought down the house! Not once, but many times during the evening!

FASHION SHOW CHAIRMAN



Mrs. Frank R. Warren

Mrs. James D. Brown, president of The Country Friends, has announced that Mrs. Frank R. Warren of Rancho Santa Fe will again serve as chairman for the "Appearance of Autumn" Fashion Show to be held Sept. 21. Mrs. Paul Ecke, Jr., will again serve as co-chairman.

The show, which is sold out annually, will be held on the lawns of The Inn at Rancho Santa Fe, where designer fashions from John Hogan and jewelry from J. Jessop & Sons will be shown. Each year a guest designer is invited to show his new fall and winter collection. Last year, Michael Novarese was featured.

Mrs. Warren is first vice president of The Country Friends. She is also a member of the Beach and Country Guild of Cerebral Palsy, and Trustee of the Children's Hospital, and WAIF.

Mrs. Warren and her husband, chairman of the board of Rancho Santa Fe Savings & Loan, have five children. □

SYMPHONY AUXILIARY MEETS

The home of Mrs. Edwin J. Hunter was the setting April 12 of the spring meeting of the Rancho Santa Fe Auxiliary of the Women's Committee of the San Diego Symphony Orchestra Association. Mrs. H. Chandlee Turner, auxiliary chairman, conducted the 2 p.m. meeting at which the slate of officers for 1976-77 was presented. They are Mrs. H. Chandlee Turner, chairman; Mrs. William P. Gage, vice-chairman; Mrs. Clair M. Alderson, treasurer; Mrs. Lenore Bates, corresponding secretary, and Miss Ruth V. Bradley, recording secretary.

The honored guest who presented the program was Miss Gail Dieterichs. Miss Dieterichs substituted on very short notice for an ailing Michael Detherage, cellist. Miss Dieterichs plays the harp with the San Diego

Symphony, as well as the La Jolla Symphonia and the La Jolla Chamber Orchestra. She is a graduate of the Eastman School of Music and has played with orchestras across the United States before settling here. She teaches piano and harp at the Bishop's School. As well as teaching and performing with the orchestras here, Miss Dieterichs is a recitalist. For the program she presented at the meeting, Miss Dieterichs played the 2nd movement of the *Concerto in C Minor* by Françoise Boieldieu, *Whirlwind* by Carlos Salzedo, *Moonlight on the Pool* by Marcel Tournier and *Fire Dance* by David Watkins. In addition to the delightful program, she gave the auxiliary fascinating information about the harp, harp music and harpists during a question and answer period.

instant passport photos

- In full color
- All official sizes
- Professional quality
- By appointment

House of Portraits

1430 Camino Del Mar
DEL MAR • 755-9347

del RANCHO POOLS

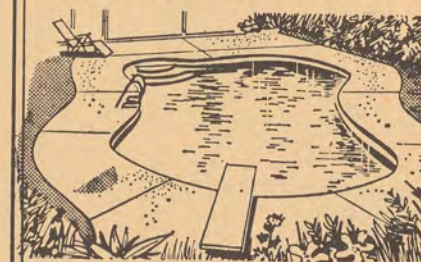

CUSTOM POOLS DESIGNED & BUILT

Complete Planning &
Estimating Service
Hi Chem
Repair & Maintenance



All contracts trust fund controlled
State licensed Distributors for some
of the leading pool companies
in swimming pool equipment & supplies.

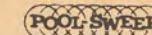

"Let your pool be as individual as your personality!"

753-6369

1163 First Street, Encinitas
Serving North County
State Contractors License 207129

GAZETTE

ACROSS

1. Kind of paper
4. Con
8. Voyaging
12. Single unit
13. Abel's brother
14. Frigid
15. Annoying action
17. Stratagem
18. Pare
19. Undo
21. Harmonious tone
23. Bounders
24. Sharpen a razor
25. House servant
29. The dry continent (Abbr.)
30. Ignites
31. Fish eggs
32. Grounds
34. Small lake
35. Aardvark's diet

36. Aphid
37. Things to be done
40. Batters
41. Tell of danger
42. Pilots
46. Qualified
47. Containers
48. Rodent
49. French River
50. Sharpness
51. Secret agent

DOWN

1. Male turkey
2. Blackbird
3. An answer
4. Throbbled
5. Symbol of hardness
6. Bind
7. Sets on fire
8. Over
9. French coins
10. Otherwise
11. Gulf in Arabia

16. Part of bird's bill
20. Poems
21. Fellow (Colloq.)
22. Appointed time
23. Fruit centers
25. Dislike
26. Men's pants
27. Space particles
28. Yield
30. Discover
33. Deportment
34. Splendor
36. Slip
37. Absent
38. Talks a lot (Colloq.)
39. Author Gardner
40. Encircle
43. Young goat
44. Smart blow
45. Pigpen

1	2	3		4	5	6	7		8	9	10	11
12				13					14			
15			16						17			
		18						19	20			
21	22					23						
24					25					26	27	28
29				30						31		
32			33							34		
			35							36		
37	38	39						40				
41					42	43					44	45
46					47						48	
49					50						51	

answer on page 76

THE GIRLS FROM TORREY PINES



Left to right: Jo Safford, Nora Marples, Dolly Adams, Sylvia Clifton, Lyla Turner, Barbara Iovin, Inez McDowell, Alice Boorse, Jean Swanson, Elaine Triolo and Sunny Thompson.

This wide-awake group of bright-eyed beautiful women were caught by our roving camera-man last month as they prepared to tee off for a fun day at Lomas Santa Fe Country Club. (The roses they are holding are all part of the game plan). The gals laughingly call themselves the "La Jolla Rejects" and are part of the Torrey Pines Golf Association.

THRIFT SHOP BENEFITS ANIMAL CARE



Spreading the word of unusual items found in the Animal Care Thrift Shop are the new co-chairpersons of the shop, Sonja Meyers of Rancho Santa Fe, left, and Sue Kobrin of Del Mar. An old-style intercom-telephone is one of the many items donated to the shop to be re-sold for benefit of the non-profit Animal Care Center in Rancho Santa Fe. The shop, at 2147 Newcastle, Cardiff. □

RANCHO RECORDS SET

Numerous Rancho athletes have established new track and field records already this season:

4th Graders

Mark Broome, 5.0 (35), 6.7 (50 yard dash), 13.1 (100), 43.6 (one lap race), 1:12.3 (440), 12'5" (running long jump) 75" (standing long jump); Steve Augusta, 6:07 (mile); Chris Bergen, 108' (softball throw); Shannon Biszantz, 85' (softball throw), 5'8" (standing long jump); and Greg Wiegand, 14.0 (70 yd. low hurdles).

5th Graders

Mike Lindley, 12'10" (running long jump); Mark Sansone, 6'3" (standing long jump); Scott Cunningham, 132' (softball throw); Mary Kies, 7.5 (50); Carol Warren, 53.0 (one lap race), 1:30.4 (440); Bridget Cantwell, 12.6 (low hurdles); Kathy Conway, 62' (softball throw), and Holly Iverson, 6'4" (standing long jump).

6th Graders

Danny O'Curran, 12.9 (low hurdles); Steve Lay, 125' (softball throw); Beth Dempsey, 101' (softball throw); Lisa Footer, 7'3" (standing long jump), and Beth Culver, 14.2 (low hurdles).

7th Graders

Barry Engelman, 6.4 (50), 16'10½" (running long jump), 7'8" (standing long jump); Kyle Jensen, 6:19 (mile), 32.0 (220), 11.5 (low hurdles); Scott Middleton, 138' (softball throw); Arlin Miller, 6.4 (50), 12.0 (100), 11.7 (low hurdles); Lory Driver, 43.8 (one lap race), 30.3 (220); Bonnie Southworth, 1:08.7 (440), 30.3 (220); Marianne Young, 15'9" (running long jump), 4'7" (high jump); Robin Rodgers, 6'6" (standing long jump), and Betsy Tompkins, 104' (softball throw).

8th Graders

David Allred, 6.3 (50), 36.4 (one lap race), 10.4 (low hurdles); Brad Southworth, 5:16 (mile), 16'2" (long jump); Barry Engelman, 29.2 (220); Tom Wiegand, 7'4" (standing long jump), 160' (softball throw); Cindy Jenkins, 44.1 (one lap); Diane Jenkins, 2:48.9 (half mile), 13.6 (low hurdles), 113' (softball throw), 6'6" (standing long jump), and Cindy Snyder, 34.8 (220).

Rancho East

"Home of the Miniature Horses"

HUNTERS • JUMPERS

BOARDING • TRAINING • LESSONS* • SALES

756-1713

Aliso Canyon Road, Rancho Santa Fe
Ginger Hill, Instructor; Peddie Happe, Trainer

*Beginner Advanced

For Those Who Want the Very Best

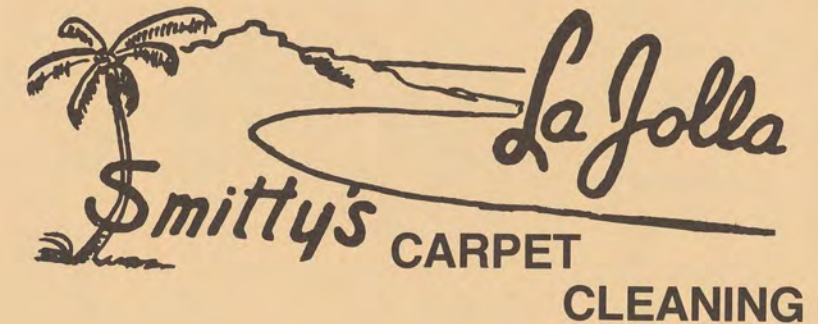

Member



CHARLES SMITH
Owner

30 Years
in La Jolla
and
Rancho
Santa Fe

459-3269

STEAM WAY METHOD

ALONG WITH CERTIFIED SHAMPOO

STEAM
WAY



THE
BETTER
WAY

GAZETTE

PATTI PAGE HONORARY CHAIRMAN

Miss Patti Page will serve as Honorary Chairman for the Children's Hospital Horse Show to be held June 5 and 6 at the Rancho Riding Club grounds. The show is co-sponsored by the San Dieguito Auxiliary to Children's Hospital and the Rancho Riding Club.

Miss Page's notable career spans singing with the "big bands," radio, television and movies.

She and her two children have made their home in Rancho Santa Fe for the last two years and are active in the horse world with their Tennessee Walkers.

Mrs. William S. Aylmer of the Rancho Riding Club and Mrs. Albert W. Himfar of the Children's Hospital Auxiliary are co-chairmen for the event. Serving with them will be Mrs. Gary Stevenson, secretary of entries, and Mrs. Harry W. Heid, treasurer. Mrs. C. Ray Harmon is in charge of boxes and Mrs. Robert J. Wallerstein will be handling class sponsors. Heading up the "Early Bird" hospitality will be Mrs. James R. Nelson, with Mrs. Amos Sommers as hospitality chairman for the officials. Mrs. A. Lynn Castle will take care of the officials' luncheons.

Some committee heads will repeat their jobs of last year. Mrs. M. Millar Ransom is again publicity chairman; Mrs. T.C. Young is acting as program chairman once more, and Mrs. David R. Somerville is repeating her duties as advertising chairman, with Mrs. Douglas Van Sicklen serving as her co-chairman.

In the "hunger and thirst" depart-

ment, Mrs. Preston M. Fleet is busy marshaling her forces of cooks.

Mrs. John E. Hamrick is in charge of the benefactors party, which will be held at the magnificent home of Mr. and Mrs. Alfred A. Gregory, which overlooks the fifth fairway of the Rancho Santa Fe Golf Course.

Husbands and wives serving as co-chairman are Mr. and Mrs. Bruce Cavanaugh, donations chairmen, and Mr. and Mrs. William A. Bray who will manage the Tack Traders Booth.

Mrs. Hugh Tietjen, as chairman of the "Horse Feathers" Boutique, has announced that there will be many new additions and innovations in this attractive gift booth this year.

In its thirtieth year, this show annually contributes over \$10,000 to the Children's Hospital in San Diego from the proceeds of the show. □



Patti Page

JUNIOR GOLF PROGRAM



Jim McConnell, Golf Professional, awarding prizes to the flight winners. From left to right: Eddie Hoskins, Mark Neel, Rick Brush, Ricky Cabo.

Rick Brush and Mark Neel were first and second flight winners respectively of the Rancho Santa Fe Golf Club Junior Golf Tournament held Saturday, March 13, ending this year's Winter Golf Program.

Fourteen girls and boys, ages nine to fifteen, participated in the program which included driving, chipping, and putting lessons from the club Professionals on Saturday afternoons as well as nine-hole practice play under the supervision of player Dads.

Ricky Cabo and John Warren came in second and third place of the first flight with Eddie Hoskins and Ricky Ptak receiving second and third places in the second flight. An awards party was held in the snack shop area following the tournament. □

THE BUSINESS CIRCUIT

HADLEY ORCHARDS OPENS IN CARLSBAD



Peggy and Paul Hadley - expanding a tradition of quality foods.

Hadley Orchards have opened their newest retail outlet on Palomar Airport Road at the I-5 off-ramp.

The Hadley name has enjoyed recognition for a quarter-century in merchandising sundried fruits, dates, cheeses, honey, nuts from around the world, vitamins, natural jams and jellies, candies, family-kitchen bakery goods and a wide variety of health foods. Recently, the Hadleys added their own wine selection, under Prestige Vineyards and El Camino labels. The wine-tasting room stocks most fine brands in addition to Hadley's own vintage.

Hadley's fame sprang from the original store in Cabazon, California, 16 miles west of Palm Springs on I-10. The growth of this Cabazon store, the largest of its kind in the world, has been the result of the large number of tourists who pour out of the Los Angeles area on vacations, week-ends, tours and farming business, most of whom find dates irresistible. The Hadleys found quality control in buying dates unsatisfactory and have acquired five date orchards of their own to assure plump and perfect fruit on their stands.

Carlsbad was chosen by the Hadleys for the new store site for two specific reasons. The enthusiasm and civic pride of the Carlsbad population are outstanding and the "best use" of property is obvious to any observer.

The Hadleys are pleased to be a part of Carlsbad and the North County. □

RSF S&L DEPOSITS UP 40%

A 40 percent increase in assets since January and payment of its first dividend has been announced by Rancho Santa Fe Savings and Loan Association.

According to the Association's Chairman, Frank R. Warren, assets of Rancho Santa Fe Savings and Loan climbed to more than \$22 million early in March, a \$6.5 million increase from the \$15.8 million reported in their year-end financial statement.

The Association's Board of Directors have also voted a 20c a share dividend payable on June 1, to shareholders of record as of May 15, 1976.

Rancho Santa Fe Savings and Loan Association opened in May, 1973 in Rancho Santa Fe, followed by a branch in Lomas Santa Fe in late 1974. A second branch was opened December, 1975 in La Jolla.

The Association held its annual stockholders' meeting April 6 at the Rancho Santa Fe Inn. □

JARVIS EXPANDS BUSINESS SERVICES

Mary Jane Jarvis, celebrating her second year in business, has expanded her services to include a limited answering service and the handling of business or personal affairs for individuals while they are out of town.

Personal Business Services consists of a personal and confidential service for clients, including dictation, letter writing, bill paying, medicare insurance forms, tax preparation and house sitting. References are available upon request.

The answering service is available daily from 7 a.m. to 7 p.m.



Mary Jane Jarvis

Mrs. Jarvis' staff of four employees, Philida Daniels, Linda Benish, Toni Wrenn and Ellen Cramer, also do typing, book-keeping and quarterly tax forms for many small businesses in Rancho Santa Fe. Mrs. Jarvis has been associated in business on the ranch since 1970 and is now a resident. Her offices are in the Culver Building. □

HISTORY REPEATS IN AARON BROS. COMMERCIALS

George Washington, Toulouse Lautrec and Napoleon are just three of the key characters included in a series of commercials produced for Aaron Bros. Art Mart by A & G Concepts of San Diego.

The commercials were shot on location at a new Aaron Bros. store in San Diego and will be shown throughout the west. In each, the character delivers a message on why Aaron Bros. would have been great to have around in the good old days of the invasion of Russia, the Follies Bergiere or the crossing of the Delaware.

Agency for Aaron Bros. is Lizardi & Witte, Inc., Los Angeles. A & G Concepts is one of the west's largest television production companies. □

WOMEN'S BANK NAMES AGENCY

The Women's Bank (in organization) has named The Gail Stoorza Company to handle its advertising and public relations.

The bank, located at 5353 Mission Center Road, opened last month.

Rita Mills McCoy, president of The Women's Bank, said The Gail Stoorza Co. was chosen from among a number of agencies seeking the account because of the firm's capabilities and understanding of the bank's objectives.

Carolyn Augustine, a communications consultant and freelance copywriter, will assist The Stoorza Company on the account.

Among clients of The Gail Stoorza Company are Avco Community Developers, Inc., The Vic Braden Tennis College, Sanford R. Goodkin Research Corp., Rancho Bernardo, Windemere, Quinn Robertson Design Associates and The Francis Family antique warehouse.

The Women's Bank of San Diego will be the first on the West Coast and the second in this country. The first opened in New York City in October, 1975.

The thirteen directors of the bank, which include two men and 11 women, have stated that the bank will offer its services to both women and men on a totally nondiscriminatory basis, and will encourage the economic participation and financial understanding of women on a parity with that available to men. □

SOUTHWEST BANK TO OPEN NEW OFFICE

Southwest Bank will relocate their Encinitas office at 1505 Encinitas Boulevard by mid-year, president Sid Fox announced today. The new location, just 50 yards east of their present address, is across from the Village Square Shopping Center.

The new 3,300 sq. ft. facility, designed by Richard Lumsden, A.I.A., features Spanish-style architecture and six drive-in lanes. The general contractor is Harold Andrews.

Southwest Bank, which began in 1961, has other offices in Carlsbad, Escondido, Fallbrook, Leucadia, Solana Beach, Vista and will open a new branch in Rancho Bernardo in early summer of this year. □

puzzle on page 74

T	A	R	A	N	T	I	A	S	E	A	
O	N	E	C	A	I	N	C	O	L	D	
M	I	S	C	H	I	E	F	R	U	S	E
	P	E	E	L	L	O	O	S	E	N	
C	H	O	R	D	C	A	D	S			
H	O	N	E	D	O	M	E	S	T	I	C
A	U	S	F	I	R	E	S	R	O	E	
P	R	E	M	I	S	E	S	P	O	N	D
	A	N	T	S	L	O	U	S	E		
A	G	E	N	D	A	R	A	M	S		
W	A	R	N	S	K	I	P	P	E	R	S
A	B	L	E	T	I	N	S	R	A	T	
Y	S	E	R	E	D	G	E	S	P	Y	

76 / MAY 1976



Mr. and Mrs. John Doe
P.O. Box 1326
Rancho Santa Fe
California 92067

TO: NORTH COUNTY LIVING
P.O. DRAWER Q
RANCHO SANTA FE, CA 92067

Please send me _____ set(s)
of 1000 Gold Foil Labels to

NAME _____
(26 character maximum)

ADDRESS _____

1000 EXCLUSIVE
"North County Design"
PRESS-ON LABELS
IN HANDSOME GOLD FOIL
\$10⁰⁰ PLUS 6% TAX

clip and mail

ENCINITAS GLASS CO.

ALL TYPES GLASS REPLACEMENT
 AUTO - HOME - STORE FRONTS -
 MIRRORS - TABLE TOPS
 CUSTOM PICTURE FRAMING
 and ART SUPPLIES
 Phone 753-6361
 687 Second St., Encinitas
 CA 92024

**Rancho Santa Fe
 DISPOSAL
 COMPANY**
753-4157
 or
753-7378
**TRASH PICKUP
 SERVICE...**

ASHLEY'S

**Rancho Santa Fe
 MARKET**
 "In The Village"
 756-1433

Antique Jewelry & Glass
 China, Furniture, Etc.

ROSIES
 Rancho Santa Fe

756-2659
 OPEN DAILY 9-4

ROSE RANSON

BUYING & SELLING
 ALL TYPES OF ANTIQUES

Mexican Cuisine - Cocktails

**ROSENDO'S
 HIDEAWAY**

Carmel Valley Road, Del Mar

755-3223 For Reservations

We are closed Monday

INVESTMENT COUNSELOR NAMED

Ralph Barnes has been appointed investment counselor for the newly-opened San Diego branch office of Newport Equity Funds, Inc., it has been announced by Lawrence A. Levinson, president of the mortgage brokerage firm.

Barnes joins Newport Equity Funds after two years in the San Diego office of Certified Plans, Inc., as a specialist in pension and profit sharing plans.



Ralph Barnes

The new office at 480 Camino del Rio South in San Diego is the first branch operation for Newport Equity Funds, a four-year-old firm specializing in investment trust deeds.

In 1975, the Newport Beach-based company tripled its dollar volume over calendar 1974.

PSA LOWERS FARES

Pacific Southwest Airlines (PSA) announced a lower fare for passengers traveling between San Diego and San Jose or Sacramento.

PSA has filed new tariffs which, by the California Public Utilities Commission rules, cannot take effect before a 30-day wait. The San Diego/Sacramento fare was lowered from \$35 to \$31.75 and the San Diego/San Jose fare was lowered from \$32 to \$31.50.

The Public Utilities Commission just authorized Air California a nine and one half per cent increase in its fares in the above two markets to the same amounts requested by PSA in its new tariff filing. In the same decision, the Commission authorized Air California to raise its Orange County/San Francisco Bay Area fares to \$28.75 and its Orange County/Sacramento fares to \$29.95. PSA serves Sacramento and the San Francisco Bay Area from Long Beach, Ontario, Burbank and Los Angeles at significantly lower fares. For example, PSA's Los Angeles/San Francisco Bay Area fares are \$25.50 and its Los Angeles/Sacramento fare is \$26.50 □

KPBS-FM WINS NPR AWARD

KPBS-FM has received the prestigious Corporation for Public Broadcasting 1976 Local Program Award for Excellence in News and Public Affairs at an Awards Luncheon in Washington, D.C. during the NPR Conference.

The award was given KPBS-FM for its special public hearing on American tuna fishing problems. KPBS-FM Program Director Tom McManus received the award on behalf of producer Ken Kramer and Technical Director Mike Stark. Said McManus, "the award is in recognition of the direction our station is headed — for immediate coverage of important local events and issues." □

VOLUME SOLAR PANEL PRODUCTION UNDERWAY

The Sunwater Company, Southern California's largest manufacturer of solar energy products, reports a successful entry into volume production of solar collector panels. According to Marketing Vice President Stewart Williams, a production rate of 2,000 square feet per day in solar collector panels will be achieved in the second quarter.

Williams said, "The company's total manufacturing inventory, which includes a complete line of swimming pool, domestic hot water and space heating flat plate collectors, plus solar water distillation units and solid state differential controls, will give the Sunwater Company and its licensees a distinct market advantage over its competition. Our goal is to meet growing public demands with quality products at lowest competitive prices."

Founded in 1958 by Horace McCracken, Sunwater is the country's oldest continuously operated solar energy company. It has achieved international recognition in solar distillation, having developed the only volume produced unit for residential and community sized installations.

Since going public Jan. 16, 1976 Sunwater Co. has initiated a nationwide network of distributors located in Texas, Oklahoma, Colorado, Arizona, California, Florida, Hawaii, Oregon and Utah.

The firm, headquartered at 1112 Pioneer Way, El Cajon, presently has 15,000 square feet in factory utilization. Much of its fabrication is accomplished in Mexico enabling the company to maintain extremely competitive prices. □

NCR ANNOUNCES NEW APPOINTMENTS



William W. Holloway



Kay W. Ross

William W. Holloway and Kay W. Ross have been appointed by NCR Corporation to new positions in the Industrial Relations organization.

Holloway, currently director of industrial relations for Data Processing Division-San Diego, located in Rancho Bernardo, will become Director of Personnel and Employee Relations for Domestic Marketing. He will move to NCR's corporate headquarters in Dayton, Ohio.

Ross, presently director of industrial relations for the Terminal Systems Division in Dayton, will replace Holloway at the division in Rancho Bernardo.

The appointment of Holloway, who joined NCR in 1962, was made by R. Elton White, vice president, Domestic Marketing Administration and Personnel. Ross' appointment was announced by William F. Buster, General Manager of the local division, and vice president, Computer and Communication Systems. □

MORE DIVIDENDS FROM SDG&E

The board of directors of San Diego Gas & Electric Company today declared a quarterly dividend of 30 cents per share on the company's common stock payable April 15, 1976, to shareholders of record March 31, 1976. The dividend is the same as for the last quarter. □

THE WOMEN'S BANK OPENS

The first women's bank in the West, The Women's Bank in San Diego, opened its doors for business March 31, marking the culmination of two years of effort by a small group of San Diego men and women.

The bank, which was incorporated March 19, 1975, was established "so that all persons in San Diego could have a bank where the worth and potential of men and women are recognized equally," according to Rita Mills McCoy, president of the bank.

The Women's Bank is an independent, California state chartered bank, FDIC insured, which opens with \$1.5 million in capitalization. The capital was raised from the sale of stock which sold at \$10 a share. Stock sale was closed Jan. 31, 1976, with 1130 subscribers.

McCoy said the emphasis of the bank will be on bringing San Diego's female population, representing 48% of the city's population and 36% of its work force (1975 figures), into the mainstream of economic life.

"The Women's Bank is not just a bank for women," McCoy stresses. "We will provide a full range of services for all people and businesses... adding the individual consideration and attention which will be our trademark."

In addition to normal, full banking services, The Women's Bank will offer some very special services including free bank-by-mail, extended banking hours and a continuing educational program which will cover a variety of subjects ranging from balancing the books to coping economically with divorce. The educational programs will be offered in various formats including "Brown Bag" lunches for working people and lecture series which continue over a 5-week period. Founders and directors of the bank will be among guest lecturers.

Another special Women's Bank service is called S.O.S., which stands for Special Organizational Services. The Women's Bank has an exclusive in their marketing area on this unique service which provides assistance in straightening out financial affairs to persons in times of stress following divorce or the loss of a spouse.

McCoy, who was one of few bankers offering the service in Marshall, Texas, where she was vice president prior to coming to San Diego, says S.O.S. has a remarkable record of uncovering lost or forgotten insurance policies, effecting difficult claims



Rita Mills McCoy



Victor Diazgranados

and protecting individual's interests. The service will begin shortly after the bank opens.

Another special feature at the bank is a 6' x 6' "playpit," created by noted La Jolla designer Jain Malkin, which is intended to encourage persons with small children to attend to their banking needs personally.

The Women's Bank in San Diego is the first in the West; the second in recent United States history. The First Women's Bank of New York opened in Oct., 1975.

The very first women's bank, however, opened its doors on Oct. 6, 1919 in Clarksville, Tenn., about 10 months before the enactment of the 19th amendment giving women the right to vote. It operated successfully with an all-female workforce until it merged in 1926 with the First Trust and Savings Bank, which is still operating.

McCoy credited the directors and founders of the bank for the successful sale of stock and making possible the opening of the bank. "They're San Diego's busiest, most successful, and most talented men and women who generously gave two years of time, energy and money to this effort," she said.

The bank occupies 2,475 sq. ft. in the Mission Park Building, 5353 Mission Center Road, just south across the parking lot from Victoria Station in Mission Valley. □

ACD ELECTS NEW BOARD MEMBER

Alex C. McDonald, senior partner in the law firm McDonald, Riddle, Hecht & Worley, has been elected a member of the board of directors of Avco Community Developers, Inc. (ACD).

McDonald fills the vacancy created by the death of Paul D. Dodds who had served on the board since 1969.

McDonald is a member of the boards of directors of The Sinfonia of San Diego, the Boys and Girls Aid Society, Ltd., the Community Associations Institute of San Diego and of the board of trustees of the Welfare Foundation of the Lion's Club of San Diego.

He received a B.S. degree from Stanford University, and an L.L.D. degree from the University of California at Berkeley (Boalt Hall Law School).

Avco Community Developers, Inc. is primarily engaged in the development of new communities in Southern California including Rancho Bernardo, Village Park and Windemere in San Diego County, and Laguna Niguel in Orange County. They are headquartered in Rancho Bernardo. ACD is a 77% owned subsidiary of Avco Corp.

MAC LAUGHLIN NAMED TO NEW POST

Gail P. MacLaughlin, advertising manager for San Diego Gas & Electric Company for the past four years, has been appointed assistant director of public relations for the company.

R. Denis Richter, public relations director, said Mrs. MacLaughlin will have major responsibilities in connection with strengthening the capabilities of the public relations department, especially in the area of communications with employees and communities served by the company.

Prior to joining SDG&E, Mrs. MacLaughlin had been active in advertising, promotion and public relations work for more than 15 years. She had been public relations manager for Sea World, Inc., public relations manager for Coronado Cays and promotion manager at the San Diego Convention and Visitors Bureau.

Mrs. MacLaughlin is a past president of the San Diego Public Relations Club, an associate member of the San Diego Chapter, Public Relations Society of American and member of its board of directors, and vice president of San Diego Industrial Advertisers. □



AT ZEL'S

The finest selection of Domestic and Imported Wines, Beer & Spirits! Complimentary ice and glasses for your party! Early orders are appreciated. Diners Club Cards honored. We deliver in Rancho Santa Fe without charge.

ZEL'S PLAZA LIQUOR
 755-9458
 at 15th Street in Del Mar

CLATON TIRE CO.

Franchised Michelin Dealer
 Remington Miller Lee Sumitomo

guaranteed
 RETREADING
 BALANCING
 of any wheel
 UNDERCOATING
 truck and car
 BRAKE SERVICE
 WHEEL ALIGNMENT
 753-6316
 NICK & DOTTIE PHILLIPS
 215 G St., Encinitas

Mobil
 A good deal on a good tire.

**GRANT'S
 MOBIL SERVICE**

CORNER LA FLECHA AND
 LA GRANADA, RANCHO SANTA FE

756-2929

Marshall's

Custom
 Boot Tailoring
 and Cuffs
 Shoe and
 Boot Repairing
 Shoes for
 the Family

755-1776
 112 W. Plaza Solana Beach

Thought-provoking
 Nose-twitching
 Lip-smacking
 Rib-tickling
 CONDIMENTOS

Herbs, spices, chilis — plus salt — for seasoning your favorite and exotic foods. RECIPES INCLUDED. No fuss, no struggle. 100% pure foods.

Send 1 dollar for sample and brochure.
PLATA CONDIMENTOS
 55 East E Street, Encinitas, Ca. 92024

JANE BRETT
RANCHO SANTA FE
REALTOR
756-1442



LA GRANADA & PASEO DELICIAS

R. E. BADGER & SON, INC.

CITRUS GROVE DEVELOPMENT
AND CARE

756-1402

RANCHO SANTA FE

BROWNE & VOGT
Engineering Surveyors, Inc.

726-0920

Construction & Land Surveyors
Engineering & Land Planning

621 South Santa Fe Avenue
Vista, California 92083

Old Damascus RESTAURANT
HOME OF THE FAMOUS SHISH KABAB
Shish Kabab at its best
Authentic Lebanese Food
Exotic mixed drinks
Atmosphere of old Arabia
Truly Cosmopolitan
Lunch Mon.-Fri. 11-2:30
Dinners Mon.-Sat. 5-9:30
3683 Fifth Avenue San Diego
297-3228



MARY'S TACK SHOP
Tack & Veterinary Supplies
Via de la Valle at 76 Station
755-2015

HOME FEDERAL REPORTS SECONDARY MARKET ACTIVITY

Home Federal Savings and Loan Association of San Diego has been able to bring a substantial amount of new money into the California economy through its extensive activity in the secondary mortgage market.

"In 1975, Home Federal increased significantly the amount of money available to California home buyers through its Secondary Mortgage Market activity," explained Vice President Walt Henderson, who is in charge of Home Federal's secondary market activity.

The San Diego-based S & L bought and sold almost \$208 million of home loans dealing with S & Ls and other financial institutions. Home Federal relents these funds to California homeowners. "Industry sources have confirmed that we were the most active S & L in the nation in the secondary market," Henderson said.

He explained that the secondary market is much less formal than the stock market. "There are efforts being made through Amminet, the electronic information system that links those who do business in the secondary market, to organize the market in an exchange-like format.

"The secondary mortgage market allows organizations to earn a steady income through long-term investments in home loans," he said.

In nearly all loan sales, Home Federal retains the title to the loan, selling only a participating interest in the proceeds. The S & L still services the loan. The only difference is that the originating S & L no longer retains all of the income from it. It has traded a share of that income for money which it then re-lends to benefit another home buyer.

Henderson said the secondary mortgage market really came into being after the end of World War II with the home building boom in the West. Life insurance companies found that California home loans were good investments. Eastern lenders and other investors began looking to California and its loan demand which far exceeded that in their own areas.

Home Federal's real estate volume in 1975 was \$567 million. The secondary market mortgage purchases added another \$26 million to that. Secondary market sales were \$182 million during that period.

"There is a continued loan

demand from persons wanting to buy homes in this state," Henderson said, "despite diminished home building activity. As a result California Home Loans are saleable to buyers from the East and Midwest — areas that aren't experiencing the demand for loan money that California is."

The result of secondary market activity has been a stabilization of the construction industry in the state by creating a larger money supply to meet the demand for loans. □

A & G CONCEPTS SHOOTING SEARS COMMERCIALS

A & G Concepts, San Diego's largest television production company, is shooting a series of 60 local television commercials for Sears, Roebuck and Co.

A & G will shoot five commercials a month for 12 months. In addition, the company produced five spots promoting national hardware week at Sears stores in Hawaii, Portland, Seattle, Phoenix, Salt Lake City, Los Angeles, San Diego and throughout middle California.

The spots are being shot at A & G Concepts stage in San Diego, with talent from the San Diego area. Young & Rubicam-Teawell, Inc. is agency for the series of commercials. □

WEST COAST BANK ANNOUNCES APPOINTMENTS

The promotion of John M. Cosh to vice chairman of West Coast National Bank and the appointment of L. Dean Bolar to the position of president was announced today by Elmer Glaser, bank chairman.

Glaser said that the growth of West Coast National Bank, both in size and area of operation, has made it necessary to enlarge the administrative staff and provide for the expanded duties of Cosh.

Glaser said that Bolar would be Chief Executive Officer as well as President and comes to West Coast from American National Bank in Bakersfield where he was Executive Vice President.

Under Bolar's leadership, Glaser said, American National grew from assets of \$17 million to \$170 million in eight years.

Glaser added that with both Cosh and Bolar working on bank development he looks forward to further improvements at West Coast National, not only in the size of the bank but in scope of services which are important to the growing North County area.

FORMER AD MAN JOINS A & G

Tom Merritt, formerly a producer with Arthur Meyerhoff Associates, Inc., a major Chicago advertising agency, has been named executive producer of A & G Concepts, San Diego's largest television production company.

Merritt is a graduate of Columbia College in communicating arts and worked in the advertising industry in Chicago for 13 years, the last nine years with Meyerhoff. He has worked with such clients as Wrigley's Gum, Skil Power Tools, Hires Root Beer, Massey-Ferguson, Brach's Candies, PAM, Old English Furniture Polish and Aero Shave.

"We are building a major television production center in San Diego and have been looking for the right person for executive producer for more than a year," said Phil Arenson, A & G Concepts president. "Tom Merritt has the professional background and personal qualities we wanted and we are fortunate to have him join us."

A & G Concepts is a full-service television production company with corporate offices at 1660 Hotel Circle, San Diego. It is one of the few companies in the country now using the CMX-50 computerized editing system. Since its formation in 1970, A & G Concepts has written, produced, directed and edited more than 600 television series, commercials, specials, documentaries and training films for local, national and international clients. □

HOME FEDERAL SETS SUMMER OPENING

"We're terrifically excited about our new office," said Tom Peterson, manager of Home Federal Savings and Loan Association of San Diego's Carlsbad office. "The community has given us such a wonderful reception, that we're looking forward to serving it even better from our expanded facility." The construction site at 2560 El Camino Real is directly adjacent to the temporary office now in use.

The two-story, 9,060 square foot building, which was begun in November, is scheduled for completion in late July.

Frank L. Hope and Associates Architects have planned the exterior to complement the Spanish flavor of nearby Mission San Luis Rey.

Peterson said, "We are fortunate to have obtained such a convenient location."

Shops and Services Directory

★ **AIR CONDITIONING & HEATING**



STILLMAN HEATING & AIR CONDITIONING INC.
Sheet Metal Work, Gutters, Downspouts, Kitchen Equipment, Ventilating, Solar Heating, Lic. #290240 — Free Estimates
1240 N. Highway 101, Leucadia 753-4583

★ **AIRCRAFT CHARTER & RENTALS / TRAINING / SALES**

Brad & Mary Pearson's **FLIGHT TRAILS, INC.**
at Palomar Airport
VA-FAA Approved
438-4797 — 744-2003

★ **AIRLINE TICKETING**

CHOICE TRAVEL SERVICE
Agents for All Airlines
In Encinitas: 149 D St., 753-6211
In Solana Beach: 927 Lomas Santa Fe Dr. 755-0218

★ **ANIMAL CARE CENTERS**



A PET CARE CENTER
All Breed Pet Grooming
Bichon Frise & Poodle Show Trims
Heated Geriatric Runs
24 Hour Supervision
ALCALA (714) 436-6619
1273 Crest Drive, Encinitas, CA 92024



ANIMAL CARE CENTER
THE ULTIMATE IN PET CARE & COMFORT
Individual Air Conditioned & Heated Runs
Science & RX Diets
Daily Veterinary Supervision
Medicated or Regular Baths
Visitation Encouraged
Hours 9 a.m. - 5 p.m. Daily
1328 W. Mission Rd., Escondido 747-4100

★ **ANSWERING SERVICES**

TRI-COMMUNITY ANSWERING SERVICE & PHYSICIANS EXCHANGE
Serving San Dieguito Area
• Member TASC
24 Hour Service
Member TASC • 24 Hour Service
433 Santa Fe Drive, Encinitas 753-6565

★ **ANTIQUES**

COTSWOLD COTTAGE ANTIQUES
Fine Furniture French • Oak • Victorian • Paintings • Collectables • Orientals • Art Glass • China
Brass • Copper • Silver
Closed Sunday and Monday
110 S. Ditmar, Oceanside 722-9633
Mon.-Fri. 10-4

★ **ANTIQUES**

ANTIQUÉ CLOCK SHOP
1340 No. Hwy. 101, Leucadia 753-8844
European weight/spring clocks
Large selection European furniture
American & English oak. Cut glass 9-4 Wed-Sun.

Take a step into the past at **POWAY VILLAGE ANTIQUES**
"We Buy Antiques"
specializing in furniture
antique doll and toy museum
Hours: 11 to 5, Closed Mon. & Tues.
Old Poway Midland Rd. & Aubrey St. 748-3240

FURNITURE REFINISHING
24 years experience
Free pick up and delivery
SAL SALGADO FURNITURE REFINISHING
116 E. 6th Ave., Esc. 743-9959

★ **APPLIANCE SALES & SERVICE**

MART'S APPLIANCE SERVICE
"Guaranteed Small Appliance Repairing"
Complete Line of Parts
Electric Shavers — Custom Lamps
336 E. Grand, Escondido 745-7711

★ **ART GALLERIES**

CARROUSEL ART GALLERY
541 First St. Encinitas 753-8472
Original paintings · Oil · Acrylic
Watercolors · Graphics · Batik · Ceramics
Open 10:00 a.m. to 5:00 p.m. daily.

GRAYS GALLERY
Original Art — Gifts — Custom Framing
12:30 to 5:30 Tues. thru Sat.
Ceramics · Paintings · Wood Carvings
231 S. Juniper, Escondido 746-5226

FINE OIL PAINTINGS
for Rent or Purchase
Kennedy Studio & Art Gallery
722H Genevieve St.
Solana Beach, CA 92075
755-5281
Across from Fidel's Restaurant

★ **ART SUPPLIES**

THE PAINT POT
632 First St., Encinitas 753-7021
Winsor & Newton • Grumbacher • Liquitex
for the commercial artist, designer, student.
Picture framing. Domestic & Imported papers

★ **AUTOMOBILE SERVICE**

DEL MAR GERMAN CAR SERVICE INC.
155 Carmel Valley Rd., Del Mar
755-1652, 459-7766
Specializing in Volkswagen, Porsche, BMW, Audi, Volvo. Open Tuesday-Saturday 8am-5pm

★ **AUTOMOBILES/VINTAGE**

SMITH & MARSEE VINTAGE
Motor Car Sales
Fine, vintage motor cars
530 No. Highway 101, Leucadia 753-9475

★ **AWARDS**

GLASER-BAILEY TROPHIES
Awards — Plaques — Gifts — Engraving
Hours: 9:00 a.m.-5:30 p.m.
Evenings By Appointment
1310 S. Escondido Blvd., Escondido 743-5551

★ **BEAUTY SALON / BOUTIQUE**

THE LEMON TREE
The latest hair style for ladies and gentlemen.
Stereo hairdryers — Refreshing facials — The latest fashions and jewelry for women of distinction — Gifts
FELICITA PLAZA
Hwy. 395 & Felicita Ave., Escondido 743-3877

★ **BICYCLES**

POWAY PEDALER
New - Used - Repairs - All Makes
Complete Line of Bicycle Motor Cross
We're Here To Serve You
12845 Poway Rd. 748-8655

★ **BICYCLES — SCHWINN**

HIDDEN VALLEY BICYCLE STORE
Largest stock of new bicycles. Also expert repairs on all makes; tires, etc.
245 West Washington Avenue
Escondido 746-1509

McDOUGALL'S COAST CYCLERY SCHWINN
Service on All Makes
533 First St., Encinitas, CA 753-5867

★ **BLACK TOP, EXCAVATION**

SMITH CONSTRUCTION COMPANY
See Us for All Your Paving Needs...
Black Top, Excavation Top Soil & Fill Dirt
756-1601 and 753-2796

★ **BOOKS**

CASA DE NOVEDADES
Paperbacks - magazines - book rentals - stationery
tobaccos - camera supplies & developing
The Mercado
11844 Rancho Bernardo Rd. 487-2114

★ **BUILDING DESIGN**

GEORGE MARGIEN
The finer things — In any style
"Since 1946"
Paseo Delicias, next to the Country Friends
Rancho Santa Fe 756-3696

★ **BRAKES**

COAST BRAKE & WHEEL SERVICE
Mufflers — Goodyear Tires
Brakes — Wheel Alignment
444 First St., Hwy. 101, Encinitas 753-6272

★ **CABINET MAKING**

CUSTOM CRAFT CABINETS
Specializing in Custom Cabinets
Contractor License #287334
1342 Industrial Ave., Escondido 743-0881

Shops and Services Directory

★ CANDY

THE CHOCOLATE TREE

For famous hand dipped chocolates — imported candy specialists — delicious warm fresh nuts. Free Delivery in Rancho Bernardo

Phone 487-2333
Rancho Bernardo Road

★ CARPET CLEANING SERVICE

In Rancho Bernardo it's AAA HOME CLEANING SERVICE Distinctive Cleaners of Carpets — Upholstery — Drapes
References Gladly Furnished
Call for free estimate.
281-8180

SMITTY'S OF LA JOLLA, INC.
CARPET CLEANING
"Steamway Method"
Specializing in wall-to-wall carpet!
28 Years in La Jolla
459-3269

SOLANA CARPET CLEANERS
The Finest in Professional Cleaning
NEW JET "STEAM"
The First of Its Kind on the West Coast
All in One Gentle Action — No Brushes
REPAIRING — RESTRETCHING
753-2511

★ CARPETS & DRAPES

CARRIAGE HOME DECORATING CENTER
Floor Coverings - Custom Drapes
Wallpapers - Paints - Imported Tiles
12845 Poway Rd., Poway 748-5700 - 566-2220

★ CARPET & LINOLEUM

ESCONDIDO LINOLEUM & CARPET, INC.
Our 30th year in business
Carpeting - Vinyl Floor Covering - Formica Resilient Tile
462 N. Elm, Escondido 745-5821

★ CARPET & UPHOLSTERY

In Rancho Bernardo it's AAA HOME CLEANING SERVICE Distinctive Cleaners of Carpets — Upholstery — Drapes
References Gladly Furnished
Call for free estimate.
281-8080

★ CLEANERS

Complete cleaning service. Knitwear cleaned and blocked to fit. Complete alteration department. Hand laundered shirt service. Draperies, household and sleeping bags. Six days — 8 to 6. Drive in. Popular prices. 1 day service.
CARSON DRY CLEANERS
1240 S. Escondido Blvd. 747-0733
"We own and operate our own plant!"

VILLAGE CLEANERS

1-day Service
We Operate Our Own Plant
Drapery Specialist
Rancho Santa Fe 756-1483

★ CRYSTAL REPAIRING

Expert Crystal Repair — Also specializing in hand-cut personalized monogrammed glassware.
JULIE'S GLASSWARE
1851 A West Vista Way
Vista, CA Phone (714) 724-6381

★ DANCE — DRAMA

STRATFORD COURT STUDIO THEATRE
Ballet • Tap • Yoga • Tai Chi • Modern Jazz • Gymnastics • Theatre Training
Marilu Norden, Director
1355 Stratford Ct., Del Mar 755-1702

★ DRESSMAKING

CUSTOM DRESS MAKING ALTERATIONS
CAYO 487-2218 or 744-0423

★ ELECTRICAL CONTRACTORS / REPAIRS

— 24 Hour Emergency Service —
G & C ELECTRIC SERVICE
Residential • Commercial • Installation • Repairs
State Contractors Lic. #288842
753-3581 or 453-7963 Emergency 753-3085

★ ENGINEERING SURVEYORS

"BROWNE AND VOGT"
ENGINEERING SURVEYORS, INC.
726-0920
• Subdivision
• Land Surveys
• Topographical Surveys
621 S. Santa Fe Ave., Vista, CA 92803

★ EQUIPMENT RENTALS

POWAY EQUIPMENT RENTAL
Contractors & Home Owners Equipment
U-HAUL TRUCKS & TRAILERS
Free Instructions with Purchases
13044 Poway Rd., Poway 748-3722

★ FABRIC

STITCH 'N SEW SEWING CENTER
Featuring finest in knits & wovens
Kwik Sew - Jean Hardy - McCalls Patterns
Easy Sew Classes - Sewing Machines
Carriage Center 12845 Poway Rd. 748-4620

★ FEED & TACK

H & H FEED COMPANY
Complete Tack Shop — Veterinary Supplies
Kelly • Purina • Universal
Hay Sold by Bale or Ton
Major Brands of Cat & Dog Food
We are as near as your phone.
FREE DELIVERY
1985 Olivenhain Rd. 753-8050

★ PHOTOGRAPHY

HOUSE OF PORTRAITS
Portraits our specialty
Weddings Commercial
Passport Photos
By Appointment
HOUSE OF PORTRAITS
Tony Francis, Photographer
1430 Camino Del Mar, Del Mar, CA 755-9347

★ FIREPLACE EQUIPMENT

BRASS TOWN
Since 1952
Fireplace Screens & Accessories
Gas Log, Metal Fireplaces
Wall Decor, Gifts
Experience - Service - Quality
2 Locations to Serve You
902 W. Washington St., San Diego 296-2727
1417 S. Escondido Blvd., Escondido 747-0350

★ THE VILLAGE FORGE

Custom Firescreens
Tools and Accessories
Real Fyre® Gas Logs on Display
1646 Hwy. 101, Leucadia 753-1641

★ FLORISTS

Garden-Fresh Flowers and everything for the Do-It-Yourself enthusiast.
744-1634

SAN MARCOS FLORIST
175 S. Rancho Santa Fe San Marcos, CA
(Next to Bank of America)

★ FUNERAL DIRECTORS

EL CAMINO MORTUARY
and MEMORIAL PARK
The finest in funeral, cemetery, mausoleum and crematory facilities; now available in one place.
AN ENDOWMENT CARE INSTITUTION
SERVING ALL FAITHS AND ETHNIC GROUPS
453-2121
9450 Carroll Canyon Rd., San Diego

McLEOD MORTUARY
Continuing More Than Forty Years of
Community Service
1919 E. Valley Parkway
Escondido, CA 92027 Area (714) 745-2100

★ FURNITURE RESTORATION

ERIC MASTERMAN
Furniture Restoration
Repairing and Refinishing
25 Years London Experience
P.O. Box 296, Del Mar 755-9273

★ GLASS SERVICE & SUPPLIES

ENCINITAS GLASS CO.
We Are Glass Specialists
Prompt Breakage Replacement
Auto Glass — Foreign & Domestic
Insurance Work — Home & Auto
687 2nd St. Encinitas 753-6361

★ GUTTERS & DOWNSPOUTS

Custom Rain Carrying Equipment
Free Estimates
J. T. JOHNSON
747-4946

★ HAIR DESIGN

Professional men's and women's hair styling.
Famous London school technique.
Open Tuesday through Saturday 9:30 a.m.
Evenings by appointment
THE HEAD SET
1130 D Camino Del Mar, Del Mar 755-2562

★ HEALTH FOOD STORES

ZARVELL'S
Raw Honeys, nuts, dates, dairy, produce,
shampoos, and vitamins
755-0957
1153 Camino Del Mar, Del Mar
Hours 9 a.m. until 8 p.m.
(Closed Sundays)

★ HEARING

SONOTONE of ESCONDIDO
— House of Hearing —
• Testing • Full Service
• Complete Line of Hearing Aids
240 E. Grand Ave., Escondido 746-3474

★ HORSES/BOARDING



Rancho Del Mar 481-0612
Via de la Via & El Camino Real, Near I-5
BOARDING — INSTRUCTION
(Beginning - Advanced) Sales
ANNE & BOB SPECK — Owners
Melissa Montague — Instructor

★ JEWELERS

CALIFORNIA JEWELERS
481-0707
536 Stevens Ave. (Stevens Sq.) Solana Beach
Custom Designs • Gems • Repairs
All Work Done on Premises
Lay Aways - BankAmericard - Master Charge
American Express

★ KENNELS

FALCONMOOR KENNELS
— Excellent rating since 1959 —
BOARDING — GROOMING
SHOW CONDITIONING
1049 E. Mission Road, San Marcos
745-2759

★ LANDSCAPE ARCHITECTS

TUCKER & KATER
LANDSCAPE ARCHITECTS
Telephone: 436-3085
Professional Landscape Architect and Site Planning, Design and Consultation Services.
582 First St., Suite 2
Encinitas, Ca. 92024

★ LUMBER SUPPLIES

ENCINITAS LUMBER
Building Materials • Tools • Hardware • Electrical
• Paints
745 First St. 753-1148 Encinitas

★ MASSAGE

WASHINGTON MASSAGE & SAUNA
A very nice place to relax while your tensions drift away. Please stop by . . . 157 W. Washington Ave. (off U.S.395)
Escondido daily till 2:30 a.m. 746-4050

★ MEAT MARKETS

BOB FISK MEAT MARKET
"Choice Meats Cut to Order"
Barbecued Chicken — Selected Cheeses
12815 Poway Road, Poway
748-0741
"Next to Shakey's"

★ MOVING & STORAGE

BERNARDO MOVING, INC.
Local and World-Wide Moving
Crating — Packing — Storage
Lou P. Caffar, President
(A Rancho Bernardo Resident)
"We are right here to help you like it here."
17024 Grandee Way, Rancho Bernardo
487-4256 Off. 487-0609 Res.
Agent for John F. Ivory Storage Co., Inc.
Detroit, Michigan

★ MUSICAL INSTRUMENTS

BLUE RIDGE MUSIC
Lessons • Repairs
All Stringed Instruments & Accessories
Fender • Guild • Gibson • Yamaha • Mossman
568 First St., Encinitas 753-1775

REESE MUSIC CENTER
Pianos — Thomas Organs — Hi-Fi
CONN—SELMER—YAMAHA INSTRUMENTS
Escondido's Oldest, Largest Music Store
418 E. Grand, Escondido 745-7321

★ MUSICAL INSTRUMENTS

BLUE RIDGE MUSIC
Lessons • Repairs
All Stringed Instruments & Accessories
C.F. Martin • Guild • Peavey • Sigma • Takemine
509 S. Highway 101, Encinitas 753-1775

POWAY MUSIC
Pianos - Organs - Musical Instruments
Guitars - Instruction - Repair
(located in the Music Hall)
12845 Poway Rd., Poway 748-0880

VILLAGE MUSIC CENTER
LESSONS • REPAIRS • PIANO TUNING
All Band Instruments and Accessories
Drums, Guitars, P.A. Systems, Amps
Sheet Music, Records, Tapes, Special Orders
METRO - TICKETRON - ALL SPORTS ARENA
EVENTS

Encinitas 1466 Encinitas Blvd. 436-5696
VILLAGE SQUARE, NEXT TO VILLAGE PARK

★ OPTICIANS

744-0864
BIFOCALS, PHOTOSUN, PHOTO RAYS,
CONTACT LENSES.
ONE DAY SERVICE ON MOST
PRESCRIPTIONS
SAN MARCOS OPTICIANS
225 N. Rancho Santa Fe Rd., Suite 206
San Marcos, CA

★ ORIENTAL RUGS

WANTED: Oriental Rugs in any condition from individuals and estates.
SHAH ABBAS — ORIENTAL RUGS
at the Mercado in Rancho Bernardo
11844 Rancho Bernardo Rd. 487-1940

★ ORNAMENTAL IRON

THE VILLAGE FORGE
Quality Custom Work
Gates — Railings — Window Guards
Wrought Iron Americana and Imports
Metal Sculpture — Custom Firecreens
1646 Hwy. 101, Leucadia 753-1641

★ PAINT & WALLPAPER

CARRIAGE HOME DECORATING CENTER
Floor Coverings - Custom Drapes
Wallpapers - Paints - Imported Tiles
12845 Poway Rd., Poway 748-5700 - 566-2220

★ PAINTING CONTRACTORS

PARIS OF DEL MAR
Serving San Dieguito Area Since 1942
R. L. Paris
Bonded • Insured • Lic. #126559
Quality Materials and Workmanship
344 14th St., Del Mar 755-2883

★ PHARMACY

JERRY'S PHARMACY
"Quality and Service at Yesterday's Prices"
748-9330
12451 Poway Rd. M-F 9-6 — Sat. 9-2

★ PHOTOGRAPHIC SUPPLIES

GAILEY'S PHOTO SUPPLY, INC.
Escondido's most complete Photo Supply
Since 1948
Featuring Kodak Color Processing
118 E. Grand Ave., Escondido 745-7823

RB Photo Art Crafts
Kodak Processing
Camera Repair
Custom Picture Framing
on the square - near von's 487-5542

★ PIANO TUNING & REPAIRING

JOHN KITZMILLER
Tuner-Technician
Registered member of Piano Technicians Guild
487-7961

★ PICTURE FRAMING

THE FRAMEWORKS
Picture Framing
Matting - Repairing
Jim Beeson
753-9988
830A First Street, Encinitas

RB Photo Art Crafts
Custom Picture Framing
Kodak Processing
Camera Repair
on the square - near von's 487-5542

★ PLANTS

THE FOUR SEASONS SHOP
House and Patio Plants, Pottery,
Macrame, Iron Plant Holders,
Imported Gift Items, Worms
12823 Pomerado Rd. Poway
1 block So. of Poway Rd.
M-S 10-6 — S 12-5 748-3066

★ PLASTICS & SUPPLIES

PRECISION PLASTICS has qualified technical fabricators to do the most complicated precision parts, or the simplest of home decorator items. Our supplies range from plastic cleaner to super strength bonding solvent. Stop in and talk to one of our decorators or call 225-0033.
PRECISION PLASTICS
3171 Sports Arena Blvd., San Diego
8363 Center Drive, La Mesa

★ PLUMBING

J.L.G.
CUSTOM PLUMBING
Residential • Commercial • Industrial
NEW CONSTRUCTION REMODEL
Repair Service Drain Cleaning Water Heaters
Lic. #304124 Joe L. Galvao
714/741-0582 or 747-6931

★ PLUMBING CONTRACTORS

Repairs — Remodeling — New
Water Heaters — Garbage Disposals
Furnaces — Plumbing Supplies
OLEN L. COOK
Escondido 456 E. El Norte Parkway 745-5375
Lic. #159907

COAST PLUMBING, INC.
P.O. Box 715 — 2120 Jimmy Durante Blvd.
Del Mar 755-1888 436-4567
"Fast, Dependable, Complete Service"
Repairs, Remodeling, New Construction
Lic. #208123

★ PRIVATE SCHOOLS

Santa Fe Montessori School
Ages 2½-11 years
Summer Program Day Camp
1010 Solana Drive, Solana Beach
Nancy T. Sager/Director 755-3232

★ **PRODUCE**

FUKUDA BROS. PRODUCE
"Quality Fresh Strawberries and Tomatoes"
MISCELLANEOUS FRUITS AND
VEGETABLES IN SEASON
2412 S. Escondido Blvd., Escondido 745-8951

★ **RAIN GUTTERS**

THE
RAIN GUTTER
SPECIALIST
Give your home that finished "picture frame look"
while protecting it at the same time!
Estimates freely given.
ED GRAHAM
"The Rain Gutter Specialist"
434-1857
4540 Trieste Drive Carlsbad
State Contractors License #214082

★ **REAL ESTATE**

ART LEITCH, REALTOR
7827 Ivanhoe, La Jolla 459-3833
Complete Real Estate Service
Escrow • Mortgage • Insurance
Open Monday through Saturday

REUTER REALTY 753-0101
1354 North Highway 101, Leucadia
27818 Valley Center Rd., Valley Center 749-0347
Complete Real Estate Service for North County

★ **REMODELING CONTRACTOR**

Your best investment — property! Keep values high. For quality remodeling — additions — new kitchens — patios, call Sherm Williams at 727-1713 days or 727-7539 evenings.
SANDALWOOD ENTERPRISES
A reliable general contractor.
18 Years in North County
State Lic. #192212

★ **RESTAURANTS**

Where Connoisseurs Conven
Until 2:00 a.m.
CARNEGIE A-440 PIZZA HALL
755-6778
2212 Carmel Valley Rd. Del Mar

"Tastefully Yours"
THOMAS DINNER HOUSE 481-0184
552 Stevens Ave., Solana Beach
We Now Offer Complete Catering Service
Open Daily 5 p.m.

★ **RENTALS, PARTY**

ACTION RENTALS
(formerly Goodhews)
Medical Oxygen, Sickroom Supplies,
Party Rentals, Canopies
"Fastest Service in North County"
746-1144 618 North Broadway Escondido, CA

THINGS TO RENT
FOR EVERY EVENING
TAYLOR RENTAL
Center
748-3300 13219 Poway Rd. 566-3300

UNLIMITED RENT ALL
Complete Party Equipment
Including
Banquet Tables, Canopy Tents, Patio Heaters
China and Silver
UNITE RENT ALL
1150 E. Washington Ave. Escondido 747-0303

★ **RIDING APPAREL ENGLISH/WESTERN**

CHARLIE'S RIDING HABIT
748-0360
"A Good Habit to Get Into"
Custom made English & Western riding attire for
the equestrian.
Charlie Ligon (after 6:30 p.m. 748-5542)
Fittings by appointment. Poway 748-0360

WESTERN TACK & TOGS
Western apparel for everyone.
Boots, jewelry, famous brand leather goods, feed
and veterinarian supplies. Men's casual wear.
14029 Midland Rd., Old Poway 748-0360

★ **ROOFING**

ROOFING OF EVERY TYPE
Wood Shingle — Shake — Composition
Tile — Bermuda Insulated Roofs
— REPAIRS —
WITHEROW ROOFING CO. - 747-1101

★ **RUBBISH COLLECTION**

RANCHO SANTA FE DISPOSAL
Trash Pick-Up
Plastic bags on convenient rolls available.
Also Construction Site Preparation
and Clean-Up
753-4157 or 753-7378

★ **SCREENS**

Replace Damaged Screens
Replace Broken Windows
Repair Hard to Operate Windows
Reverse Sliding Windows
Reverse Sliding Glass Doors
TED BUSCH 747-7984

★ **SHOE REPAIR**

HUBERT'S SHOE REPAIR
Expert Shoe Repair
Custom Leather Sandals
Leather Harness Repair
476 B Street, Encinitas 436-1777

★ **STOCK & BOND BROKERS**

BATEMAN EICHLER, HILL RICHARDS, INC.
Member New York Stock Exchange
Dunae McBride
12405 Rancho Bernardo Rd. 487-4140

★ **SWIMMING POOLS**

Custom Pools Designed and Built
by DEL RANCHO POOLS, INC.
Maintenance • Repairs • Supplies
Pool-Sweep & Kool Decking a Specialty
1163 First St., Encinitas 753-6369

★ **SWIMMING POOL SERVICE**

PHILLIPS POOL SERVICE
We're Proud of Our Excellent Reputation
Maintenance & Recreation Supplies
Acid Washing • Expert Repairs • Free Estimates
2784 State St., Carlsbad 729-1842

★ **TRAVEL**

CHOICE TRAVEL SERVICE
Complete Travel Service
Airlines • Cruises • Tours
Encinitas: 149 D St., 753-6211
Solana Beach: 927 Lomas Santa Fe
755-0218

CARRIAGE TRAVEL BUREAU
Complete Travel Services
Air Lines - Amtrak - Tours - Cruises
Hotel Reservations - Car Rental - Etc.
Carriage Center 748-8511
12845 Poway Rd., Poway 566-9040

★ **TV RADIO SALES & SERVICE**

MIKE'S TV
Authorized Quasar Sales & Service
QUALITY TV CENTER
Service Most Makes TV & Radio
12717 Poway Rd., Poway 748-7155

POWAY TV
Service & Repair
Authorized Philco Dealer
748-6000 — 12459 Poway Rd. — 748-3778

RANCHO BERNARDO TELEVISION
FACTORY AUTHORIZED SALES & SERVICE
"WE SERVICE ALL MAKES"
25 YEARS OF EXPERIENCE
Rick Siebert, owner & resident
ZENITH Westwood Shopping Center SONY
11641 Duenda Rd. 485-5807

ROY'S TV
"Serving this area for 29 years."
AUTHORIZED ZENITH SALES & SERVICE
Expert Service on All Makes
314 East Grand, Escondido 745-5741

★ **UPHOLSTERY**

HOLLIS UPHOLSTERY
Restyling & Repairing
Free est., pickup & delivery
5 yr. workmanship guarantee
748-5015
12344 Oak Knoll Rd. Poway

★ **WALLPAPER**

THE WALLPAPER PLACE
753-7021
632 First Street, Encinitas
Distinctive Wallcoverings
Over 600 books - 70,000 patterns
We Color Match Paints

★ **WESTERN WEAR**

WESTERN TACK & TOGS
Western apparel for everyone. Boots, men's casual
wear. Double knit pants. Leather goods. Western
tack and supplies for your horse.
14029 Midland Rd., Old Poway 748-0360

★ **WIGS**

RENEE'S WIGS 459-8838
Specializing in Human Hair Imports • Difficult
Sizes & Colors • All Types Expert Restyling, Siz-
ing and Coloring.
7605 Girard Avenue La Jolla

★ **WINDOW CLEANING**

ARM-STRONG
Cleaning Contracting
Residential and Commercial Cleaning
WINDOW SPECIALISTS
Household Cleaning
Hard Floors • Free Estimates
MIKE MORGAN (Owner)
Escondido 747-0055

★ **WINES & SPIRITS**

LA BODEGA WINES & SPIRITS 481-8148
2626 Del Mar Heights Rd., Del Mar
Offering the most extensive California wine
selection. Your spiritual advisor. Complete
party & catering arrangements. Delivery service.

THE
SHOPPER'S
BAZAAR



The most charming furniture store
in North County! Specializing
entirely in Early American, Colonial
and Provincial furniture and rugs.

"Only the finest in home furnishings"
Complete decorating service
available.

THE WAYSIDE SHOP
345 West Grand, Downtown Escondido
745-1001



50th
YEAR
OF
SERVICE

546 South Redwood
ESCONDIDO 745-6913
SAN DIEGO 283-3181



Leonardo's

Complete Hair Styling
& good old fashioned
hair cutting
Men's, Children's, Ladies
Manicurist Thurs. & Fri.

Call 487-8022 For an Appointment
The Mercado — Upstairs
Mon.-Sat. 9-6 Rancho Bernardo, Ca.



LEE SMITH
Proudly
Announces
His
GRAND
OPENING
1737 S. Escondido Blvd.
Escondido
741-0434
DRAPERIES
WALLPAPER
VINYL FLOORING



Thinker
Things

Unique & Creative Toys
743-8822
Felicitia Village
330 West Felicitia Avenue
Escondido, California 92025



RB
BARBER SHOP

Complete Barber Shop, Men's Hair
Styling, Women's Hair Cuts, and
Shoe Shine.
Women's Hair Cuts a Specialty
(Appointments Preferred)

Open 9 to 6 Mon.-Fri.
Saturday 9 to 5:30
487-2500
12459 Rancho Bernardo Rd.



OWN A PIECE OF THE ROCK

Prudential

Estate Planning
Business Insurance
Mortgage Insurance
Life/Health/Annuities

ROBERT J. FISHER, C.L.U.
Rancho Bernardo 487-4843

2026.008.047

010

047



“Children’s Heritage”

... theme of the Children’s Hospital and Health Center Fair to be held Saturday, May 22, from 9 am ‘til 2 pm, at the Sports Arena. Free admission. Handcrafted items on sale, with proceeds going to the Children’s Hospital and Health Center.

Compliments of Home Federal Savings and Loan Association of San Diego.