

*"Winning Backgammon" 1.50
 gives finer points of game. Official rules
 and instructions for duplicate backgammon*

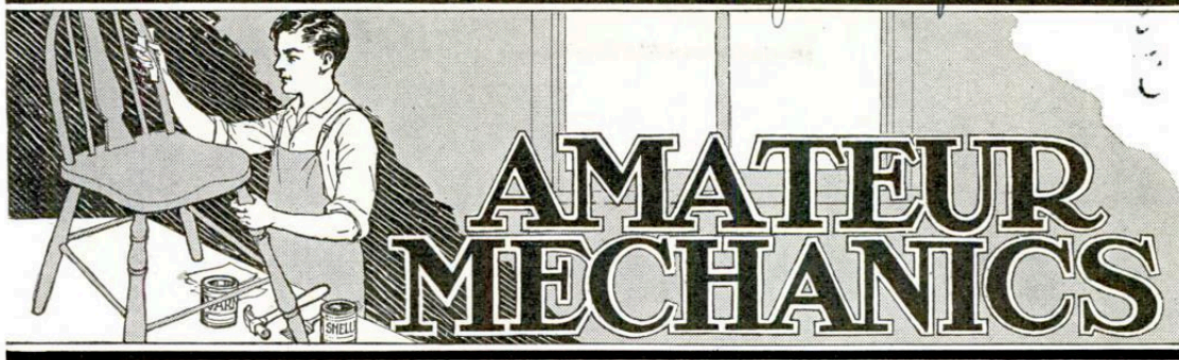

Inlaid Backgammon Board Easy to Make

THE OLD GAME of backgammon has returned to favor, and bids fair to supplant bridge in the hearts of many devotees. The inlaid book-type board, described in this article, should make a hit with any backgammon fan, and is comparatively easy to make, since, contrary to most inlaid jobs, the construction en-

tirely eliminates the necessity of routing. The first step in making the board is to cut 12 pieces each from holly and ebony, to the dimensions shown in Fig. 1, with the grain running lengthwise of the points, as they are called. A simple method of cutting these points on the power saw is shown in Fig. 2. Tilt the crosscut guide

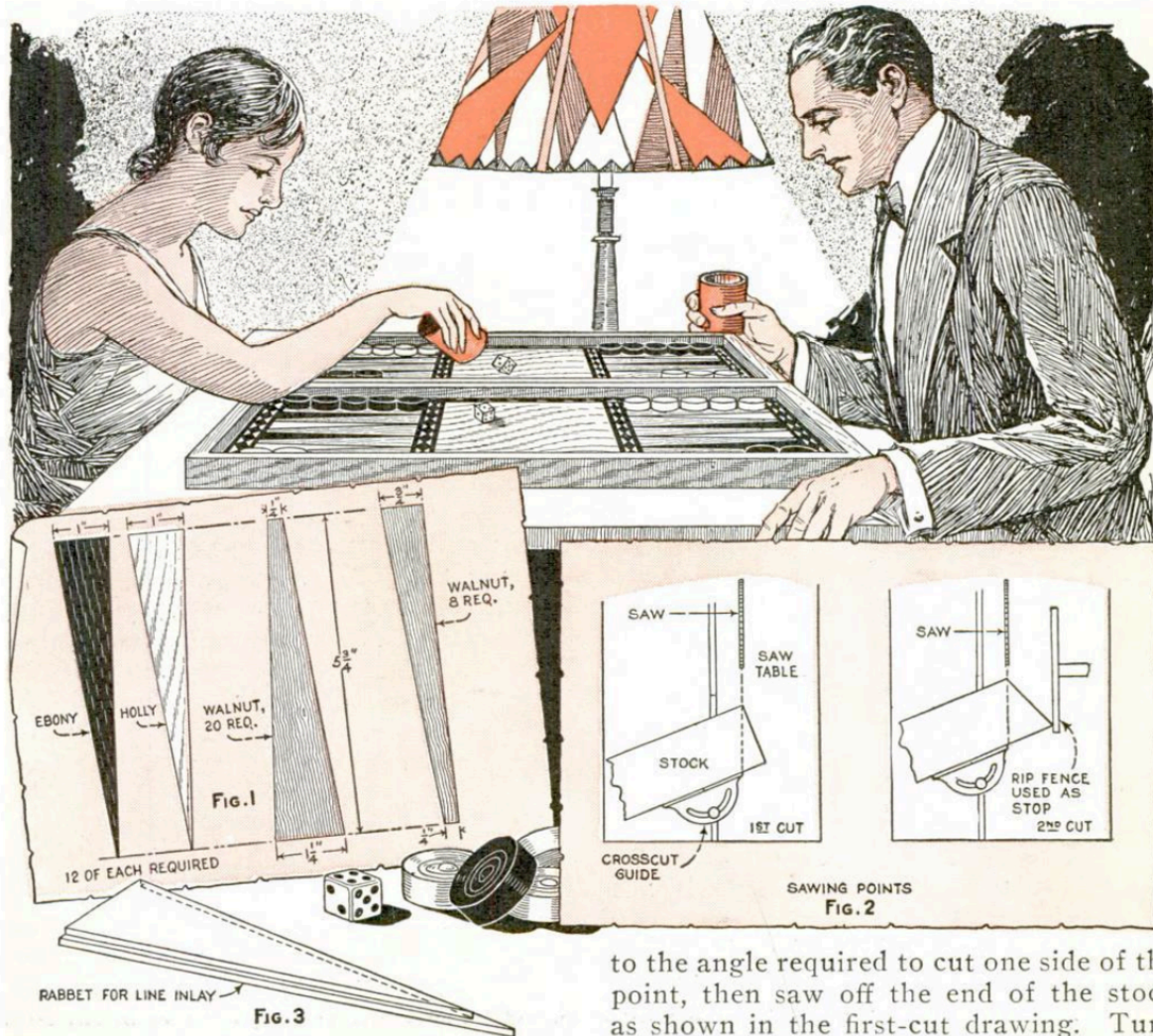

to the angle required to cut one side of the point, then saw off the end of the stock as shown in the first-cut drawing. Turn

*166 W. 74th Street
 Marguetry Corp. / Park Ave. Heights
 Krenzel & Lutenbergs
 d. van*

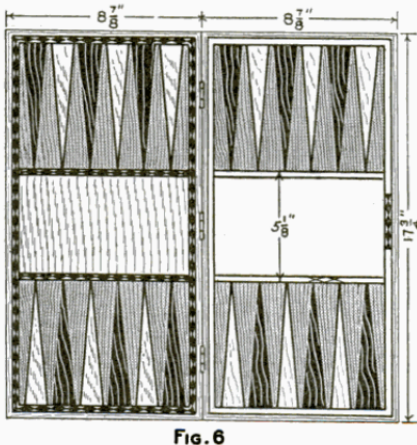
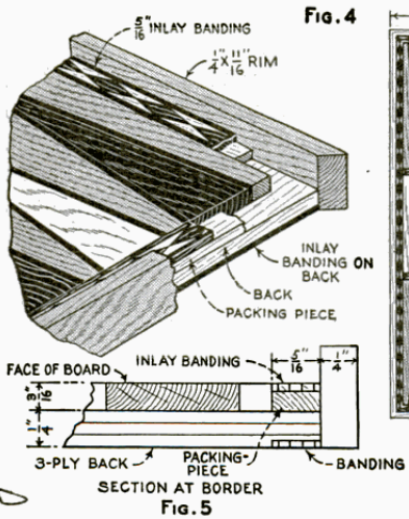
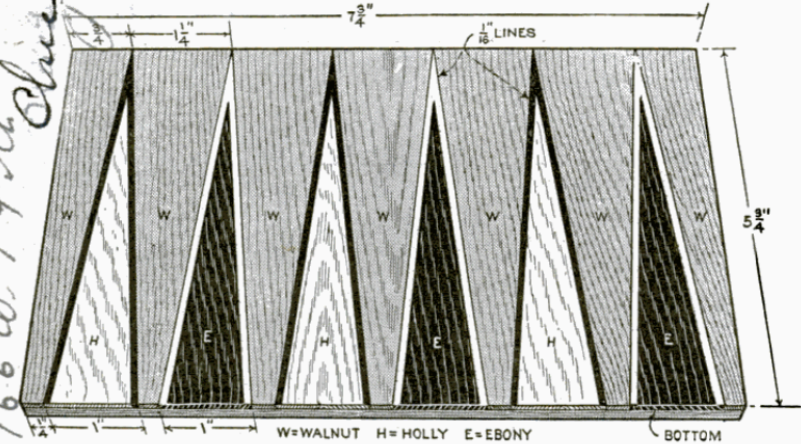

the stock over and adjust the rip fence, with the long point of the stock against it, until the length of the point base, when cut, will be exactly 1 in., then make the second cut as shown. To cut off another point exactly similar to the first, merely turn the stock over and cut again. By this means all the points are cut exactly alike. The walnut pieces that go between the points on the board are cut in a similar manner, to the dimensions given in Fig. 1.

After cutting, the holly and ebony points are rabbeted on the edges, as shown in Fig. 3, to take the 1/16-in. celluloid "white-line" and "black-line" inlay bandings sold by marquetry-supply houses. It will be seen that when the points are assembled on a base, with the walnut triangles between, as shown in Fig. 4, the rabbets on the edges of the points form grooves to take the white and black lines, without any routing.

The backing on which the pieces are glued down may be a piece of three-ply, one side walnut, 8 3/8 by 17 1/4-in., or a solid

piece of 1/4-in. walnut. Before assembling, run a 5/16-in. rabbet right around the outer edge of this piece, on the walnut side, if three-ply is used, or on what will be the underside if solid stuff. This rabbet, when the rim is applied, forms the groove for the 5/16-in. inlay banding shown in the back view, Fig. 8, and in section, Fig. 5. One assembly of points is glued down at each end of the bottom board, 5/16 in. from the end, and then the centerpiece, shown in Fig. 7, is glued between them, the rabbets at each end of this piece also automatically forming grooves for inlay banding. It will be noticed, in Fig. 6, that a holly point on one end of the board is assembled opposite an ebony point on the other end, and so on across the board.

Notice also, in the same drawing, that the alternate arrangement of the points is carried out across the other section of the board. When assembling, use good glue, and be careful that none of the pieces slip when clamped. When dry, glue in the white and black lines, being careful to get close joints at the apex of each point, then glue in the inlay-banding edging and the banding strips across the face of the board. It is well to have all the lining and inlay banding on hand before starting the job, so that the rabbets can be cut to suit the thickness of the stock, which varies a trifle now and then. When fitting the banding to the edges of the boards, try to match the pattern at the mitered corners as closely as possible. Scrape and sand each inlaid surface level and smooth.

Turn the board over, and glue and brad on the 1/4 by 1 1/16-in. walnut rim, keeping the bottom edge of the rim level with the center of the board, thus forming the groove for the banding on the back, and mitering the corners as indicated in Fig. 8. Glue in the banding on the back, Fig.

8; then sand and scrape the surface of the board, banding and rim down to a level surface. The other section of the board is assembled in a similar manner, and then the two sections are hinged together, and the rims fitted, if necessary, so that they close with a good joint. Remove the hinges for finishing the pieces.

There is enough distinction between the woods used in the design for the wood to be finished natural, to prevent trouble in staining. Apply one coat of thin shellac, allow it to dry; then two coats of good cabinet varnish, rubbed down between coats, will provide a good finish. For a rubbed finish, give a coat of rubbing varnish, allow it to dry at least 48 hours, then rub, in one direction, with fine pumice powder and rubbing oil on a thick felt, using a rubbing brush in the corners. Rub just enough to take the gloss off, wipe clean, and apply another coat. Rub this down as before, then repolish with rottenstone and oil.

If you want the walnut portions of the board darker than the natural finish, it will be necessary to go over all the inlaid bandings, the holly and the ebony with shellac, applied with a fine brush, and allow it to dry, so that the stain used on the walnut will not affect the other woods. After staining, apply a coat of shellac all over, allow this to dry, and then proceed with the varnishing as described above.

Guard for the Violin Bout

Proper bowing, when playing a violin, is an art acquired only after considerable practice. The greatest trouble lies in the student's inability to draw the bow at right angles to the strings. Failure to

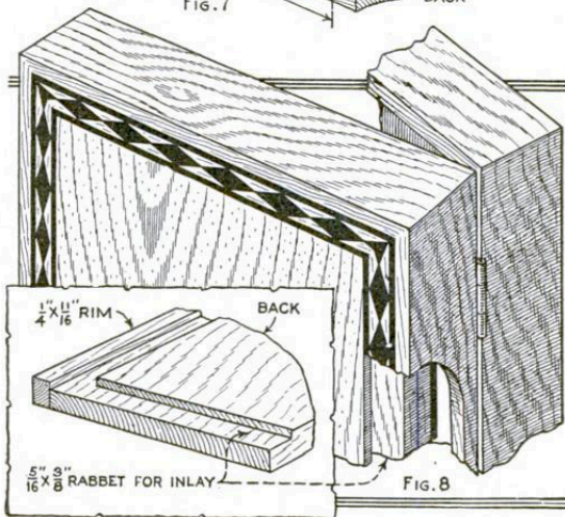
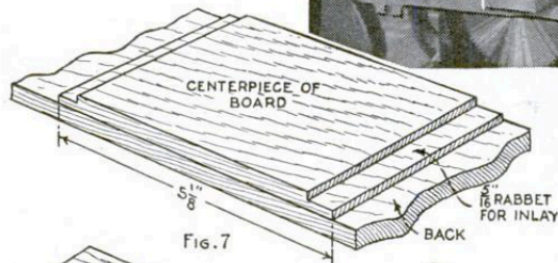

do this results in the bow striking the right bout of the violin instead of clearing it. The friction of the rosined bow hair leaves a deposit of rosin on the edge of the bout, which accumulates very rapidly with every misjudged stroke. In time, the edge of the bout becomes worn, begins to roughen and finally splinters. Besides

defacing the violin, the hair of the bow catches on the splintered edge, resulting in broken bow hair and an increased mutilation of the edge of the bout. A violin, at all valuable, should be protected against this abuse. A strip of adhesive tape, fastened to the edge of the bow, is the solution, and does not affect the tone of the instrument. When soiled, the tape is removed, and the edge of the bout cleaned with any of the preparations sold for cleaning stringed instruments. Do not steam the tape or apply hot water, as such practice will soon ruin the varnished surface.—Henry B. O'Connell, West Haven, Conn.

JANUARY

N.S.E.
25 CENTS

POPULAR MECHANICS

MAGAZINE

WRITTEN SO YOU CAN UNDERSTAND IT

REGD. TRADE MARK, GREAT BRITAIN, No. 410426

REG. U.S. PAT. OFF.



SEE PAGE 82