

THE
LAWNMOWER
SERVICE MANUAL

Price \$1.00

Copyrighted 1940 by

YARD-MAN, INC.
JACKSON · MICHIGAN

INDEX

	Page
Foreword	3
History	5
Design and Construction of the Silent Yard-Man	8
Mower Service Manual	
Your Shop; Shop Plans	12
Work Plans	13
Inspection of the Silent Yard-Man	14
Inspection and Preparation for Sharpening Conventional Type Mowers	15
Tests and Adjustments	16
Re-assembly	17
Cleaning	17
Reel Bearing Adjustment and Replacement for the Yard-Man	18
Adjustment	18
Replacement—Removing the Reel from Frame	18
Removing the End Plate	19
Installing Bearings	20
Re-assemble Chassis	21
Instructions for Operating a Yard-Man Cutter Bar Grinder	23-24
Grinding Reels with the Yard-Man Grinder	25
Foreword	25-26-27
Instructions for Mounting and Grinding	28-29-30
Summary	30
Grinding on Conventional Grinders	31
Yard-Man Cutter Bar Adjustment	32
Lapping	33-34
Vibration	35-36
Lapping Compound	36
Greasing	36-37
Replacement of Yard-Man Wheel Bearings and Axles	37
End Play in Wheels	38
Tires	38
Service Shop Equipment	
The Yard-Man Reel Grinder	40
Yard-Man Bed Knife Grinder	41
Yard-Man Lapping Stand	42
Lapping Compound	36 and 42
Silent Yard-Man Cutting Units	
Yard-Man Trailer Units	44
Hercules	45
Defiance	45
Ideal	45
Conco	46
Homelawn	46
Roberton Electric	47
Parts and Price List	47
	48

HISTORY

THERE is little doubt but that lawns are as old or older than civilization. Even the cave dwellers must have parked their Dinosaurs out front and come to know that, if the animals ate off the tops of the grass, the grass grew better and stayed green. Perhaps the first lawns were started that way, and thus began the instillation into man of an admiration for green fields that is so universal among the human race.

After the Dinosaurs came sheep and goats, which were somewhat better, too, because the wear and tear on the grass was not so much. It was not until the Greeks had invented the scythe, and put it into use, that grass really came into its own and became the thing of beauty and joy that is possible for it to be when properly grown and cut.

However, to cut a sizeable yard with the scythe and get a good job was no mean accomplishment. It took a lot of time. No one but a slave had that much time and, when the slaves gave out, men began looking around for something with which to do the job faster and with less labor.

EARLY DEVELOPMENTS

In the early 1800's came the development of the reaper, which was essentially a machine for cutting grass after grass had grown tall.

The first lawn mowers made, naturally, were of the sickle-bar type. While they were satisfactory for tall grass or grains, they weren't so good for short grass—so the inventors began looking around for something else. One inventor invented the whirling circular blade, like a circular saw, with the flat surface presented to the ground, the width of the swath equal to the diameter of the disc. He had a whetstone placed against the cutting edge of the disc to keep the edge sharp at all times.

FIRST PATENTS

The first patent issued from the patent office appears to be to Peter Galliard, a resident of Pennsylvania, in 1812, but it was forty-four years before Aultman & Miller applied for and obtained a patent upon a mower having two wheels, an adjustable cutter bar and revolving reel—all the essential parts of the present-day machine.

Of course, there were lots of new, trick designs brought out, but they seemed unable to catch on with the user public. Few of them contemplated giving the user more than a machine with one or two freakish attachments or some queer way of adjusting the cutting elements, while they were deplorably weak in the important parts like the reel, reel bearings or cutter design.

YEARS WITHOUT CHANGE

Thus, the industry ran on for years without much improvement, even though the manufacturing art had improved by leaps and bounds. One firm boasted in their catalogue that they had not changed the design for forty years; therefore, their users could surely get parts whenever they needed them.

In those forty years many things had happened to this country of ours—the automobile, the aeroplane, stream-liners, accounting machines, radio, telephones, rayon and a thousand other things came into common use, replacing machines and materials formerly used for the same thing prior to their conception.

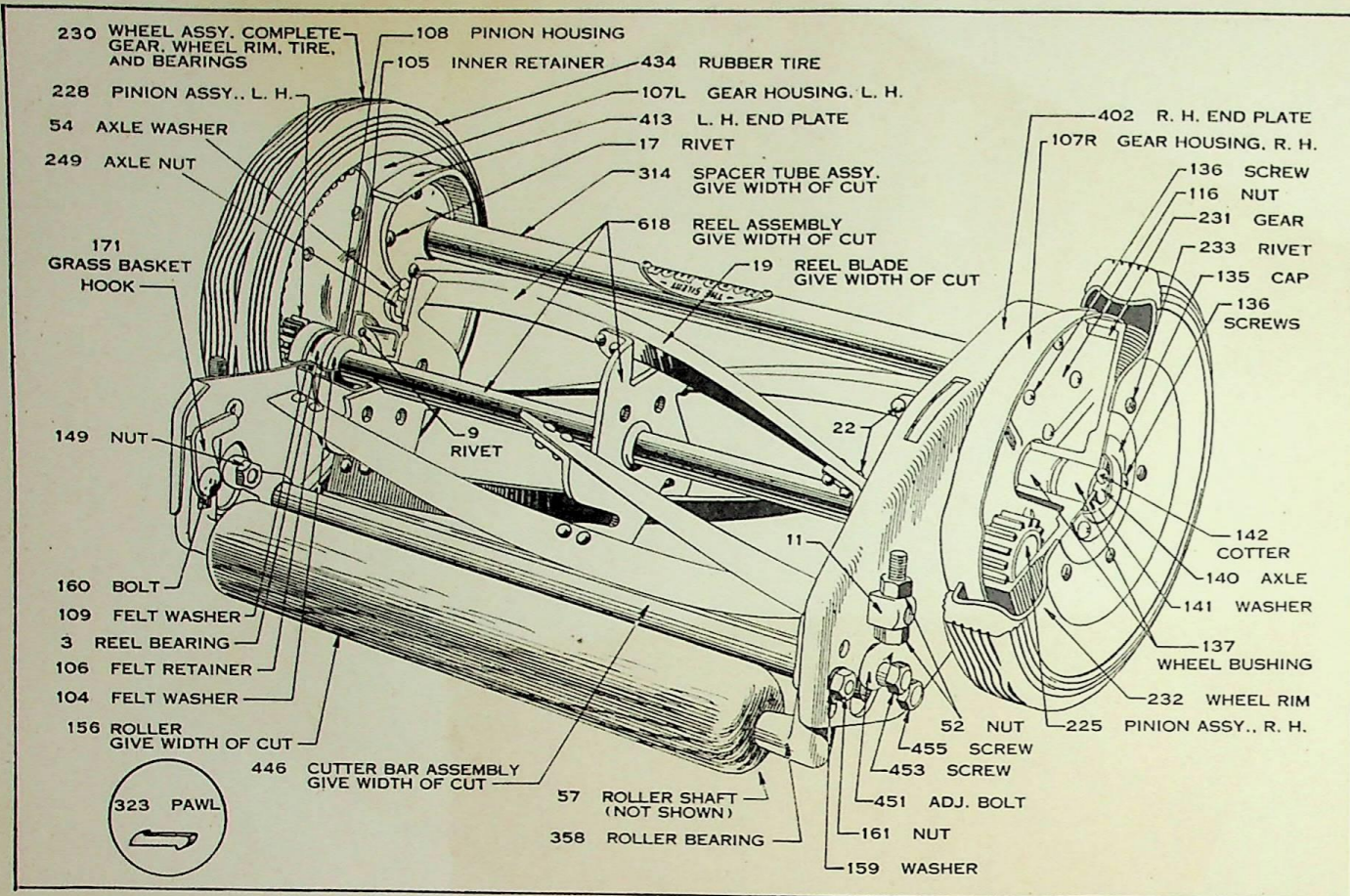

NOTE—IMPORTANT!

You may order parts for ALL MODELS of Silent Yard-Man Gear Driven mowers from THIS PARTS LIST if you follow these instructions:

1. Print the part number and name plainly.
2. State the Model Number which is on the shrub bar.
3. If no Model Number appears on a plate on the shrub bar STATE "NO MODEL NUMBER ON SHRUB BAR."

CAUTION: If the Model Number plate has been lost from shrub bar DO NOT USE THIS LIST. We MUST know the correct model.

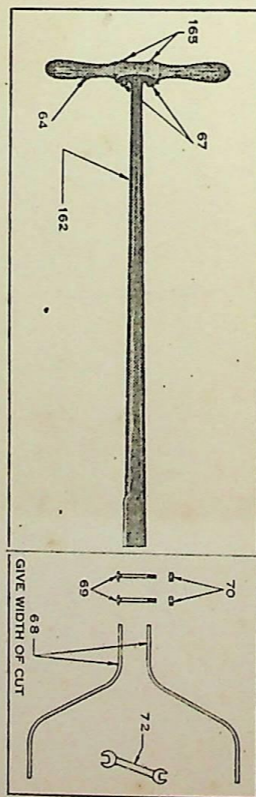

Part No.	Description	List Price	Part No.	Description	List Price
401-R	END PLATE ASSEMBLY—R. H.	\$3.50	136	Hub Cover, and Spacer Tube Flange Screws	\$.01
402	End Plate—R. H.	1.20	137	Drive Wheel Bearing	.15
3	Roller Bearing	1.25	139	DRIVE WHEEL AXLE ASSEMBLY	.40
104	Felt Washer	.08	140	Drive Wheel Axle	.30
105	Inner Retainer	.40	141	Drive Wheel Axle Washer	.05
106	Felt Retaining Washer	.15	142	Drive Wheel Axle Cotter Pin	.01
107-R	Gear Housing—R. H.	.60	149	Cutter Bar Jam Nut	.05
107-L	Gear Housing—L. H.	.60	249	Drive Wheel Axle Lock Nut	.05
108	Pinion Housing	.40	54	Drive Wheel Axle Spacer Washer	.05
9	Pinion Retainer Rivet	.01	446	CUTTER BAR ASSEMBLY—14"	1.75
10	Handle Bar Trunnion	.15		16"	2.00
11	Adjusting Screw Trunnion	.20		18"	2.30
412-L	END-PLATE ASSEMBLY—L. H.	3.50		21"	2.60
413	End Plate—L. H.	1.20	451	Cutter Bar Adjusting Screw	.20
314	SPACER TUBE ASSEMBLY—14"	.50	52	Adjusting Screw Nuts	.05
	16"	.60	453	Cutter Bar Clamp Screw—Rear	.20
	18"	.70	455	Cutter Bar Clamp Screw—Front	.20
	21"	.90	156	ROLLER ASSEMBLY—14"	.60
116	Spacer Tube Flange Nut—used with No. 136 screw	each .01		16"	.70
618	REEL ASSEMBLY—14"	5.50		18"	.80
	16"	7.00		21"	1.00
	18"	8.00	57	Roller Shaft	.10
19	Reel Blade—14"	.70	358	Roller Shaft Bearing	.25
	16"	.80	159	Roller Adjusting Bolt Washer	.02
	18"	.90	160	Roller Adjusting Bolt	.06
	21"	1.00	161	Roller Adjusting Bolt Nut	.02
22	Reel Blade Rivet	.01	162	HANDLE ASSEMBLY COMPLETE	1.50
323	Pawl	.10	163	Handle Shaft Assembly	1.20
225	PINION GEAR ASSEMBLY—R. H.	.50	64	Handle Grip	.30
228	PINION GEAR ASSEMBLY—L. H.	.50	165	Handle Grip Bolt	.06
230	DRIVE WHEEL ASSEMBLY	3.00	67	Handle Grip Bolt Nut	.02
231	Drive Wheel Gear	1.00	68	HANDLE SHAFT BRACES (Give width of cut)	.40
232	Drive Wheel Rim	1.00	69	Handle Shaft Brace Bolt	.10
233	Drive Wheel Rim Rivet	.01	70	Handle Shaft Brace Bolt Nut	.02
434	Ruber Tire	1.30	71	Grass Basket Hook	.10
135	Drive Wheel Hub Cover	.10	72	Wrench	.25
			91	Phillips Head Screw Driver	.15

DEMAY'S INC. JACKSON, MICH.

YARD-MAN

INCORPORATED

1410 WEST GANSON STREET
 JACKSON, MICHIGAN

set _____

address _____

Date _____

Dear Sir:

Your recent order for Yard-Man parts does not contain sufficient information to enable us to tell what you want. Fill out the following questionnaire and mail to us at once.

CHART OF PARTS FOR YARD-MAN MOWERS (OVER-ALL LENGTHS)

M - Model	Width of Cut	Length Reel Shaft	Cutter Bar and Spacer Tube	Roller Lengths, All Models (Less Pins)
M-38 <input type="checkbox"/>				
1936-37-38	14" -----	17 3/8" -----	14 5/8" -----	14" ----- 12 1/16"
No Anti-Winders	16" -----	19 1/2" -----	16 3/4" -----	16" ----- 14 3/16"
No Name Plate	18" -----	21 5/8" -----	18 7/8" -----	18" ----- 16 5/16"
No hole in spacer bar	21" -----	24 5/8" -----	21 7/8" -----	21" ----- 19 5/16"
M-39 <input type="checkbox"/>				
1939	14" -----	17 5/8" -----	14 7/8" -----	
Same as M-40	16" -----	19 3/4" -----	17 " -----	
Less Anti-winder	18" -----	21 1/4" -----	18 1/2" -----	
Use M-38	21" -----	24 3/8" -----	22 1/8" -----	
End Plates				
M-40 <input type="checkbox"/>				
1940	14" -----	17 5/8" -----	14 7/8" -----	
	16" -----	19 3/4" -----	17 " -----	
	18" -----	21 1/4" -----	19 1/2" -----	
	21" -----	24 3/8" -----	22 1/8" -----	
M-50 <input type="checkbox"/>				
1941-42	14" -----	17 5/8" -----	14 7/8" -----	
Same as M-40	16" -----	19 3/4" -----	17 " -----	
	18" -----	21 1/4" -----	18 1/2" -----	
	21" -----	24 3/8" -----	22 1/8" -----	
Craftsman <input type="checkbox"/> 1940				
Give No. 8160	16" -----	19 3/4" -----	17 " -----	
Die Cast End Plates	18" -----	21 1/4" -----	19 1/2" -----	
Craftsman M-80 <input type="checkbox"/>				
Give No. 8171	16" -----	19 3/4" -----	17 " -----	
End Plated as M-40 and M-50	18" -----	21 1/4" -----	19 1/2" -----	
Defiance <input type="checkbox"/> or Craftsman <input type="checkbox"/>				
Gasoline	8150 18" -----	21 1/4" -----	19 1/2" -----	
Electric	8153 18" -----	21 1/4" -----	19 1/2" -----	
Hercules 8151 <input type="checkbox"/>				
or Craftsman (Gasoline Driven)	21" -----	24 3/8" -----	22 1/8" -----	
Toro 1938 <input type="checkbox"/>				
No name plate or holes in spacer bar	18" -----	22 1/4" -----	19 1/2" -----	
	21" -----	25 1/2" -----	22 3/4" -----	
Toro 1940 <input type="checkbox"/>				
No name plate or holes in spacer bar	18" -----	22 1/4" -----	20 " -----	
	21" -----	25 3/4" -----	23 " -----	

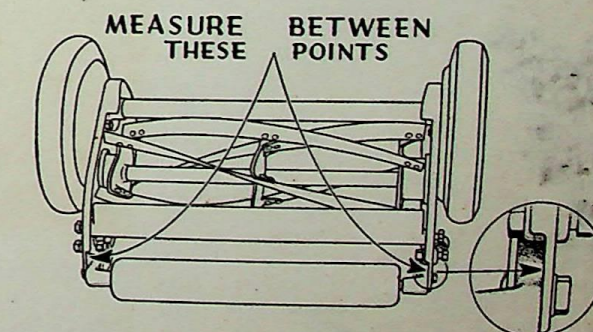
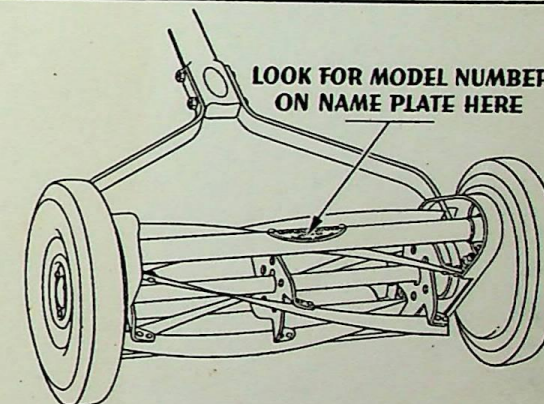

Remarks:

YARD-MAN, Inc.

CHECK WIDTH OF CUT AND OVER-ALL LENGTH OF PART DESIRED.

BUILDERS OF THE ORIGINAL SILENT YARD-MAN LAWN MOWER

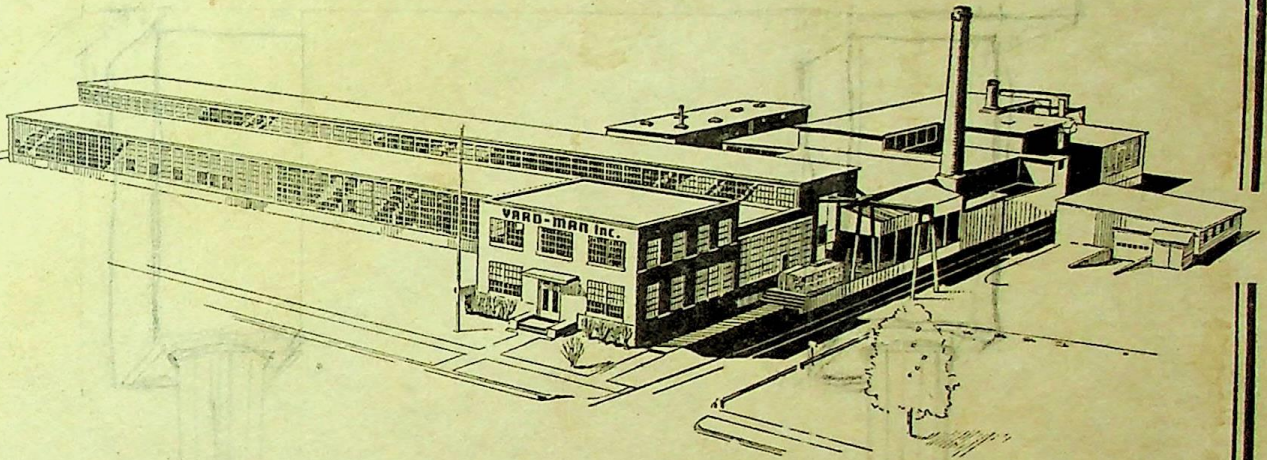

Our new location at 1410 West Ganson Street, Jackson, Michigan

*"You are cordially invited
to visit our plant at any
time."*

**T. B. Funk,
President**

