

*Bill
Photo*

GONSET

"Commander"

Model B

35-50 watt

MULTI-BAND TRANSMITTER



COMPANY

801 South Main Street, Burbank, California

GONSET "COMMANDER" TRANSMITTER
TECHNICAL SPECIFICATIONS

Model B

Type emission: Phone or c-w (including break-in).

Frequency range: 1700 kc. to 54 Mc. Included coils cover
3500 kc. to 30,000 kc. Plug-in final coils available
for balance of frequency range.

Frequency control: Fundamental crystals between 1.7 Mc. and
9 Mc. in 241/243 type holder (.094" dia. pins spaced
0.487"). Optional v-f-o attachment for operation on
10, 15, 20, and 75 meter phone bands available.

Tube line up: 6AG7 oscillator and buffer-multiplier; 6146 r-f
power amplifier; 12AT7 a-f amplifier; (2) 7C5 Class
AB-2 modulators.

Type modulation: High level plate-screen modulation. Integral
high level speech clipping.

Microphone input: Optional carbon or public address type crystal
or high impedance dynamic (approx. -50db) on PL-68 plug.
Gain adequate to permit 10 db of speech clipping at
normal voice level (close talking).

Power requirements: 6.3 volts a.c. or d.c. at 3.1 amp. and
300 volts d.c. at 200 ma. (phone) or 135 ma. (c-w).
Easily modified to run at 400-425 volts from surplus
PE-103 surplus dynamotor for intermittent amateur phone
operation. Easily modified for 12 Volt operation.

Antenna feed: Output circuit is designed to feed all conventional
feed lines, either two-wire balanced or coax, when operating
at moderate standing wave ratios, or to feed directly into a
resonant Marconi or loaded whip.

Size and weight: 5 3/8 in. high by 8 1/8 in. wide by 7 1/8 in. deep.
Weight 7 lbs.

GENERAL

The Gonset COMMANDER is a compact, general purpose transmitter for amateur or commercial applications. Efficient operation is provided on any frequency between 1.7 and 54 Mc. While designed primarily for mobile use, its compactness and neat appearance make it ideal for fixed station use in an apartment or any place space is at a premium.

Great care in design has been taken to provide a high ratio of carrier power to total transmitter input power, thus minimizing the drain on the car battery when the transmitter is employed for mobile work. All stages, both audio and r-f, are designed to run at 300 volts, thus conserving the power ordinarily wasted in dropping resistors when higher voltages are employed for the final amplifier and modulator. The use of a 6146 r-f power amplifier, designed for high efficiency when run at comparatively low voltage and high current, permits as much power output at 300 volts as is ordinarily obtained from an 807 at 400 volts or more. A slight modification of the COMMANDER permits use of a surplus PE-103 dynamotor for intermittent amateur operation on frequencies below 29.7 MC.

POWER SUPPLIES

The 300 volt dual vibrator packs listed are rated at 200 ma. for intermittent use such as transmitter service, and can be used satisfactorily up to 220 ma. for such service. They ordinarily come equipped with OZ4 rectifiers, which have the advantage of requiring no heater power in addition to having low voltage drop. Greater reliability of operation can be achieved at a slight sacrifice in output voltage by substituting 6AX5 or 6W5 rectifier tubes (preferably the latter because of their lower heater drain). The heaters should be wired so that they come on when the transmitter tube heaters are turned on. If the pack does not have a separate "hot" terminal for the heaters for optional use of such rectifiers, then the rectifier sockets should be so wired. A pair of selenium full-wave rectifiers make an ideal substitution except for expense.

COMMERCIAL 300 VOLT POWER SUPPLIES

suitable for use with Gonset "Commander"

Carter (dynamotors) type 320AS2, MAS320, or 320A

Harvey Wells (dynamotor) type DPS-5006

Mallory (dual vibrator pack) type 555-H

Cornell Dubilier (dual vibrator pack) type 6DRA6

Radiart (dual vibrator pack) type 454

NOTE

A 400 volt paper or 450 volt electrolytic capacitor of at least 2 mfd. should be connected across the output terminals of the above packs to prevent a-f from flowing in the dynamotor armature winding and to provide an a-f bypass for any hash filter inductors incorporated in the output leads of the vibrator packs.

When using a dynamotor, the send-receive relay should be provided with sufficient contacts that one pair may be used to disable the transmitter instantly when the push-to-talk switch is released. Otherwise the transmitter will remain on the air a second or so after the switch is released.

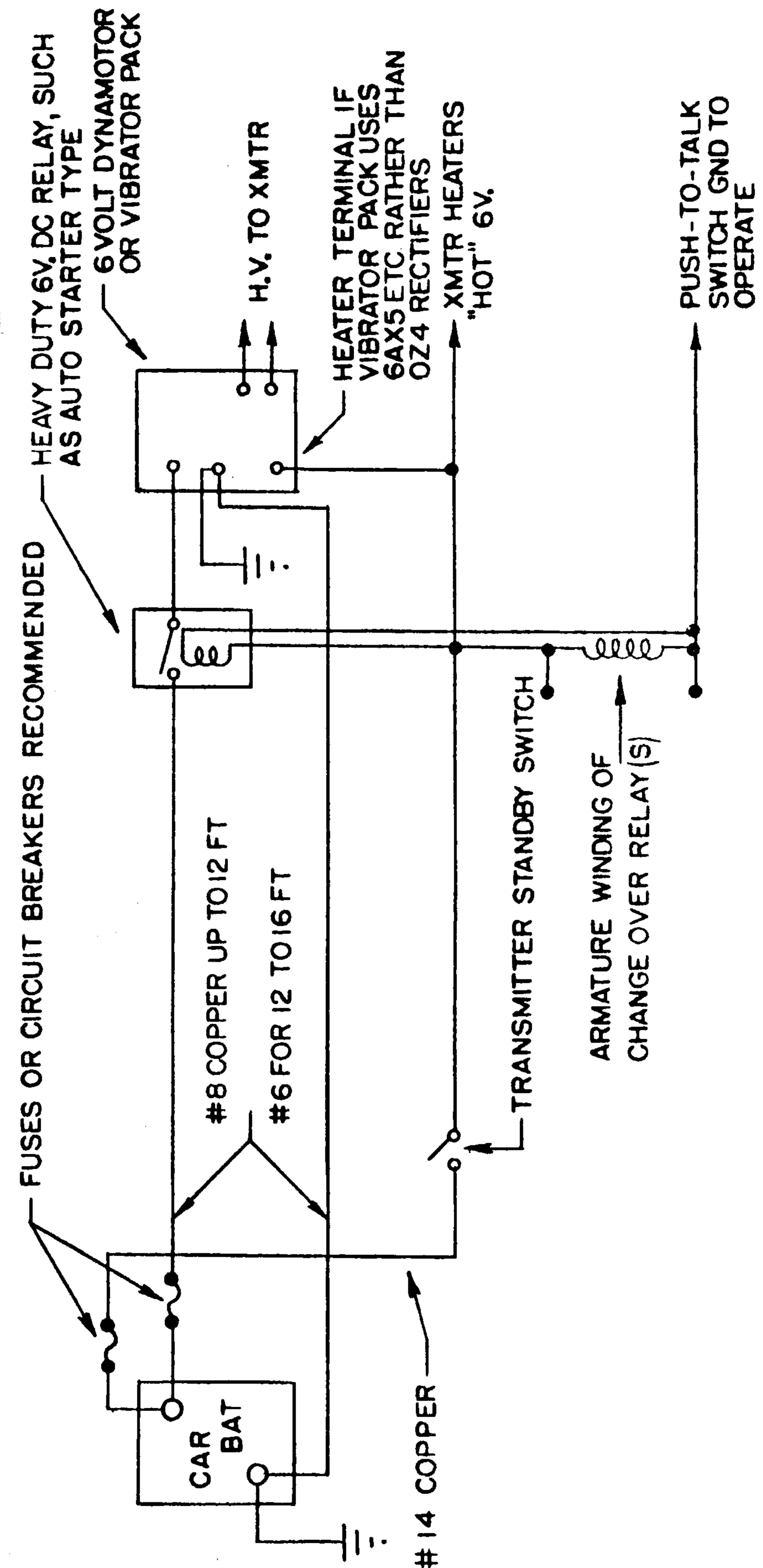

POWER AND CONTROL CIRCUITS

COIL DATA

for frequencies outside amateur bands

1700-2200 kc.	Use G-160 coil (available as accessory)
2200-2800 kc.	Use G-160 coil with padder removed
2800-3500 kc.	Remove padder and 8 turns from G-160
3500-7300 kc.	Use G-40/75/80 (furnished with transmitter). Note: For phone operation between 5000 and 7300 kc. remove 4 turns.
7300-10,000 kc.	Remove 7 turns from G-40/75/80
10-14 Mc.	Remove 9 turns from G-40/75/80
14-30 Mc.	Use G-10/15/20 (furnished with transmitter)
30-43 Mc.	Use G-10/15/20 with 2 turns removed
43-54 Mc.	Use G-6 coil (available as accessory)

Note: Amateur band calibrations on final tank coil tuning condenser apply only when correct coil is used, without modification.

MOUNTING DATA

The COMMANDER comes equipped with rubber feet for portable or fixed station operation. Two universal mounting brackets are furnished to facilitate vehicular mounting of the unit, permitting it to be either supported from below or hung from above, as shown in the accompanying illustration.

Because of the small amount of clearance inside the case on the side closest the coil door, it is important that the short screws furnished be inserted with the heads inside the cabinet. Four cap nuts are furnished to give a finished appearance when used on the outside of the cabinet. The four long screws are for fastening the brackets to the vehicle. Longer 8-32 bolts may be substituted if required for a particular mounting situation.

The brackets themselves may be used as templates when drilling the cabinet for the mounting screws. The brackets may be used turned either inward or outward, as desired.

When used in any late model full size passenger car, shock mounting is not required, and may actually be undesirable unless the shock mounts are "engineered" to the job.

When installing the mounting brackets, keep in mind that sufficient clearance should be left behind the cabinet to permit connecting the necessary wires, adjusting the gain control, removing the screws which hold the chassis in the cabinet, etc. When possible at least four inches clearance should be left behind the cabinet. Even this amount of clearance will require the use of a stubby or right angle screwdriver when removing or replacing the chassis in the cabinet.

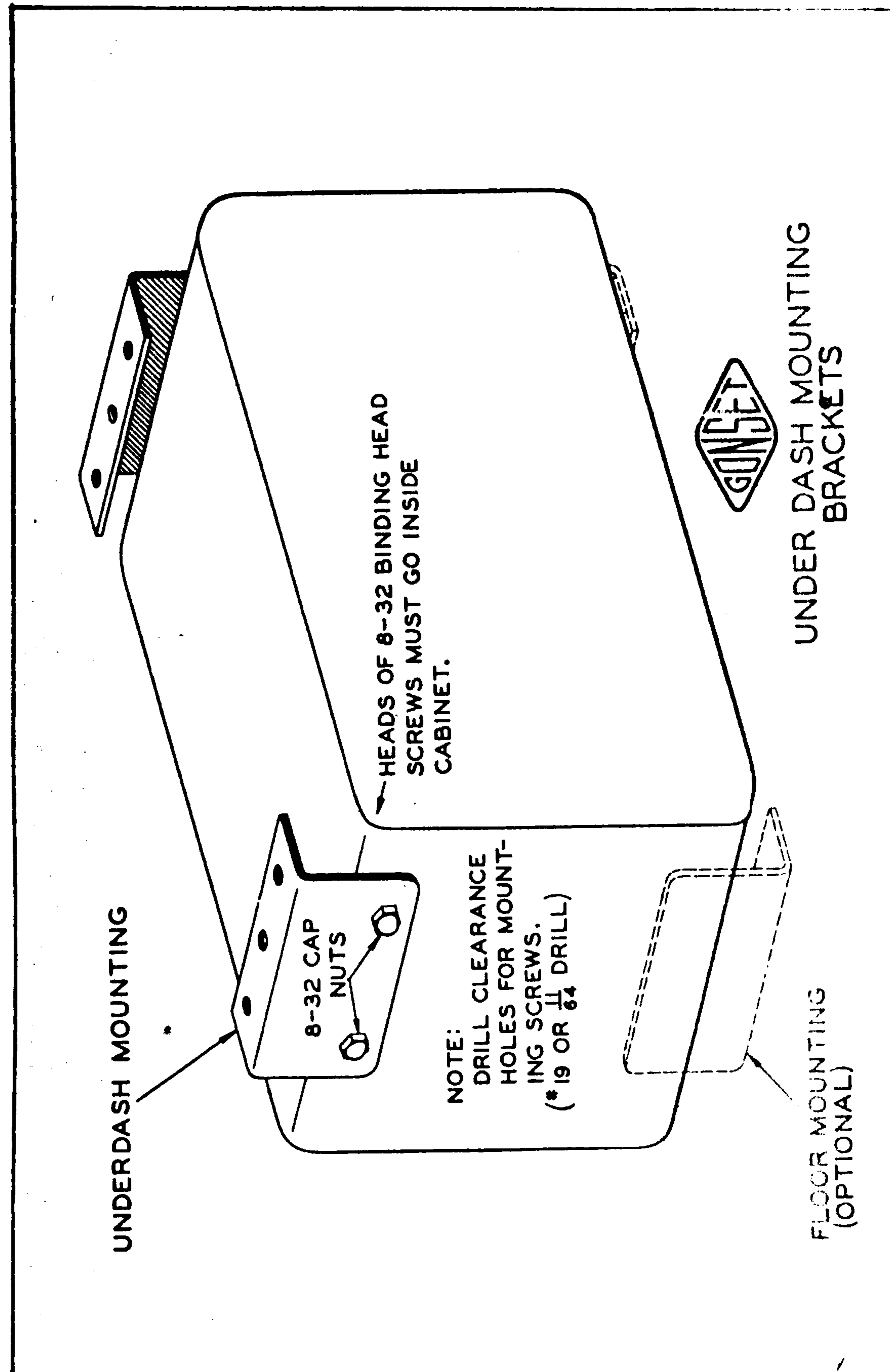

ANTENNAS AND COUPLING

When using modified coils for other than amateur operation, the correct tank circuit response should be checked initially with the aid of a calibrated absorption-type field strength meter or a grid dip meter, and the setting of the 0-100 logging scale noted for future reference.

The high efficiency output tank circuit and coupling method employed in the Gonset COMMANDER is somewhat unique among commercially manufactured transmitters, yet is at the same time perfectly straightforward. It permits proper coupling to virtually all efficient antenna systems. While unlike a pi-network it will not load into a "random length of wire" which happens to be of a suitable length, such an antenna is not especially efficient anyhow, and the method employed in the COMMANDER has the following advantages:

It is more effective in coupling into a very low impedance load, such as a loaded 75 meter whip which is resonant.

It can be used to couple into a balanced feed line (300 ohm ribbon, open wire line, etc.) without need for an external "balun" or line balance converter to prevent line unbalance.

The tank condenser setting remains substantially constant for all suitable loads, making it possible to calibrate the tank condenser dial for the various amateur bands and thus avoid the possibility of tuning up on an undesired harmonic.

The various possible coupling methods which may be employed with the COMMANDER are shown in the accompanying illustration. In every case it is assumed that the load presented by the antenna is not excessively reactive, which is desirable for good performance of the antenna and feed line anyhow. If the Marconi (including a loaded whip) is approximately resonant or the feed line does not have an excessive standing wave ratio, this condition will be met.

The arrangement shown at "A" is the simplest and is satisfactory for feeding coaxial lines above 14 Mc. or a mobile resonant whip on 75 meters. The small clip with pigtail is fastened to the lower Fahnstock clip on the coil base, and the coil clip run up and down the coil turns to vary the loading. As the top of the coil is the ground end, moving the clip down the coil increases the loading and vice versa. The Marconi antenna or the inner conductor of the coax is connected to the lower feed-through insulator on the rear of the cabinet and the outer conductor or ground to the ground binding post.

If desired the condenser C-1 may be inserted in series with the load as shown, the condenser being placed as close as practicable to the transmitter. Minor variations in loading, as may be required when changing frequency over an amateur band, then may be accomplished by adjustment of the condenser, making it unnecessary to move the coil clip after it is set to an optimum point. Any reactance introduced thereby is small and is automatically "tuned out" when the final tank condenser is resonated. As the r-f voltage developed across this condenser is low, an ordinary receiving type condenser may be employed.

The arrangement shown at "B" is comparable to that at "A" except that a link is wound around the coil and connected to the two Fahnstock clips on the base. The number of turns may be varied to accommodate a wide range of impedances. The greater the number of turns (up to a certain point), the greater the loading. Minor variations in loading may be accomplished by sliding the link along the coil, maximum coupling occurring when the link is midway between the ends of the coil. The link always should be kept between the center and the ground (top) end of the coil. This arrangement is slightly superior to that of "A" from the standpoint of minimizing spurious radiations, and ordinarily is to be preferred to that of "A" for fixed station use when other receivers are located very close by. The series variable condenser C-1 may be employed with the B arrangement if desired, its function being the same as that at "A".

The arrangement at "C" is employed with balanced feed lines such as 300 ohm ribbon, open wire "Gonset Line", etc. Line balance can be improved with this arrangement and capacity coupling to the feed line virtually eliminated by connecting a 20 mmfd. 5 per cent fixed ceramic capacitor from each terminal to

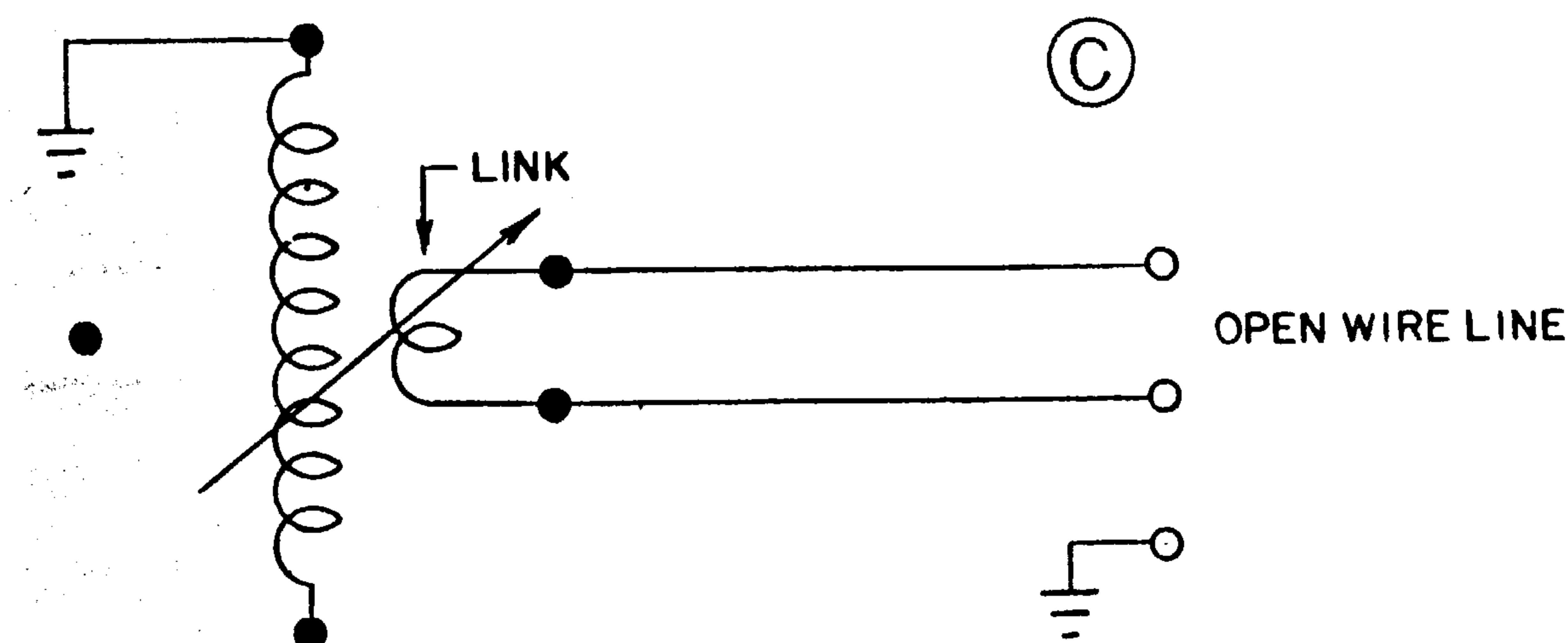
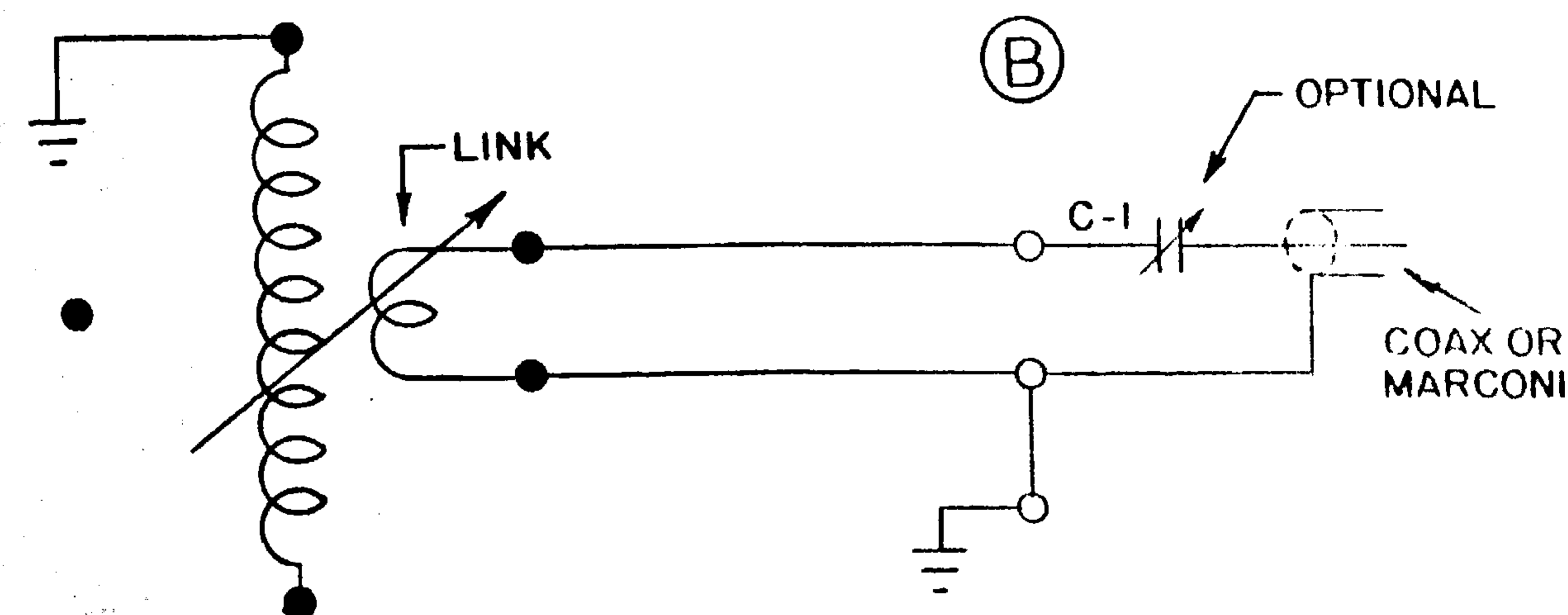
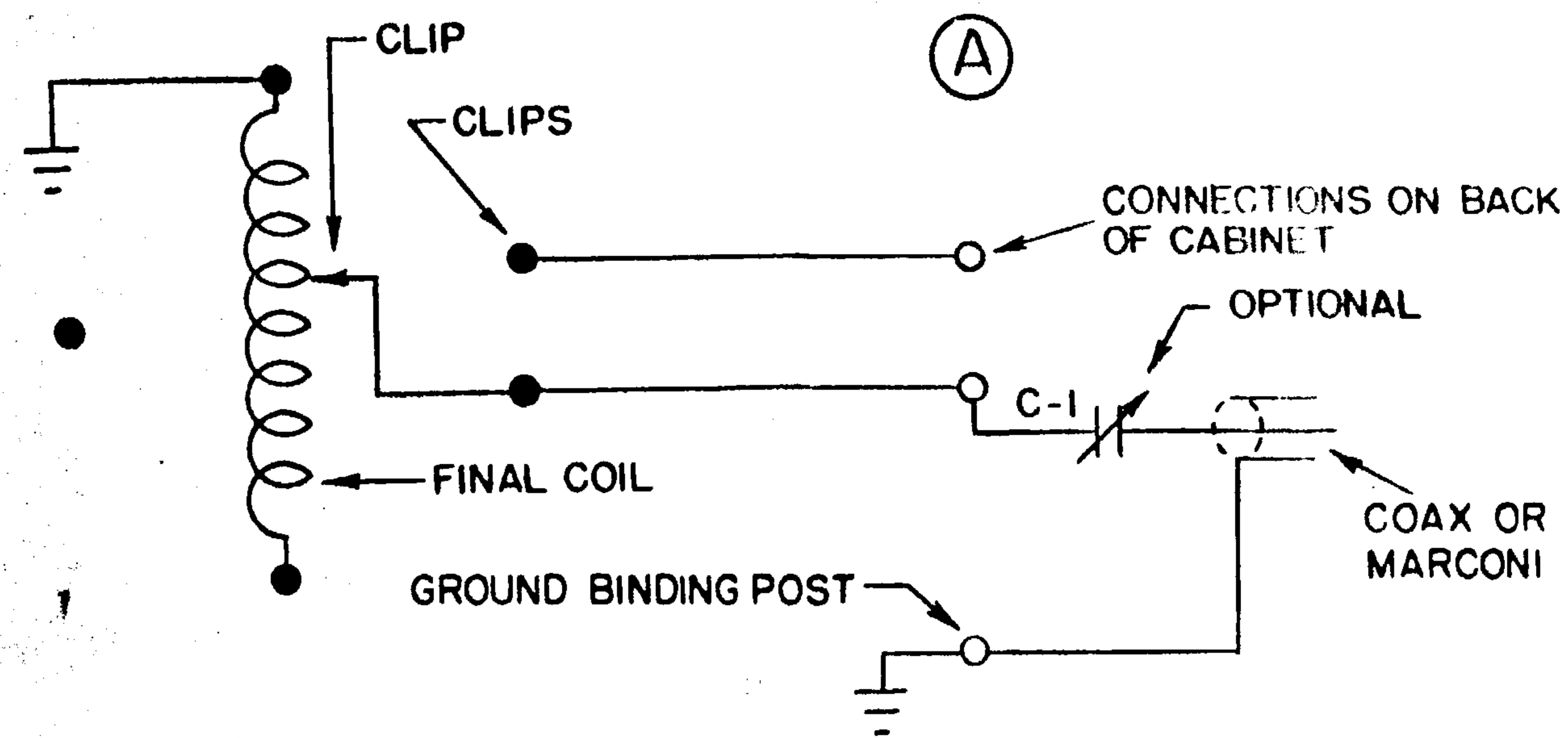

ANTENNA AND FEED LINE CONNECTIONS

In each case the five pins represent the front view of the coil socket or the pins of the coil base when inserted. Maximum capacity of variable condenser C-1 should be approximately 10 times the operating wavelength in meters.

the ground binding post, keeping the leads of equal length, and by keeping the link towards the ground (top) end of the coil.

POWER CONNECTIONS

Power connections are made via the Jones plug on the rear of the chassis. The cover shell is removed by knocking out the retainer pin. Connections are as follows:

- 1) Oscillator Cathode
- 2) P-A cathode
- 3) "Hot" 6.3 volts, a-c or d-c
- 4) Heater (6.3 volts) ground
- 5) B plus 300 volts
- 6) B plus 300 volts
- 7) Push-to-talk via mike switch
- 8) B minus ground
- 9 and 10) On-off switch on front panel
(max. 1 amp. 115 volts a-c or 4 amps.
at 6 volts d-c to be used as desired)

For phone operation both pin 1 and pin 2 should be jumpered to ground. No attempt should be made to obtain push-to-talk phone operation by opening the cathodes of the oscillator and/or p-a, as this would leave the modulator unloaded.

For 300 volt operation, both pin 5 and pin 6 should be connected to B plus by wiring a jumper between the two pins on the plug.

When using a PE-103 power supply, delivering 400 to 425 volts under load, the p-a screen resistor R-11 should be replaced by a 25,000 ohm 10 watt Sprague "Koolohm" resistor. B plus should be connected only to pin 5. An external 4000 ohm 10 watt resistor is connected between pins 5 and 6, or between B plus and pin 6, and a 2 mfd. 600 volt paper condenser is connected from pin 6 or the "low" side of the resistor to ground. The resistor drops the voltage to approximately 300 volts on the exciter, a-f amplifiers, modulator screens, etc., fed from pin 6, and the condenser serves as an audio bypass. Pin 5 feeds B plus to the p-a and modulator plates. Always leave the phone-c.w. switch on "Phone" when using a PE-103 and do not attempt to use above 30 Mc.

For c-w operation keying may be done in the final cathode (pin 2), or, with active crystals, in both oscillator and final cathodes (pins 1 and 2) for break in operation. For p-a keying only, pin 1 is grounded and the key placed between pin 2 and ground. For break-in keying pin 1 is tied to pin 2 instead of grounded.

TUNE-UP PROCEDURE (PHONE)

Turn on heater voltage. Throw phone-c.w. switch to "Phone", tune-operate switch to "Tune", crystal-v.f.o. switch to appropriate position, and meter switch to "I-g" (grid current). Correct crystal or v-f-o frequency may be determined from the chart on the inside of the coil access door. Throw mike switch on rear of cabinet to correspond to type microphone, then plug in microphone. Set exciter band switch to correct range position (to hit 1, 2, or 3 times crystal frequency, as required). Press or throw transmit-receive switch and tune the p-a grid tuning condenser for maximum grid current.

It may be possible to obtain grid current at two settings, in which case the correct setting can be determined by the frequency coverage marked on the exciter band switch and the relative position of the grid tuning condenser.

After resonating the grid condenser, adjust the "Drive" switch to whichever position gives the closest reading to 2.5 ma. unless the p-a is used as a frequency doubler (as on 6 and 10 meters). On the latter two bands always throw the "Drive" switch to the "Hi" position.

Making sure the correct p-a plate coil is inserted, throw the Tune-Operate switch to "Opr", the meter switch to "I-p" (plate current), and quickly "dip" the p-a plate tank condenser to the dip closest the designated band on the dial scale, first loosening the dial lock if necessary.

NEVER THROW THE TUNE-OPERATE SWITCH TO "OPR" UNLESS A GRID CURRENT READING IS FIRST OBTAINED, AND NEVER ALLOW THE FINAL TANK CIRCUIT TO BE DETUNED FOR MORE THAN 3 OR 4 SECONDS WITH THE SWITCH IN THE "OPR" POSITION. Failure to observe these precautions may damage the 6146 tube.

Starting with very light loading, the loading is increased a little at a time until the plate current dips to approximately 100 ma. While it is possible to load the p-a up to considerably more input than this, the output goes up so slightly with heavier loading that there is no point in it. From the standpoint of tube life, modulation linearity, and battery drain the optimum load is that which causes approximately 100 ma. to flow at resonance.

Use of very high bias on a beam tetrode having high transconductance permits an efficiency when doubling to 6 or 10 meters which very closely approaches that obtainable when working "straight through", with the advantage of saving one multiplier stage and preventing a tendency towards self-oscillation often encountered on these frequencies when working straight through. Overall transmitter efficiency (based on total power drain) is higher than if an additional stage were incorporated to permit working the p-a as a straight amplifier on the 6 and 10 meter bands.

The first time a crystal is used, it is advisable to actuate the transmit-receive switch several times with the meter switch on "I-g" as a check to see if the grid current flows instantly. If it does not, the crystal is sluggish or has poor activity, and should be discarded. This is especially important with 160 meter crystals.

The transmitter is now ready to modulate, and the gain control on the rear of the cabinet should be adjusted to a level appropriate to the microphone and distance held from the mouth. The modulation level is correct when the plate current kicks slightly on vowel sounds. A downward fluctuation is not a sign of "downward modulation" or "carrier shift", but rather is caused by the fact that the modulator plate current kicks up somewhat on modulation peaks, causing the d-c plate voltage (and therefore the d-c plate current to the modulated stage) to drop slightly as a function of power supply regulation.

The modulator is so designed as to clip at a level just under 100 per cent, thus preventing negative peak clipping in the modulated amplifier even when the gain is increased to a level which ordinarily would produce bad negative peak clipping. The leakage reactance of the modulation transformer together with C-25 form a low pass filter which minimizes the bandwidth of the distortion components generated in the modulator as a result of clipping. Thus the gain may be increased to the point where distortion actually affects intelligibility, without objectionable sideband "splatter" being produced. This system of speech clipping requires no adjustment, and is highly effective in permitting heavy modulation without splatter.

When using a crystal microphone, a good ground is required, both to prevent "grid hum" in the first a-f stage and, at the higher frequencies, may be required in order to prevent r-f feedback. In a vehicular installation the car body makes a good ground, though it is important that the shield on the microphone cable be grounded only at the microphone jack.

A water pipe ground makes an excellent a-f ground for a fixed station installation, and also makes a good r-f ground for a 160 meter Marconi if the ground lead is not too long and heavy wire is used.

Above about 14 Mc. It is often difficult to obtain an effective r-f ground in a fixed station installation, and "a-f via r-f" feedback may occur when the gain control is advanced with a crystal or dynamic microphone. If this happens, a heavy wire or strap should be run to the closest large metal object, in addition to the water pipe ground. If this is not effective, then connect to the ground binding post, in addition to the water pipe ground, a "counterpoise" of wire slightly less than $1/4$ wavelength at the operating frequency. Very little r-f will flow in this wire, but it usually is effective in making the cabinet "stone cold" as regards r-f potential. The counterpoise should be run in a straight line in so far as practicable. It need not be insulated from wood furniture, etc., but should not be allowed to touch metal objects.

Do not under any circumstances attempt to obtain push-to-talk phone operation by opening the cathodes of the r-f stages, as this leaves the modulator unloaded but still working, with the possibility of extremely high peak voltages being developed.

It also is advisable never to permit the microphone switch to be on or thrown to "carbon" while a crystal microphone is inserted, as the microphone might possibly be damaged as a result of d-c voltage impressed upon it, though no damage occurred to any of several crystal microphones deliberately subjected to this abuse.

TUNE UP PROCEDURE (C-W)

For c-w operation the cathode of the p-a stage may be keyed, or, if a crystal having good activity is employed, both oscillator and p-a may be cathode keyed to provide break-in operation. No attempt should be made to key only the oscillator, as no protective bias is provided on the p-a and the 6146 will over-heat when excitation is removed.

For p-a keying, terminal 2 of the power plug is connected to the key, the other terminal of which is grounded. For break-in operation, terminals 1 and 2 are both connected to one side of the key.

The tune up procedure is the same as for phone except that the phone/c-w switch is thrown to "C-W" and references to the microphone, gain control, etc. are ignored.

Unless the key leads are kept short, a .005 mfd. mica or disc ceramic condenser should be connected directly across the key terminals to prevent the slight spark at the key contacts from producing key clicks in nearby receivers.

OPERATION OF P-A AS A STRAIGHT AMPLIFIER ON 10 METERS

A slight increase in output may be obtained on 10 meters for the same input by making some minor modifications, but when this is done the v-f-o attachment cannot be used for 10 meter operation.

A 27,000 or 33,000 ohm 10 per cent tolerance, metalized type 2 watt resistor should be substituted for grid leak resistor R-7. If necessary, spread the turns on the small coil L-3 in order to permit hitting fundamental resonance (up to 29.7 Mc.) on the grid tuning condenser with the band switch on the 15-27 Mc. position. Approximately 2 ma. of grid current will be obtained at normal plate voltage. This can be increased to about 2.5 ma. by substituting a 9.5 Mc. crystal and tripling.

REPLACEMENT OF 7C5's

When running under the conditions existing in the Commander, it is desirable that the 7C5 modulator tubes be reasonably well balanced. To check plate current individually, as when replacing tubes, connect a 0-50 or 0-100 ma. d-c meter from terminal 2 on the modulation transformer first to no. 1 and then no. 3. The resting currents should match within about 10 per cent. (The d-c resistance of the winding is much higher than that of the meter shunted across it.)



CHANGE TO 25K-10W.
FOR PE-103 OR
425-450 V. SUPPLY.

8K 1/1
6146E
(100mA Ip)

- OSC. CATHODE ①
- P.A. CATHODE ②
- HEATER "HOT" ③
- B- GROUND ④
- JUMPER FOR B+ ⑤
- B+ ⑥
- PUSH-TO-TALK VIA MIC. JACK ⑦
- HEATER GND. ⑧
- EXT. SWITCH ⑨
- EXT. SWITCH ⑩

6AG7 6146 12AT7 7C5 7C5

