

# INSTRUCTIONS

## MK-1 Programmable Keyer

*Autek Research*

### Contents:

1. Unpacking
2. Automatic Keyer Operation
3. Memory Operation
4. Connection to Transmitter
5. Battery Operation
6. Memory Programming Tips
7. In Case of Trouble
8. Warranty & Returns to Manufacturer
9. Late Notes--Covers Points Raised by Users
10. Schematics & Layout Drawing

### 1. UNPACKING

Carefully unpack the keyer. Note that various plugs, etc. are provided for hookup to a paddle, your transmitter, and a battery.

### 2. AUTOMATIC KEYSER OPERATION

You must first attach a paddle to the keyer. A dual-lever (squeeze) paddle is recommended to take advantage of Iambic operation, although a single lever paddle (with dot AND dash contacts) may be used. An old-fashioned hand key will not work, since it has only one set of contacts.

Connect the paddle to the large "stereo" plug enclosed. The common (ground or center) paddle output must go to the ground lead of the stereo plug. Dot and dash paddle outputs go to the other two plug connections. Plug the paddle into the keyer rear panel, and plug the keyer into a standard 115 VAC U.S. wall plug. Set controls as follows:

- Volume- **7/8** rotated
- Speed- 1/2 rotated
- Repeat- Down
- Combine C/D-- Down
- Record/Play-- Play

WHEN POWER IS FIRST APPLIED TO THE KEYSER, THE MONITOR MAY COME ON CONTINUOUSLY OR BE ERRATIC. THIS IS CAUSED BY AN UNCERTAIN INITIAL STATE OF ONE FLIP-FLOP, AND IS CURED BY SENDING A FEW DOTS AND DASHES TO INITIALIZE THE LOGIC.

Start sending with the paddle. Speed is adjustable from below 10 WPM to above 50 WPM. The highest speeds are impractical for sending, but will help when recording (see below). Note that the speed control is not linear; more-rapid speed change occurs at high speeds. Monitor tone may be adjusted by turning the trimpot on the keyer circuit board. (See layout drawing)

Closing the dash paddle yields a continuous string of dashes with a space in-between, and a perfect 3:1 ratio between dash and space length. Similarly, the dot paddle yields dots and spaces in a perfect 1:1 ratio.

At this point, be sure your paddle is connected with the proper sense. When you move your hand to the left, dashes should be produced; moving the hand right should produce dots. Reverse the dot and dash wires to the paddle if the opposite occurs. This sets your keyer up in the way used by virtually all CW operators.

**DOT AND DASH MEMORIES:** These memories may be demonstrated as follows: Set the keyer to its slowest speed. Select "Play". Quickly close first the dash lever then the dot lever. Quickly release both levers before the dash is over. Note that the keyer still supplies a dot. In fact, the dot lever may be tapped anytime during a dash or the following space, and the keyer will supply a perfectly-spaced dash/dot pair. The dash memory can be demonstrated analogous to the above by tapping the dot then dash levers. These memories greatly ease sending, even though you're normally not aware they're present.

**TRIGGERED CLOCK:** Note that a dot or dash starts immediately when the dot or dash lever is tapped (except when recording). This is due to a triggered internal clock time base that starts immediately on first paddle closure.

**IAMBIC OPERATION:** This feature may be demonstrated if you have a double-lever (squeeze) paddle. If both paddle contacts are closed (squeezed), the keyer puts out alternate dots and dashes, with the first contact closed determining whether a dot or dash occurs first. With the Iambic feature, the letters C, F, K, L, R, Y, and Q, as well as AR, may be sent with fewer finger motions. For example, to send an "F", hold the dot lever closed during the entire letter, but, in addition, tap the dash lever during the second dot. (Release the dot lever after the last dot starts) This is easier than removing your finger from the dot paddle during the dash, and replacing it for the last dot. For a "Q", reverse the procedure by holding the dash paddle and tapping the dot paddle during the second dash. The Iambic method may take some practice if you're used to a different technique, but it's worth learning. Enlist the aid of a local "advanced" CW operator to help you learn the easiest way to send each letter. Develop good habits early.

If you've never used anything but a straight key, it will take several hours to become accustomed to a paddle keyer. Practice off the air by sending the alphabet and concentrating on "problem" letters.

**SPEED CALIBRATION:** Exact speeds cannot be printed on the panel because of normal component tolerances. If you wish to calibrate the speed control, use the formula:

$$\text{Speed (WPM)} = \text{number of dashes in a 4.8 second period}$$

An equivalent, but easier, method is to measure the time, T, required to readout or record ONE memory section. (The time that the memory light stays on.) The formula is:

$$\text{Speed (WPM)} = 307.2/T$$

For example, at 20 WPM, one memory section will hold T= 15.36 seconds of data.

**TUNE:** Turning the speed control full counter-clockwise turns on your transmitter continuously for tuning.

### 3. MEMORY OPERATION

Set the controls as above. Be sure "play" is selected. Tap one of the message buttons (A, B, C, or D). Note that the light comes on, indicating recording or playing of the memory. Since no message is yet programmed, gibberish will be sent by the MK-1.

**RECORDING:** Set the speed control low. Turn the record/play switch to record. Nothing will happen until you tap one of the message buttons. Tap one button, then immediately start sending a short message. As long as the light is lit, your message is being recorded into memory. If it goes out before you have finished, your message is too long. After a short message, wait until the light goes out to ensure that old data is recorded over. Turning the speed control to top speed momentarily after finishing a short message will shorten the waiting time.

When recording, the internal clock runs continuously to allow spaces of any length to be entered into memory. Thus, there is a random delay between zero and the length of one dot between INITIAL lever closure and start of a dot or dash. This requires you to

synchronize your sending with the keyer to some extent. At slow (10-15 WPM) speeds, dots may even be missed occasionally. Use a hard "fist" at slow speeds. Don't release the dot lever until a dot starts. At higher speeds (25+ WPM), you may not notice the difference when recording, except that mistakes may be more frequent until you develop some proficiency. The clock is triggered at all times when the memory light is out, i.e. in normal sending.

**PLAYING:** BE SURE TO SET THE SWITCH TO "PLAY" BEFORE TAPPING A BUTTON TO AVOID ERASING WHAT YOU'VE RECORDED. Tap the same button to playback the message. Note that if you tap the button again while playing (or recording) the message will immediately start again at the beginning. This is handy if you hit the wrong button, or wish to repeat the first part of a message. At this point, record a message in each memory section.

**REPEAT SWITCH:** Select "repeat" and "play", and tap one of the buttons. Note that the message will repeat forever, including any space at the end of the message. Stop the message at the end by switching repeat "off", or stop it immediately by tapping the reset button or the paddle. "Repeat" has no effect when recording.

**COMBINE C/D SWITCH:** Set this switch to "combine". Tap the "C" button. The "C" message will play out, including any space, followed by the "D" message. If repeat is also set, the sequence will be "C D C D" etc. This switch operates in record also, allowing one continuous message (approx. 50 characters) to be recorded.

**EDITING:** If you make a mistake while recording, tap the same message button again and resend the message. Or, if you make a mistake near the end, you can save the earlier part by selecting "play" and starting memory readout. Just before reaching the mistake, flip the switch to "record" and complete sending the message.

**RESET:** Tapping the reset button stops any recording or playing in progress. Tapping or sending with the paddle while playing also resets the memory and instantly returns the keyer to paddle control. Sending with the paddle is very useful to add to the end of a message or to terminate a recorded message early & fill in the

#### 4. CONNECTION TO TRANSMITTER

Your MK-1 will directly key all popular ham gear, made since 1963, with the exception of some Ten-Tec gear, and, early models at least, of the FT-301D. (See Section 9: "late notes" for 301 and Ten-Tec). Please do not write and ask if the MK-1 will key your rig. There is no danger of destroying anything except with old, high power, cathode keyed rigs, which may possibly need a relay. Determine

this yourself. Keyer output transistor ratings are: +300 volts maximum, including any spikes, -15 ma maximum for negative (grid-block) key lines, +200 ma maximum for positive (cathode-keyed) key lines. These are voltages measured at the KEY. (Note: Plate current and voltage is typically much higher than values at the key. This should cause no concern). If in doubt about an older, or unusual rig, measure the voltage across the key line; then connect a milliammeter across the key line and measure the key current.

Both voltage and current should be within the range above. Also, one side of the key line must be grounded to the chassis. If these conditions are not met, you will have to obtain a relay. Connect one end of the relay to the MK-1 keyed output, and the other end to a power source equal to the relay voltage rating, e.g. 12V or 5V. A reed relay is recommended for high speeds. AGAIN IT IS STRESSED THAT OVER 99% OF RIGS IN USE DO NOT REQUIRE A RELAY, and can utilize the benefit of silent operation of the MK-1 output transistors.

**CONNECTION:** Connect the grounded end of the MK-1 phono jack on the rear panel to the grounded end of your transmitter key line, and the inside lead of the phono jack to the "hot" key line. If you reverse this connection, the MK-1 chassis will be "hot", and this may lead to RF pickup, and intermittent operation.

#### 5. BATTERY OPERATION

The rear-panel miniature phone jack accepts +9 to +14 VDC as from a battery. No power is drawn from the battery (13V. or less) unless AC power is interrupted, or the MK-1 is turned "off". When AC power is interrupted, the MK-1 instantly transfers to any battery connected to the rear panel. Current drain is typically 40 to 60 ma. at 9 volts, or 75-95 ma. at 12 volts. (Low monitor volume.)

A 9 v. common "transistor radio" battery is not recommended for continuous battery operation, since this type of battery will run down severely in a few hours.

However, this type of battery is sufficient to prevent loss of recorded messages caused by occasional AC power dropouts; e.g. as might occur in Field Day or other portable AC operation. For CONTINUOUS battery operation, a larger, 12 volt, power pack, such as eight 1.5 V "C" batteries in series, is recommended.

Where 220 VAC is the only power source, obtain an inexpensive 9-12 V. battery eliminator locally. This is the easiest way to power the MK-1 from 220 VAC.

The battery input is protected from reversed polarity.

#### 6. MEMORY PROGRAMMING TIPS

Some of the many ways to use the memory are:

**REPEATED CONTINUOUS CQ:** Program one memory to send "CQ CQ...DE (your call-once or twice)". With proper choice of number of CQ's, and "fine-adjustment" with length of spaces, you can make the CQ completely fill the memory, with no excessive space at the end. Play out using the repeat switch to send the CQ as long as desired. End the CQ by sending "K" with the paddle.

**CQ WITH AUTOMATIC PAUSE:** Similar to above, except add "K" at the end of the recorded message, and leave a several-second listening space at the end. During this pause in the recorded message, you can listen for an answer. If there is no answer, the keyer automatically repeats the CQ. With breakin, or semi-breakin rigs, you can wander about the room while the keyer does all the work, sending as many CQ/pause sequences as required for an answer. Stop the automatic sequence by switching off repeat, or by using the reset button or paddle. You will probably want to use the combine C/D function to get a long CQ/pause sequence, except perhaps in contests where shorter CQ's are appropriate.

**MANUAL CONTROL OF CQ LENGTH:** Let's say you record:

"CQ CQ..DE (your call) K". When playing the message out, you can lengthen the CQ by pushing the message button again just before "K" is sent. The message then starts at the beginning again. This feature may also be used to repeat the first part of ANY message, e.g. the signal report in contests.

**CONTESTS:** Many of the top contest operators use a programmable keyer such as the MK-1. Listen to them to learn the best ways to program your messages. As an example, the following is a possible recorded message sequence for the CQ WW DX contest:

Message A: CQ TEST DE (YOUR CALL TWICE) K  
Message B: 5NN (YOUR ZONE) BK  
Message C: R QRZ DE (YOUR CALL) K  
Message D: DE (YOUR CALL TWICE) K

These messages handle most sending except for the other stations call. Message "A" could be sized to just fit into memory so you could use the "repeat" switch when you leave the operating position for a few seconds. In this case, you might want to send the "K" manually, rather than recording it.

**USE OF FULL MEMORY IN EVERYDAY OPERATION:** The messages will hold virtually all standard CW exchanges, such as name, QTH, RIG, etc. If you use the combine C/D switch for a CQ and pause, you can record a portion of personal data in "A" and the remainder in "B".

**OTHER TIPS FOR GETTING ANSWERS:** Contest winners make most QSO's calling CQ, not by calling others. Your MK-1, once correctly programmed, will send flawless and businesslike CQ's at high speed, which greatly increases the tendency of other operators to call you in contests, or in everyday operation. You'll find that your keyer is as good as adding 6 dB in antenna gain or increased power simply because of this factor! Most MK-1 owners wonder how they ever got along without the memory once they use it a few days.

#### 7. IN CASE OF TROUBLE

Keyer trouble can occur in one of two distinct categories:

1. Keyer does not work properly when received.
2. Keyer fails after use for sometime.

In the first category, we find that many keyers returned immediately after receipt and operating properly. Usually, the owner has not connected the equipment properly or does not understand its use.

**READ THE INSTRUCTIONS AGAIN CAREFULLY AND CHECK ALL CONNECTIONS TO YOUR RIG AND PADDLE BEFORE ASSUMING THERE IS A DEFECT.**

Although we perform several tests and inspections before shipment, some keyers fail in the mail, usually

due to vibration which shakes loose a wire or intermittent solder joint. A careful physical inspection may turn up the difficulty and save a return. Push-down on all IC's to be sure they're firmly seated in their sockets.

The keyer is a complex device, and we do not recommend you attempt to service it yourself. However, if you do, be sure that AC power is disconnected and observe precautions required for CMOS circuitry: CMOS CIRCUITRY IS SOMEWHAT SENSITIVE TO BURNOUT BY STATIC CHARGES AND EXCESS VOLTAGES. In normal use, this is no problem. Also, simply reaching inside the unit or examining the circuit board should not cause failures. However, the following precautions should be observed for safety: 1) Work in a static-free environment. Nylon rugs, etc. can cause static sparks to build up on your fingers, which may be transferred to any IC that is touched. A wooden or concrete floor in the working area is best. 2) Always remove power before working on the board or removing or inserting any IC's. 3) Ground your soldering iron tip to the chassis or board ground using a cliplead before doing any soldering.

#### TROUBLE CHART

PROBLEM	POSSIBLE CAUSE/SOLUTION
Keyer sometimes stays on continuously when power is first applied.	Normal. Send a few dots or dashes to clear.
Wavering monitor tone or erratic operation on battery power.	Weak battery. Use 12 volts or ignore symptoms.
Keyer works OK but becomes erratic when transmitter is keyed. Or else, transmitter plate current is much higher than normal when using keyer. (Problem is RF pickup setting into keyer.)	Polarity of transmitter keying output may be reversed. Be sure MK-1 case and transmitter case grounds are connected together. (via MK-1 "key jack" output plug on rear panel) Connect .01 uf. disc bypass capacitors at paddle. One between dot and common, other between dash and common. In extreme cases, it may be necessary to shield leads to paddle, and ground the shield. Connect .01 uf bypass capacitor across transmitter key jack at transmitter.
Keyer seems to miss dots when recording.	Clock is not triggered when recording. Use a heavier "fist" when recording. See instructions above.
Other problems	See last section of instructions for any latest information.
Switch intermittent	Check switch with ohmmeter.

#### 3. WARRANTY & RETURNS TO MANUFACTURER

Read "in case of trouble" section before returning. Be sure to enclose a detailed description of symptoms inside the package, including name and address, rig model and type, and connections made to rig and paddle. If you don't include sufficient details we may not be able to help you, and you may receive back the unit in the same condition as sent. Be especially sure to include details of any intermittent conditions--time after warmup, ways to induce intermittent, etc. You must ship the keyer postpaid and include \$2.50 return postage/handling in USA. (For other countries, add additional shipping charges as in ads or brochure.) If you do not enclose shipping charges, you will have to pay additional COD charges for return.

WARRANTY: Your keyer is warranted to the original purchaser to be free of defects in workmanship and materials for one full year. You must include purchase date (plus or minus one week) or other proof of original purchase and date, to qualify for free warranty work. THE WARRANTY IS VOID IF, IN OUR OPINION THE UNIT HAS BEEN MISUSED, ABUSED, MODIFIED IN ANY WAY OR TREATED IN ANY OTHER WAY CONTRARY TO THE INSTRUCTIONS OR WHICH MAY HAVE CONTRIBUTED TO A FAILURE.

If the unit is out of warranty, you must enclose a \$10 minimum service charge plus postage, as above, with the return. We can repair most problems for this minimum charge, but will inform you of any additional charges before completing the repairs.

The MK-1 is sold with a 15 day home trail. Your money will be refunded, less postage and insurance charges (\$2.50 in USA), if returned in "as new" or "as received" condition. The cost of repairing any damages, scratches, etc. caused by the user will be deducted from the refund. Any modifications void the return privilege. If you believe you have received a defective unit, and simply wish repair or replacement, we will extend the trial for another 15 days after we clear up any defects.

Less than 2% of our products are ever returned with defects. We're proud of this record, but are constantly trying to improve on it. But, if you have problems, we are here to help you.

#### 9. LATE NOTES

At this writing, 10 months into production, the MK-1 has proven to be not only inexpensive, but also quite reliable. We had some problems with a bad batch of .1uf capacitors in the monitor, and also with a bad batch of LED's. Other than these parts, which are no longer used, failures are usually confined to the IC's, which are easily replaced since they are socketed. Your unit is not only tested twice, but has been subject to a new burnin procedure which has been found to identify most of the marginal IC's before shipment. As a result, you have, we think, the most reliable keyer of its complexity ever made.

Several amateurs have added pushbuttons in parallel with the panel pushbuttons and mounted these outside the case in an external box. This will work, but bypass capacitors (.01 uf disc) should be used across the present buttons to keep RF out. Also, it is emphasized that this mod., or ANY MOD, voids the warranty, since mods. have been found to be a major source of failures. We can fix most problems for \$10 plus shipping (see above), so if you wish to modify, have fun! Just don't expect us to fix any failures for free! Also, we can't comment about any other mods, due to the large volume of mail that would result. So please do not bother to write asking about mods. We can supply no other information.

There is no easy way to use a straight key with the MK-1. Connecting a key across the MK-1 keyed output is perfectly safe, and will key the transmitter, but the MK-1 monitor will not go on.

We will probably offer a plug-in accessory to expand the MK-1 to a record 16 messages! This will sell for under \$50, and will work with ANY existing MK-1 ever made. (plugs into the memory IC socket). If you are interested, please drop a postcard immediately so we know if there is any demand for this option, and we'll mail details when available. Or check ads if available.

There has been only one failure of the MK-1 solid-state output transistors (ham tried to use it with an old 807 300 ma. cathode keyed rig.). So we're glad we didn't use a relay for keying, as the xistors are infinitely more reliable. However, we found that some Ten-Tec and the early models of the FT-301D cannot be keyed by the MK-1 directly. The solution is simple. Wire a 1.5 volt battery in series with the keyed output (observe polarity), and everything works fine. Current is drawn from the battery only when keying, and so even a tiny "C" battery should last for years. We understand Yaesu is aware of the problem, and is working on it.

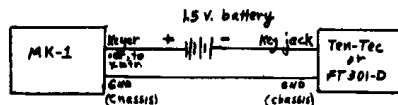

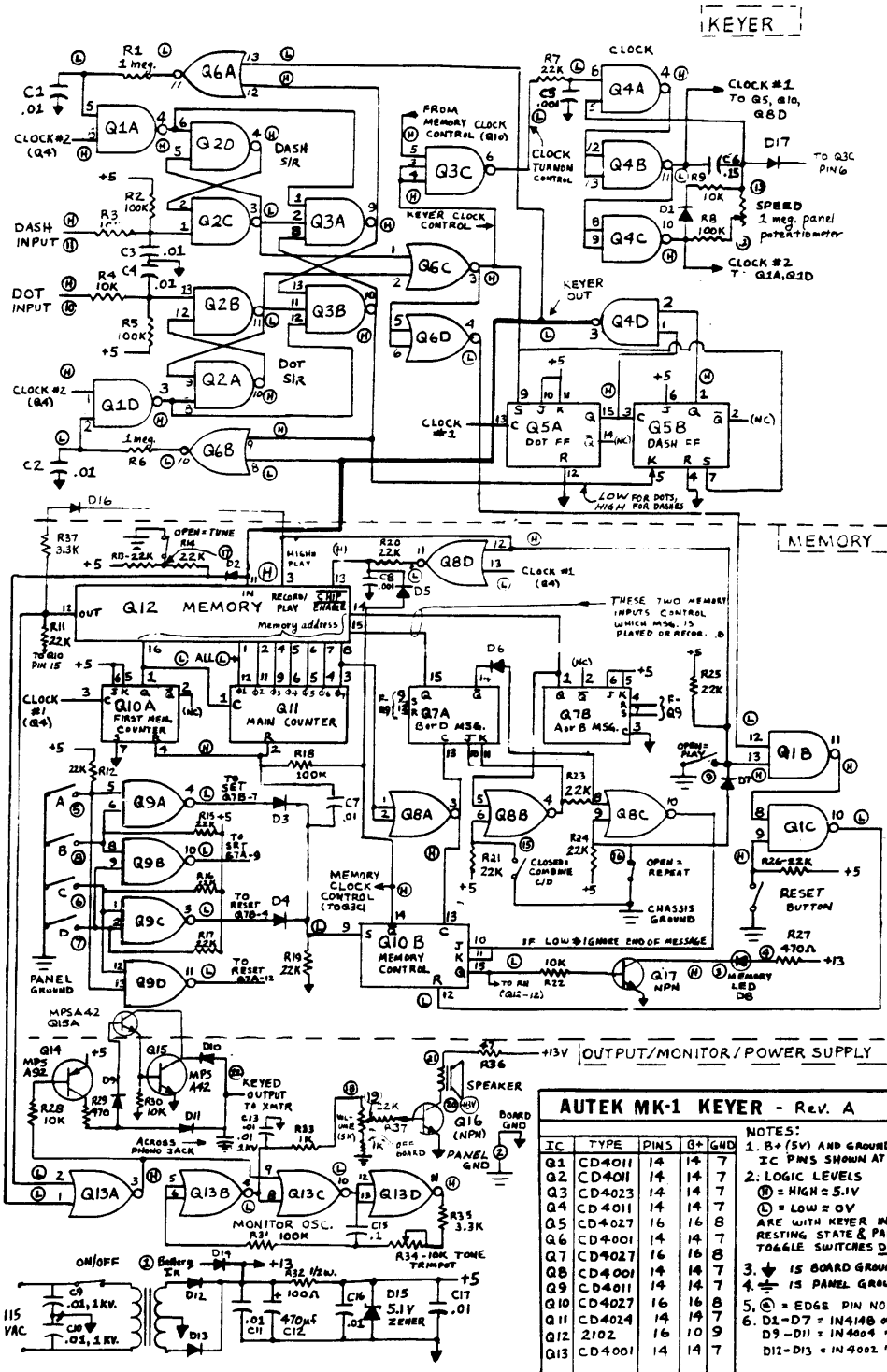

TURN TRIMPOT TO  
ADJUST TONE

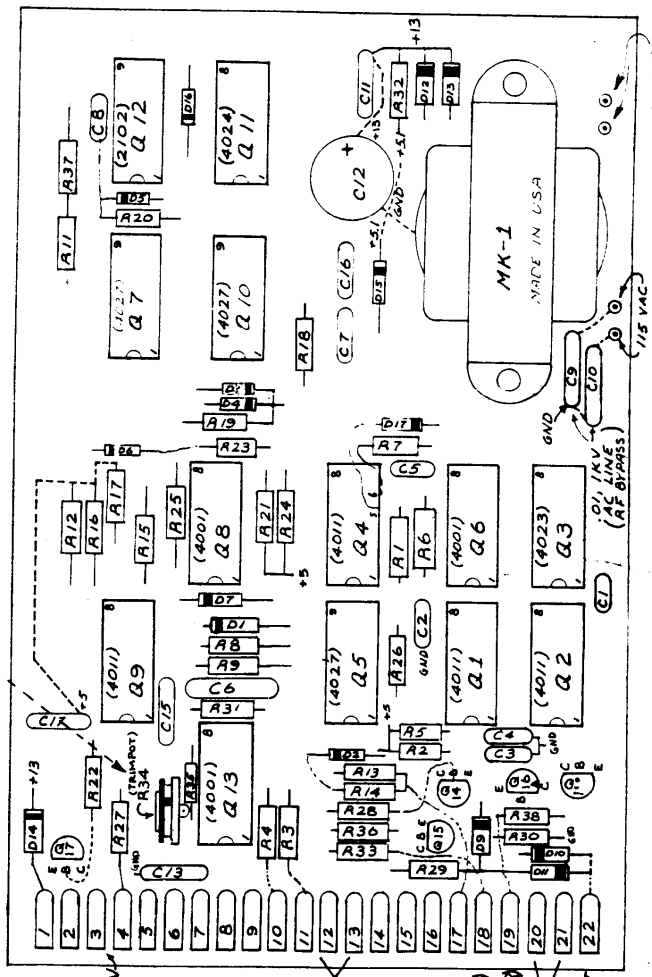

COMPONENT  
VALUES

R1	1M	Ω
R2	100K	
R3	10K	
R4	100K	
R5	100K	
R6	1M	
R7	22K	
R8	100K	
R9	10K	
R10	10K	
R11	22K	
R12	22K	
R13	22K	
R14	22K	
R15	22K	
R16	22K	
R17	22K	
R18	100K	
R19	22K	
R20	22K	
R21	22K	
R22	10K	
R23	22K	
R24	22K	
R25	22K	
R26	22K	
R27	470	
R28	10K	
R29	470	
R30	10K	
R31	100K	
R32	100	
R33	10K	
R34	10K	
R35	10K	
R36	47	Ω
R37	33K	
R38	22K	

10K 5% (IMPOT)

C1,2,3,4,7,11	.01
C5,8	.001
C9,10	.01
C6	.15
C15	.1

- 1 BATTERY IN
- 2 GROUND
- 3 TO LED-GND
- 4 TO LED+ RETURN
- 5 A
- 6 C
- 7 D
- 8 B
- 9 PLAY
- 10 DASH PADDLE
- 11 SPEED CONTROL
- 12 RESET BUTTON
- 13 COMBINE C/D
- 14 REPEAT
- 15 TUNE
- 16 VOLUME POT (END)
- 17 " (TAP, CENTER)
- 18 SPKR.
- 19 KEYED OUTPUT
- 20 (TO XMTR.)
- 21
- 22