

---

**TECHNICAL MANUAL**  
**OPERATION AND MAINTENANCE INSTRUCTIONS**

**OPERATIONAL LEVEL**

**RECEIVER, SINGLE,**  
**VLF - HF**  
**R-3050**

Cubic Communications, Incorporated  
P.O. Box 85587  
San Diego, California 92186-5587

Telephone: (619) 277-6780      Telex: 695435 Cubicom Ocen

Telefax: (619) 277-9353

---

---

TECHNICAL MANUAL

**OPERATION AND MAINTENANCE INSTRUCTIONS**

OPERATIONAL LEVEL

**RECEIVER, SINGLE,  
VLF - HF  
R-3050**

Cubic Communications, Incorporated

P.O. Box 85587

San Diego, California 92186-5587

Telephone: (619) 277-6780

Telex: 695435 Cubicom Ocen

Telefax: (619) 277-9353

---

**Issue 3.0**

**Change A**

**3 July 1991**

**26 September 1991**

CHANGE	DATE	TITLE OR BRIEF DESCRIPTION	ENTERED BY
A	26 SEP 1991	<p>Correct Block Diagram - Reference &amp; 2nd LO, and BFO</p> <p>Remove and replace the following pages:</p> <p>Title Page RECORD OF CHANGES (insert in front of page i) Page 4-3/4-4 Page FP-3/(FP-4 blank)</p>	Cubic

## FOREWORD

---

### SCOPE

This manual contains information for the installer and operator to obtain best performance from the R-3050 receiver. The information includes: an introduction to the equipment, specifications, installation, operation, operational maintenance (fault isolation, and module replacement procedures), theory of operation, and a replaceable parts list.

Component level maintenance is not included in this manual. Component level maintenance should be performed in the designated maintenance depot.

---

### WARNING

Do not apply power to the equipment until the installation procedures in Section 3 have been successfully completed.

---

### PROPRIETARY DATA

The information in this manual is the property of Cubic Communications Incorporated. Disclosure to a third party, either wholly or in part, without written consent from Cubic Communications Incorporated is prohibited.

---

### CORRECTION NOTICE

The information in this manual is believed correct at publication date. If a difference is noted between the information in this manual and the equipment, contact the factory for clarification. Current and future editions will be corrected as necessary.

---

### RIGHTS RESERVED

Cubic Communications Incorporated reserves the right to change the specifications, design, and fabrication methods of equipment at any time without notice.

---

## TABLE OF CONTENTS

Chapter	Page	Chapter	Page
FOREWORD.....	i	1-4 EQUIPMENT SUPPLIED AND REQUIRED.....	1-5
TABLE OF CONTENTS.....	ii	1-5 STORAGE DATA.....	1-5
LIST OF ILLUSTRATIONS.....	v	1-6 TOOLS AND TEST EQUIPMENT.....	1-5
LIST OF TABLES.....	v	1-7 SAFETY PRECAUTIONS.....	1-6
<b>1 GENERAL DESCRIPTION.....</b>	<b>1-1</b>	<b>2 PREPARATION FOR USE AND INSTALLATION</b>	
1-1 INTRODUCTION.....	1-1	<b>INSTRUCTIONS.....</b>	<b>2-1</b>
1-2 EQUIPMENT DESCRIPTION.....	1-1	2-1 INTRODUCTION.....	2-1
1-3 SPECIFICATIONS.....	1-1	2-2 UNPACKING AND INSPECTION.....	2-1
1-3.1 Electrical.....	1-1	2-3 INSTALLATION.....	2-1
1-3.1.1 Frequency.....	1-1	2-4 CONNECTIONS.....	2-2
1-3.1.2 Modes.....	1-1	2-4.1 Ground.....	2-2
1-3.1.3 RF Section.....	1-2	2-4.2 Frequency Standard.....	2-2
1-3.1.4 Preselection.....	1-2	2-4.3 1ST IF MON.....	2-2
1-3.1.5 IF Section.....	1-2	2-4.4 2ND IF and ISB MON.....	2-2
1-3.1.6 AGC.....	1-2	2-4.5 AUDIO and Analog Connector.....	2-2
1-3.1.7 Interference Immunity.....	1-2	2-4.6 Antenna(s).....	2-5
1-3.1.8 I/O Signals.....	1-3	2-4.7 Antenna Select Connector.....	2-5
1-3.1.9 Standard Connectors.....	1-3	2-4.8 Power.....	2-5
1-3.1.10 Power Requirements.....	1-3	2-4.9 IEEE-488 Bus Connector.....	2-5
1-3.2 Environmental.....	1-3	2-4.9.1 IEEE-488 Addressing and SRQ	
1-3.2.1 Temperature.....	1-3	Functions.....	2-5
1-3.2.2 Relative Humidity.....	1-3	2-4.10 Serial Bus Connector.....	2-7
1-3.2.3 Shock and Vibration.....	1-3	2-4.10.1 Serial Bus Addressing and	
1-3.2.4 Electromagnetic Emission.....	1-3	Configuration.....	2-7
1-3.3 Physical.....	1-4	<b>3 OPERATING INSTRUCTIONS.....</b>	<b>3-1</b>
1-3.3.1 Construction.....	1-4	<b>Section I. LOCAL CONTROL.....</b>	<b>3-1</b>
1-3.3.2 Maintainability.....	1-4	3-1 INTRODUCTION.....	3-1
1-3.3.3 Size.....	1-4	3-2 LOCAL OPERATION.....	3-1
1-3.3.4 Weight.....	1-4	3-2.1 Power On and Initial Set Up.....	3-1
1-3.3.5 Reliability.....	1-4	3-2.2 Initial Adjustments and	
1-3.4 Remote Control.....	1-4	Control Settings.....	3-1
1-3.4.1 Receiver Functions.....	1-4	3-2.3 Normal Operation.....	3-1
1-3.4.2 IEEE-488 Bus Functions.....	1-4	3-2.3.1 Setting or Changing Receiver	
1-3.4.3 Serial Bus Functions and		Functions.....	3-1
Description.....	1-4	3-2.3.1.1 Antenna.....	3-10
1-3.4.3.1 RS-232.....	1-5	3-2.3.1.2 Automatic Gain Control	
1-3.4.3.2 MIL-STD-188C.....	1-5	(AGC).....	3-10
1-3.4.3.3 MIL-STD-188-114 (Unbalanced).....	1-5	3-2.3.1.3 Bandwidth.....	3-10
1-3.4.3.4 RS-423.....	1-5		
1-3.4.3.5 MIL-STD-188-114 (Balanced).....	1-5		
1-3.4.3.6 RS-422.....	1-5		
1-3.4.3.7 RS-485.....	1-5		

## TABLE OF CONTENTS-Continued

Chapter	Page	Chapter	Page
3-2.3.1.4	Beat Frequency Oscillator (BFO).....3-11	3-4	REMOTE OPERATION USING IEEE-488 BUS.....3-25
3-2.3.1.5	Channel Data Recall.....3-11	3-4.1	IEEE-488 Bus Description.....3-25
3-2.3.1.6	Channel Data Storing.....3-11	3-4.2	IEEE-488 Bus Listen Data Sequence..3-26
3-2.3.1.7	Dwell Time Setting.....3-12	3-4.3	IEEE-488 Bus Talk Data Sequence....3-26
3-2.3.1.8	Frequency.....3-12	3-4.4	IEEE-488 Bus Serial Poll Status Byte.....3-26
3-2.3.1.9	IF Shift.....3-12	3-4.5	IEEE-488 Bus Talk Only Mode.....3-26
3-2.3.1.10	Manual Gain.....3-12	3-4.6	IEEE-488 Bus Listen Only Mode.....3-26
3-2.3.1.11	Meter Display.....3-13	<b>4</b>	<b>THEORY OF OPERATION.....4-1</b>
3-2.3.1.12	Mode.....3-13	4-1	INTRODUCTION.....4-1
3-2.3.1.13	Scan Starting & Stopping.3-13	4-2	SIGNAL PROCESSING.....4-1
3-2.3.1.14	Skipping Channels.....3-14	4-2.1	PRESELECTOR Module.....4-1
3-2.3.1.15	Skipping Frequencies.....3-15	4-2.2	1ST MIXER Module.....4-1
3-2.3.1.16	Special Functions.....3-15	4-2.3	2ND MIXER Module.....4-1
3-2.3.1.16.1	Software Ver. No....3-15	4-2.4	2ND IF Module.....4-1
3-2.3.1.16.2	Clr Sweep Skip Mem..3-15	4-2.5	DETECTOR Module.....4-1
3-2.3.1.16.3	Remote Control Bus Address.....3-15	4-2.5.1	FM Detector.....4-2
3-2.3.1.16.4	Serial Bus Baud Rate Selection....3-16	4-2.5.2	Envelope Detector.....4-2
3-2.3.1.16.5	Serial Bus Line Parameter Select..3-16	4-2.5.3	Product Detector.....4-2
3-2.3.1.16.6	Clear All Memory Channels.....3-16	4-2.6	ISB Module.....4-2
3-2.3.1.17	Step Increment Frequency Setting.....3-17	4-2.7	AUDIO Module.....4-2
3-2.3.1.18	Sweep Starting and Stopping.....3-17	4-2.8	Antenna Select Board.....4-2
3-2.3.1.19	Threshold Setting.....3-18	4-3	SYNTHESIZER.....4-3
<b>Section II. REMOTE CONTROL.....3-19</b>		4-3.1	OUTPUT LOOP Module.....4-3
3-3	REMOTE OPERATION USING SERIAL BUS.....3-19	4-3.2	STEP LOOP Module.....4-3
3-3.1	Serial Bus Description.....3-19	4-3.3	FINE LOOP Module.....4-3
3-3.2	Serial Bus Message Format.....3-19	4-3.4	REFERENCE & 2ND LO Module.....4-4
3-3.3	Serial Bus Message Types.....3-19	4-3.5	BFO Module.....4-4
3-3.3.1	Serial Bus Command Messages...3-19	4-4	CONTROL.....4-4
3-3.3.1.1	Serial Bus Radio Cmnd Msgs.3-19	4-4.1	CPU Module.....4-4
3-3.3.1.2	Serial Bus Interface Command Messages.....3-19	4-4.1.1	Data Flow.....4-5
3-3.3.2	Serial Bus Status Messages....3-19	4-4.1.2	Input/Output.....4-5
3-3.3.2.1	Serial Bus Radio Status Messages.....3-19	4-4.2	INTERFACE Module.....4-5
3-3.3.2.2	Serial Bus Interface Status Messages.....3-19	4-4.3	Display Board.....4-5
3-3.4	Serial Bus Message Protocol.....3-19	4-4.4	IEEE-488 Bus Interface Module.....4-5
3-3.4.1	Serial Bus Normal Mode.....3-19	4-4.5	IEEE-488 Bus Connector Board.....4-5
3-3.4.2	Serial Bus Acknowledge Mode...3-21	4-4.6	SERIAL Bus Interface Module.....4-5
3-3.4.3	Serial Bus Independent Mode...3-21	4-4.7	Serial Bus Connector Board.....4-6
3-3.5	Serial Bus Message Definition.....3-21	4-5	POWER DISTRIBUTION.....4-6
		4-5.1	POWER SUPPLY Module.....4-6
		4-5.2	AC Line Filter Board.....4-6

**TABLE OF CONTENTS-Continued**

Chapter	Page	Chapter	Page
<b>5 MAINTENANCE INSTRUCTIONS.....</b>	<b>5-1</b>	<b>6 PREPARATION FOR RESHIPMENT.....</b>	<b>6-1</b>
Section I. PREVENTIVE MAINTENANCE.....	5-1	6-1 INTRODUCTION.....	6-1
5-1 INTRODUCTION.....	5-1	6-2 DISASSEMBLY AND REMOVAL.....	6-1
5-2 CLEANING AND LUBRICATION.....	5-1	6-3 PACKAGING.....	6-1
5-3 INSPECTION.....	5-1	6-4 SHIPPING.....	6-1
5-3.1 External Inspection.....	5-1	<b>7 STORAGE.....</b>	<b>7-1</b>
5-3.2 Internal Inspection.....	5-1	7-1 INTRODUCTION.....	7-1
5-4 PERFORMANCE VERIFICATION.....	5-1	7-2 STORAGE ENVIRONMENT.....	7-1
5-4.1 Receiver Sensitivity.....	5-1	7-3 PRESERVATION.....	7-1
Section II. CORRECTIVE MAINTENANCE....	5-2	<b>8 REPLACEABLE PARTS.....</b>	<b>8-1</b>
5-5 TROUBLESHOOTING.....	5-2	8-1 INTRODUCTION.....	8-1
5-5.1 Fault Identification.....	5-2		
5-5.2 Initial Checks.....	5-2		
5-5.3 Fault LED Interpretation.....	5-2		
5-5.3.1 One Fault LED On.....	5-3		
5-5.3.2 Multiple Fault LEDs On.....	5-3		
5-5.3.3 No Fault LEDs On.....	5-3		
5-5.4 Signal Tracing.....	5-3		
5-6 MODULE REPLACEMENT.....	5-3		
5-6.1 Removal.....	5-3		
5-6.2 Replacement.....	5-3		
5-6.3 Reassembly.....	5-3		

## LIST OF ILLUSTRATIONS

Number		Page
1-1	R-3050 Front View.....	1-0
2-1	Rear Panel With Remote Control (Typical).....	2-3
2-2	Rear Panel With Dual Antenna Inputs (Typical).....	2-4
3-1	Keypad.....	3-3
3-2	Front Panel Display.....	3-5
3-3	Dwell Time Examples.....	3-13
3-4	Serial Bus Message Format.....	3-20
3-5	Serial Bus Character Format.....	3-20
3-6	IEEE-488 Bus Status Byte.....	3-32
FO-1	Outline and Mounting Drawing (Typical).....	FP-1
FO-2	Block Diagram (Typical).....	FP-3

## LIST OF TABLES

Number		Page
1-1	Serial Bus Characteristics.....	1-6
1-2	Items Furnished and Required.....	1-7
1-3	Recommended Tools and Test Equipment (Or Equivalent).....	1-7
2-1	Audio and Analog Connector Pin Descriptions.....	2-2
2-2	Antenna Select Connector Pin Descriptions.....	2-5
2-3	IEEE-488 Bus Remote Control Connector Pin Descriptions.....	2-6
2-4	RS-232 Bus Connector Pin Descriptions.....	2-7
2-5	RS-422 Bus Connector Pin Descriptions.....	2-7
3-1	Front Panel Controls.....	3-2
3-2	Keypad Functions.....	3-3
3-3	Display Functions.....	3-6
3-4	Recommended Preliminary Control Settings.....	3-9
3-5	Normal State Conditions.....	3-10
3-6	Special Functions.....	3-15
3-7	Serial Bus Interface Command Messages.....	3-21
3-8	Serial Bus Interface Status Messages.....	3-21
3-9	Serial Bus Radio Command/Status Messages.....	3-22
3-10	IEEE-488 Bus Management Signals.....	3-25
3-11	IEEE-488 Bus Handshake Lines.....	3-25
3-12	IEEE-488 Bus Listen Protocol.....	3-27
3-13	IEEE-488 Bus Capabilities.....	3-30
3-14	IEEE-488 Bus Controller Status Requests.....	3-31
5-1	Fault Isolation - One Fault LED.....	5-4
5-2	Fault Isolation - Multiple Fault LEDs.....	5-4
5-3	Fault Isolation - No Fault LEDs.....	5-4
5-4	Typical Rear Panel Monitor Signals.....	5-5
8-1	Replaceable Parts List.....	8-1

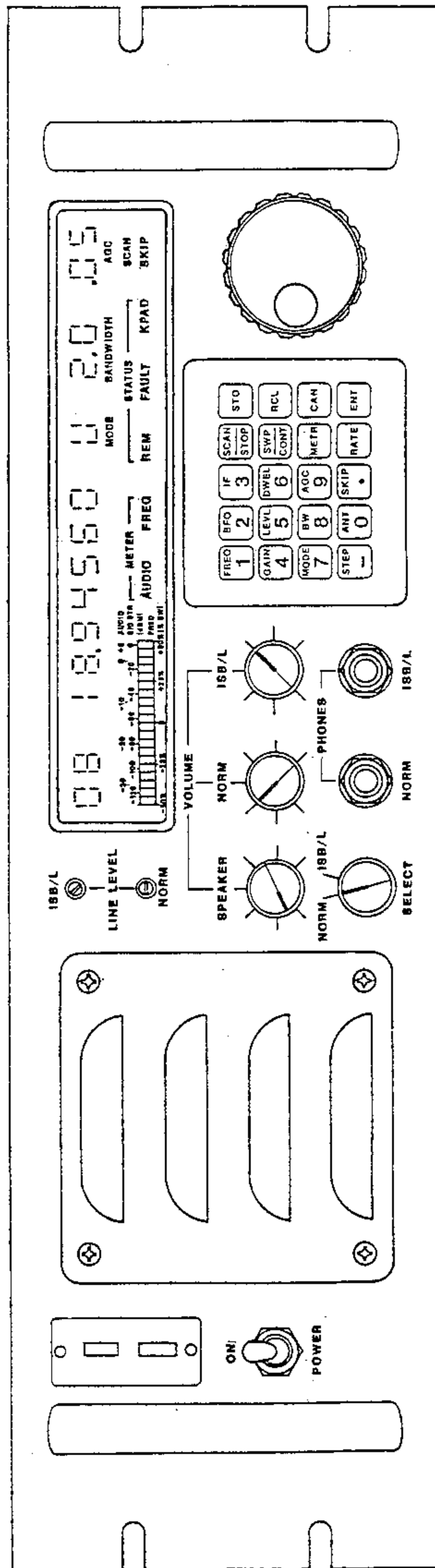

Figure 1-1. R-3050 Front View.

## CHAPTER 1

### GENERAL DESCRIPTION

**1-1 INTRODUCTION.** This chapter contains a description of the equipment, equipment supplied, equipment required but not supplied, storage data, recommended tools and test equipment, and safety precautions.

**1-2 EQUIPMENT DESCRIPTION.** The R-3050 (figure 1-1) is a high performance multi-mode receiver with a frequency range from 5 kHz to 30 MHz. The receiver can be operated locally (manually) or remotely. In remote control, the receiver is assigned a unique address and can be operated in groups of up to 14 receivers using an IEEE-488 remote control bus, or in groups of up to 30 receivers using a serial control bus.

Optional items include: type of remote control bus, bandpass filter bandwidths, antenna input select, and external reference frequency (1 or 10 MHz). The optional items are selected at the time of order of the receiver. Some options may be changed in the field. Contact the factory or procuring agency for details.

The unit contains individually shielded module assemblies. The modules are mounted in a 19 by 5 1/4 inch rack mount chassis, with control bus, audio, and AC power connectors on the rear panel.

The receiver may be operated locally by a 20 button keypad used to select frequency, mode, BFO offset, IF shift, manual gain, and other parameters. A manual adjustment knob also provides control of many of the above parameters. A front panel LED display provides frequency, mode, bandwidth, and AGC time constant as well as (when selected), BFO offset, IF shift, manual gain, threshold for squelch or scan stop, and other parameters. A light-bar meter indicates signal strength, audio signal level, or relative frequency of the input signal.

The receiver may be remotely controlled by an external computer using an optional remote control bus. Choice of tuned frequency, mode, BFO offset (when the CW mode is selected), AGC time constant, and other parameters are performed through the external computer. Consult the external computer's system operator manual for further information.

By proper selection of parameters, the receiver can detect and demodulate a wide variety of signals. These include: amplitude modulation (AM), on/off keyed (CW), upper sideband (USB), lower sideband (LSB), frequency modulation (FM), and independent sideband (ISB) (suppressed carrier and independent). Frequency shift keyed (FSK) signals can be demodulated as single sideband suppressed carrier signals or as true frequency modulated (FM) signals.

Detector outputs are available as audio signals on a 600 ohm balanced line. The levels are adjustable from the front panel. The FM detector output is also available as a DC coupled signal on a single ended line. An internal speaker, or headphones may be used. Headphone jacks are provided on the front panel. The audio signal level is controlled by front panel volume controls.

The first IF output (40.455 MHz) and second IF output (455 kHz) signals are available at rear panel connectors for display or analysis by other equipment. The normal 455 kHz output may be converted to another frequency if specially ordered.

### 1-3 SPECIFICATIONS.

#### 1-3.1 Electrical.

##### 1-3.1.1 Frequency.

Range: 5 kHz - 30 MHz (Tunes to 0 Hz, optimum above 50 kHz)

Resolution: 10 Hz steps

Accuracy: 1 part per million over temperature range, .01 parts per million per week aging

External Standard: Input/Output: 1 MHz or 10 MHz (option), 0 dBm

Synthesizer Lock Time 5 ms typical, 15 ms worst case

##### 1-3.1.2 Modes.

Selectable: LSB, USB, AM, CW, FM, ISB

Always Active: FM Video

## R-3050 TECHNICAL MANUAL

### 1-3.1.3 RF Section.

Input impedance: 50 ohms

Input VSWR: less than 3:1

Protection: Withstands application of RF power up to 100 Volts RMS from a 50 ohm source without damage.

Noise Figure: 13 dB maximum above 1600 kHz

Sensitivity for 10 dB SINAD (above 1600 kHz):

AM (6 kHz Bandwidth, 90% modulation) -107 dBm

CW (300 Hz Bandwidth) -126 dBm

ISB/SSB (2.7 kHz Bandwidth) -116 dBm

1-3.1.4 Preselection. RF input filter in eight bands covering 1.6-30 MHz in approximate one half octave bands. Band selection automatic and switched by PIN diodes. Filter shape factor approximately 8 to 1. Filters used below 1.6 MHz are relay switched for low signal distortion. Frequency bands are as follows:

Band	Frequencies (MHz)
1	0.000 to 0.4999
2	0.500 to 1.5999
3	1.600 to 2.2999
4	2.300 to 3.2999
5	3.300 to 4.7999
6	4.800 to 6.8999
7	6.900 to 9.8999
8	9.900 to 14.2999
9	14.300 to 20.4999
10	20.500 to 30.0000

### 1-3.1.5 IF Section.

IF Frequencies

First IF: 40.455 MHz, Second IF: 455 kHz

First IF Bandwidth: 10 or 20 kHz at -6 dB. (Option at time of order)

Second IF Bandwidths (Selectable). Up to six selections optionally available between .3 and 16 kHz at -6 dB. (Contact factory for details).

**NOTE:** LSB, USB, and ISB modes always select one fixed set of filter bandwidths which may be between 2 and 4 kHz depending on order requirements.

### 1-3.1.6 AGC. RF derived in selected bandwidth.

a. Fast attack, selectable decay, fast release

Attack Time: 15 ms maximum

Decay Time (Selectable):

Short: 50 ms nominal

Medium: 250 ms nominal

Long: 3 seconds nominal

Off: Remote or manual gain control only

b. Average type -- AM mode only using Envelope detector. Attack and release time constant 220 milliseconds nominal.

AGC Range: 120 dB minimum

AGC Threshold: 0.5 uV (-6 dB audio reference level at 50 uV)

AGC Disable: Automatic Gain Control or Manual Gain Reduction

Manual Gain Control: 0 to -127 dB gain reduction with AGC disabled

### 1-3.1.7 Interference Immunity.

IF Rejection: 100 dB typical

Image Rejection: 90 dB typical

Spurious Responses: -123 dBm equivalent or less for -50 dBm input signals

Generated Spurious: -123 dBm input equivalent or less, 2 to 30 MHz

Blocking: Attenuation of a wanted RF signal of -70 dBm and caused by an unmodulated unwanted signal of +10 dBm spaced 200 kHz away is less than 3 dB.

Inherent Oscillator Re-radiation: 1 uV, worst case from antenna connector into 50 ohms.

Intermodulation Distortion (typical): The 3rd order I.M. products resulting from two input signals at -20 dBm each less than -120 dBm.

1-3.1.8 I/O Signals.Outputs:

PHONES jack: NORM, ISB/L - mono, 33 ohms

1ST IF MON: 40.455 MHz with 1 MHz minimum bandwidth, 50 ohms at approx. 10 dB gain from input.

2ND IF MON: 455 kHz at selected bandwidth and nominal 0 dBm level. 0 ±3 dBm over AGC range

ISB MON: 455 kHz in ISB bandwidth (Lower sideband) -- above 455 kHz at IF. Level same as 2nd IF MON.

REF OUT: 0 dBm, 50 ohms, 1 or 10 MHz (option)

AUDIO connector:

Balanced Audio: (AM, SSB, CW) 0±3 dBm, (with AGC active). .5 V/kHz AC coupled (4 V p-p maximum) 600 ohms.

FM Video: (always present) 1 V per kHz (positive sense, DC coupled) 93 ohm single ended

Signal Strength: Analog voltages 0 to +5 V

ANTENNA SELECT: (not on all models) eight outputs on rear panel connector, +5 V or +12 V (option) to control external antenna relays or other equipment.

Inputs:

AC POWER: 40 Watts, 90 - 135 VAC or 180 - 260 VAC selectable on module, 47 - 420 Hz

Antenna(s): nominal 50 ohm input impedance

REF IN: 0 dBm, 50 ohms, 1 or 10 MHz (option)

AUDIO connector: Mute: (not on all models) ground potential to mute, pulled high internally when open

1-3.1.9 Standard Connectors. (options available)

ANTENNA: N Female, 0-30 MHz

1ST IF MON: BNC Female, 40.455 MHz

2ND IF MON: BNC Female, 455 kHz

ISB MON: BNC Female, 455 kHz

REF IN: BNC Female, 1 or 10 MHz (option)

REF OUT: BNC Female, 1 or 10 MHz (option)

IEEE-488 BUS: (24 cont.) Amphenol Blue Ribbon IEEE-488 stacking connector or;

SERIAL BUS: As required per order

AUDIO: (19 contacts) MS3112E14-19S mates with MS3116E-14-19P, MS3116F-14-19P, or MS3116J-14-19P.

AC POWER: (3 contacts) IEC or CEE Standard AC connector

ANTENNA SELECT: MS3112E-12-10S mates with MS3116F-12-10P (10 contacts)

1-3.1.10 Power Requirements. 90 to 135 VAC or 180 to 260 VAC (selectable), 47 to 420 Hz, 40 watts maximum

1-3.2 Environmental.

1-3.2.1 Temperature. -20°C to +60°C Operating, -40°C to +70°C Storage. Tested to MIL-STD-810D, Method 501.2, Table 501.2-111 and MIL-STD-810D, Method 501.2, Table 2.2-1.

1-3.2.2 Relative Humidity. Humidity test per MIL-STD-810D, Method 507.2, Procedure I, Temperature 50°C, Figure 507.2-1, 5 total cycles.

1-3.2.3 Shock and Vibration. Shock per MIL-STD-810D, Method 516.3 Fig. 516.3-4 20g 11 ms sawtooth, 30g 11 ms in one axis. High impact shock per MIL-S-910C. Vibration per MIL-STD-810d, Method 514.3, Figure 514.3-36  $W_0 = .003g^2/Hz$  (Random)

1-3.2.4 Electromagnetic Emission. In conformance with the applicable provisions of MIL-STD-461B, class A1a as applicable to Navy and Air Force procurements. Filtering in conformance with MIL-STD-461B, section 4.2.1.

Requirements per MIL-STD-461B as follows:

CE01	Conducted Emissions, Power and Interconnecting Leads, Low Frequency (up to 15 kHz)
CE03	Conducted Emissions, Power and Interconnecting Leads, 0.015 - 50 MHz
CE07	Conducted Emissions, Pwr Leads, Spikes, Time Domain
CS01	Conducted Suscept., Pwr Leads 30 Hz - 50 kHz
CS02	Conducted Suscept., Pwr Leads 0.05 - 400 MHz
CS06	Conducted Susceptibility, Spikes, Power Leads
RE01	Radiated Emissions, Mag. Field, 0.03 - 50 kHz
RE02	Radiated Emiss., Elect. Field, 14 kHz - 10 GHz
RS01	Radiated Suscept., Mag. Field, 0.03 - 50 kHz
RS02	Radiated Suscept., Mag. Induction Field, Spikes and Power Frequencies
RS03	Radiated Suscept. Elec. Field, 14 kHz - 40 GHz

1-3.3 Physical.

1-3.3.1 Construction. All chassis and module assemblies use chem-film treated aluminum alloy and stainless steel hardware in accordance with the provisions of sections 3.4.9.13 and 3.4.11.2 (j) of MIL-E-16400. No steel or other materials subject to destructive corrosion are used.

The front panel is painted with semi-gloss light gray enamel in accordance with the requirements of MIL-E-15090, Class 2, Type II or Type III, color number 26307 of FED-STD-595, with black legends and handles. Finish of all painted surfaces is in accordance with the provisions of section 3.4.11.3 of MIL-E-16400.

1-3.3.2 Maintainability. Access to replaceable module assemblies is by means of 1/4 turn captive fasteners. Modules are secured with 1/4 turn captive fasteners. Correct module position in assembly indicated by a diagonal stripe on the module top surfaces.

1-3.3.3 Size. Modules for one complete receiver are packaged in one standard 5.25" X 19" rack panel and chassis with provisions for mounting slides. Slides are furnished if specified on the purchase order.

Depth, including protective handles, is approximately 17.5" behind the front panel. Connectors on the rear panel are inside the handle dimensions and are protected by the handles and chassis from contact with any flat surface large enough to contact both handles simultaneously at any angle of contact.

1-3.3.4 Weight. Approximately 35 pounds.

1-3.3.5 Reliability. The calculated Mean Time Between Failures is approximately 5000 hours per receiver unit when calculated using the methods and failure rates of MIL-HDBK-217D with failure rates of unrated components calculated using the methods of MIL-HDBK-217D.

1-3.4 Remote Control. (Not on all models). IEEE-488 or Serial Bus (one only).

1-3.4.1 Receiver Functions. (Either IEEE-488 or Serial Bus.)

- a. Selected Frequency (10 Hz increments)
- b. Modes: LSB, USB, ISB, AM, CW, or FM
- c. IF Bandwidth (1 of 6 from .3 to 16 kHz)

- d. BFO Frequency ( $\pm 9.99$  kHz shift in 10 Hz steps)
- e. IF Shift ( $\pm 9.99$  kHz shift in 10 Hz steps)
- f. Automatic or Remote Gain Control
- g. AGC Hold Time (0, 50, 250, or 3000 msec)  
Note: AM selects 50 msec AGC
- h. IF Gain (0 to -127 dB reduction in 1 dB steps with AGC disabled)
- i. Start and Stop of Sweep and Scan Functions

1-3.4.2 IEEE-488 Bus Functions. When the optional IEEE-488 module and CPU software is installed, the receiver implements the following IEEE-488 bus functions:

Code	Description/Comments
SH1	Source Handshake Standard
AH1	Acceptor Handshake Standard
T5	Talker No Extended Capability
L3	Listener No Extended Capability
SR1	Service Request rear panel switchable SRQ enable
RL1	Remote, Local REM and GTO, no LLO
DC1	Device Clear Standard
DT1	Device Trigger Standard with GET command

Interface: Driver and receiver circuits are Bus compatible. Receivers contain Bus terminating resistors and have 500 mV hysteresis. Drivers are three-state devices, capable of driving up to 15 other Bus compatible devices. Power up/down protection is included to prevent transmitting invalid data to the Bus.

Format: Sixteen lines, eight data and eight for control status message. Data transfer is byte serial using a three-wire handshake per IEEE-488 Standard.

Transfer Rates: Data transfer rates is typically 11K bytes/sec when talking and 5K bytes/sec when listening.

1-3.4.3 Serial Bus Functions and Description. The serial bus interface module is capable of communicating in all normal serial asynchronous modes. A specific serial bus connector plate and adapter board is required for each type of bus. At the time of publication, the following buses are available. Contact the factory for additional information.

- RS-232C, single drop
- RS-422A or RS-449, multiple drop

With the serial bus interface module and appropriate bus connector board installed, the receiver may be controlled in all normal functions.

Depending on the type of connector board installed in the receivers, a number of different serial data buses may be accommodated. These may include the EIA RS-232, EIA RS-422, EIA RS-423, EIA RS-485, or MIL-STD-188 as required by the application. These specifications do not actually call out a bus structure but only a method of signaling on a set of wires. Unlike the IEEE-488 standard, all messages must be defined for the unit being controlled and do not follow any bus protocol except for that defined by the equipment.

Bus characteristics are listed in table 1-1.

1-3.4.3.1 RS-232. The RS-232 bus is an unbalanced bus capable of signaling over short distances and with limited data rates. This bus is ordinarily used over distances of up to 50 feet with a single controller and single controlled device. This bus uses two single wires (one for each direction of transmission) and ground and is generally found to be disturbed by noise or other common mode signals over distances greater than a few meters.

1-3.4.3.2 MIL-STD-188C. The MIL-STD-188C bus is similar to the RS-232 bus except for a more limited voltage swing (+ and - 5 to 7 volts instead of + and - 5 to 15 volts) and for the fact that the mark and space conditions are defined opposite to the RS-232 standard. The same limitations on the use of the RS-232 apply to the MIL-STD-188C bus.

1-3.4.3.3 MIL-STD-188-114 (Unbalanced). This bus is similar to the other unbalanced buses discussed above except that the standard requires a differential bus receiver to sense signal against the ground lead and hence allows for transmission over distances of up to 4000 feet (with a baud rate less than 1000). Transmission at rates up to 100 K Baud are recognized with cable lengths no longer than 40 feet. As with the other unbalanced buses, the signal path consists of a single wire for each direction of transmission plus a common signal ground wire. The output signal swings are limited to + and - 4 to 6 volts around signal ground. This standard allows for up to 10 receivers with a single driver.

1-3.4.3.4 RS-423. This bus is similar to the MIL-STD-188-144 (Unbalanced) bus except that controlled linear wave shaping allows signaling at rates of up to 9000 baud for 4000 feet of cable. Waveshaping with RC time constants limits the baud rate to 3000 for 4000 feet of cable and the maximum baud rate is limited under any condition to 100 K baud. As with all unbalanced buses,

common mode noise can be a serious problem with long cable runs in the presence of other electrical noise sources and usually provides a baud rate and cable length limit much less than that listed above. This standard allows for up to 10 receivers with a single driver.

1-3.4.3.5 MIL-STD-188-114 (Balanced). This is a balanced bus with signaling being performed by the differential voltage between two wires and works well in the presence of relatively large common mode voltages. A separate pair of wires is used for each direction of data transmission for this and for the other balanced buses. Signaling is allowed at rates of up to 100 K baud with cable length of 4000 feet and with rates of up to 10 M baud with cable length of 40 feet. Exceptional rejection of common mode noise results from this bus configuration. This standard allows for up to 10 receivers with a single driver.

1-3.4.3.6 RS-422. This is a balanced bus similar to the MIL-STD-188-114 (Balanced) bus discussed above. This standard uses up to 10 receivers with a single driver. Some systems may have a larger number of bus receivers.

1-3.4.3.7 RS-485. The RS-485 bus is the only bus defined that allows for multiple bus transmitters or drivers. The standard allows for up to 32 drivers and 32 receivers on the bus. The bus receivers are high impedance under all conditions (including power off) while the bus transmitters are high impedance until commanded to transmit. This bus is similar to the RS-422 and MIL-STD-188-114 (Balanced) bus and shares similar characteristics. This bus uses a single pair of wires.

**1-4 EQUIPMENT SUPPLIED AND REQUIRED.** Table 1-2 lists the items furnished, items required but not supplied, and optional items.

**1-5 STORAGE DATA.** There are no special storage requirements for the R-3050. The equipment should be stored indoors in the original shipping container if available.

**1-6 TOOLS AND TEST EQUIPMENT.** Table 1-3 lists recommended tools and test equipment for operational level maintenance. There are no special tools or test equipment required.

Table 1-1. Serial Bus Characteristics.

SPECIFICATION	EIA RS-232	EIA RS-422	EIA RS-423	EIA RS-485	MIL-STD-188-114 SEC. 5.1	MIL-STD-188-114 SEC. 5.2	MIL-STD-188C SEC. 7.2
<b>GENERAL:</b>							
MODE	UNBALANCED	BALANCED	UNBALANCED	BALANCED	BALANCED	UNBALANCED	UNBALANCED
DRIVERS	1	1	1	32	1	1	1
RECEIVERS	1	10	10	32	10	10	1
MAX LENGTH	NO SPEC	4000 FT	4000 FT	4000 FT	4000 FT	4000 FT	NO SPEC
@ BD RATE	NO SPEC	100 K	3 K	100 K	100 K	1 K	NO SPEC
MAX BD RATE	20 K	10 M	100 K	10 M	10 M	100 K	NO SPEC
@ LENGTH	NO SPEC	40 FT	100 FT	40 FT	40 FT	40 FT	NO SPEC
MARK	NEG	NEG	NEG	NEG	NEG	NEG	POS
<b>DRIVER CHARACTERISTICS:</b>							
MIN OUT	+5 V	+2 V	+3.6 V	+1.5 V	+2 V	+4 V	+5 V
MAX OUT	+15 V	+6 V	+6 V		+6 V	+6 V	+7 V
LOAD RESIST. (ohms)	3-7 K	100 MIN	450 MIN	60 MIN	90 MIN	400 MIN	NO SPEC
OFF RESIST. (ohms)	300	60 K	60 K	120 K	60 K	60 K	NO SPEC
<b>RECEIVER CHARACTERISTICS:</b>							
RESIST. ohms	3-7 K	4 K MIN	4 K MIN	12 K MIN	4 K MIN	4 K MIN	6 K MIN
SENS.	+3.0 V	+0.2 V	+0.2 V	+0.2 V	+0.2 V	+3.0 V	+0.6 V
COM MODE	N/A	+7.0 V	N/A	+12/-7 V	+7.0 V	N/A	N/A

**1-7 SAFETY PRECAUTIONS.** Safety precautions are presented in this manual preceded by the word **WARNING** or **CAUTION** just prior to the point where the hazard is likely to be encountered. Warnings and cautions are defined as follows:

**WARNING**

Refers to a procedure or practice that, if not correctly followed, could result in injury, death, or long term health hazard.

**CAUTION**

Refers to a procedure or practice that, if not correctly followed, could result in equipment damage or destruction.

**Table 1-2. Items Furnished and Required.**

Part No.	Nomenclature	Furn./Reqd.
2541-1000-( )	Receiver, VLF-HF, R-3050	Furnished
-	AC power cord	Furnished
-	Bus Controller and attaching cables	Optl. Not supplied
-	External Reference Frequency	Optl. Not supplied
-	Antenna(s) and attaching RF cables	Reqd. Not supplied
-	External antenna switch (some models)	Optl. Not supplied
-	AC power source	Reqd. Not supplied

**Table 1-3. Recommended Tools and Test Equipment (Or Equivalent).**

Part No.	Nomenclature	Manufacturer
-	No. 2 Phillips screwdriver, 6 in.	Standard Issue
-	Small plastic or wood pry-bar	Locally procured
HP8656B	RF signal generator	Hewlett Packard
465B	Oscilloscope	Tektronix
8050A	Digital multimeter	Fluke
HP5381A	Frequency counter	Hewlett Packard
HP8568	Spectrum analyzer <sup>1</sup>	Hewlett Packard
<sup>1</sup> Optional		

**(This Page Intentionally Left Blank)**

## CHAPTER 2

### PREPARATION FOR USE AND INSTALLATION INSTRUCTIONS

**2-1 INTRODUCTION.** This chapter contains unpacking, inspection, installation, connections, and initial alignment procedures.

**2-2 UNPACKING AND INSPECTION.** To unpack and inspect the receiver for damage, perform the following procedures:

1. Inspect the shipping carton for damage before unpacking the receiver.

#### NOTE

If the carton is damaged, open the carton in the presence of a shipping carrier agent if possible. If damage is found after the receiver is unpacked, retain the carton and packing materials for inspection.

2. Open the carton and remove the foam packing material on top of the receiver.
3. Lift the receiver from the carton.

#### NOTE

The carton should be saved for possible reshipment.

4. Inspect the receiver for external damage including dents and scratches.
5. If external damage is found, remove the top and bottom covers of the receiver using a no. 2 Phillips screwdriver. Push down, and turn all captive fasteners on the covers 1/4 turn counter-clockwise. Inspect for internal damage such as loose or damaged modules.

#### CAUTION

Do not attempt to operate the receiver if internal damage is found.

**2-3 INSTALLATION.** The receiver is designed for rack slide mounting in a relatively dust free environment with an ambient temperature range between -20 and +60°C).

Before installing the equipment, remove the top cover to check/set the correct input voltage as follows:

#### **WARNING**

When the top cover is removed, high voltage may be present at the rear panel AC power connector, the AC Line Filter board, and the front panel POWER switch connections. Use caution when working in these areas.

#### CAUTION

Do not support the weight of the unit by the front panel alone. The chassis may bend or warp. Use chassis slides or a suitable support shelf.

1. Using a no. 2 Phillips screwdriver, push down, and turn all captive fasteners on the top cover 1/4 turn counter-clockwise.
2. Remove the top cover.

#### CAUTION

Ensure the switch on the POWER SUPPLY module is set to the corresponding input voltage position or the equipment may be damaged when power is applied.

3. Locate the POWER SUPPLY module in the rear of the chassis, and ensure the rotary switch on top of the module is set to the corresponding input voltage position.
4. Replace top cover, and lock captive fasteners by pushing down, and turning all captive fasteners 1/4 turn clockwise.

#### CAUTION

Ensure slide mounting screws are of the proper length. If screws are too long internal equipment may be damaged.

**NOTE**

See figure FO-1 for clearance requirements and mounting details.

5. Securely mount the outer section of the slides to the rack cabinet being sure to select the correct mounting holes.
6. Attach indicated right and left slide rails to each side of unit.
7. Before tightening the mounting screws, slide the chassis assembly into the rack mounted portion of the slides and adjust the hardware position as required for a smooth sliding fit.
8. Remove unit from rack and securely tighten all hardware.

**2-4 CONNECTIONS.** The following paragraphs describe the rear panel connections to the unit. (See figure 2-1 or 2-2.)

**2-4.1 Ground.** Optionally connect a ground wire to the GND stud. This connection is only required to reduce ground loop interference if present.

**2-4.2 Frequency Standard.** The unit may use either its internal frequency standard or an external frequency standard. The internal frequency standard provides an overall frequency accuracy of approximately 1 part per million (30 Hz at the highest frequency).

With the rear panel reference select switch set to the INT REF position, the rear panel REF OUT connector provides an output from the internal standard. Output frequency is 1 MHz (optionally 10 MHz) and is approximately a sine wave at 0 dBm into a 50 ohm load.

With the rear panel reference switch set to the EXT REF position, the rear panel REF IN connector will accept an input from an external frequency standard. The unit requires a sine or square wave at the reference frequency with a level of 0 dBm. Input impedance is approximately 1 K ohms. With the rear panel reference select switch set to the EXT REF position, the rear panel REF OUT connector provides an output from the external standard.

Set the selector switch to the desired position. If required, connect coaxial cables from the frequency standard connectors to a frequency measuring device, another receiver, or an external frequency standard.

**2-4.3 1ST IF MON.** The wideband 1ST IF MON(itor) output signal is centered at 40.455 MHz with a bandwidth of approximately 1 MHz. The signal level is approximately 10 dB greater than the signal level at the antenna input. This output may be used for wideband reception modes or connected to a spectrum analyzer.

**2-4.4 2ND IF and ISB MON.** The narrow-band 2ND IF MON(itor) signal is available for monitoring. The bandwidth is determined by the selected IF filter. The signal level is established by the AGC circuits at approximately -3 to +3 dBm into a 50 ohm load over an input signal level range of -110 dBm (1 microvolt) to -10 dBm. A similar signal is available on the ISB MON connector with the bandwidth set by the filter in the ISB module.

**2-4.5 AUDIO and Analog Connector.** The audio and analog connector is a military standard type with solder type female contacts on the receiver. The cable end has pin type contacts. The chassis mounted connector is type MS3112E14-19S. The mating cable connector may be type MS3116F14-19P or MS3116J14-19P or other equivalent types. The signals on this connector are listed in table 2-1.

**Table 2-1. Audio and Analog Connector Pin Descriptions.**

PIN	SIGNAL	REMARKS
A	GND	Chassis ground
E	MUTE	Ground to mute
F	SPKR RTN	Speaker audio return <sup>1</sup>
G	FM VID RTN	FM video return (73 ohms)
H	FM VID	FM video (73 ohms)
J	SPKR OUT	Speaker audio <sup>1</sup>
K	AUD DATA	Audio data
L	AUD COM	Audio common
M	DET AUD	Detector audio (600 ohms) <sup>1</sup>
N	DET AUD RTN	Detector audio return (600 ohms) <sup>1</sup>
P	ISB AUD	ISB audio (600 ohms)
R	ISB AUD RTN	ISB audio return (600 ohms)
S	DET SIG STR ANA	Detector signal strength analog
T	DET SIG STR RTN	Detector signal analog return
U	ISB SIG STR ANA	ISB signal strength analog
V	ISB SIG STR RTN	ISB signal strength analog return

<sup>1</sup>Also wired in parallel with terminal strip connections on rear panel (some models).



REMOTE

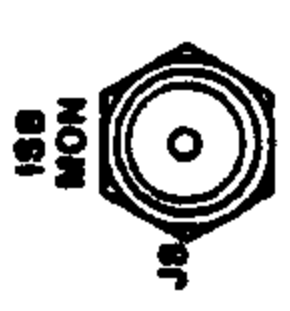
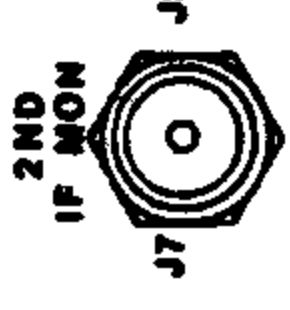
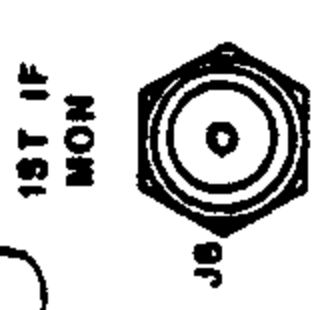
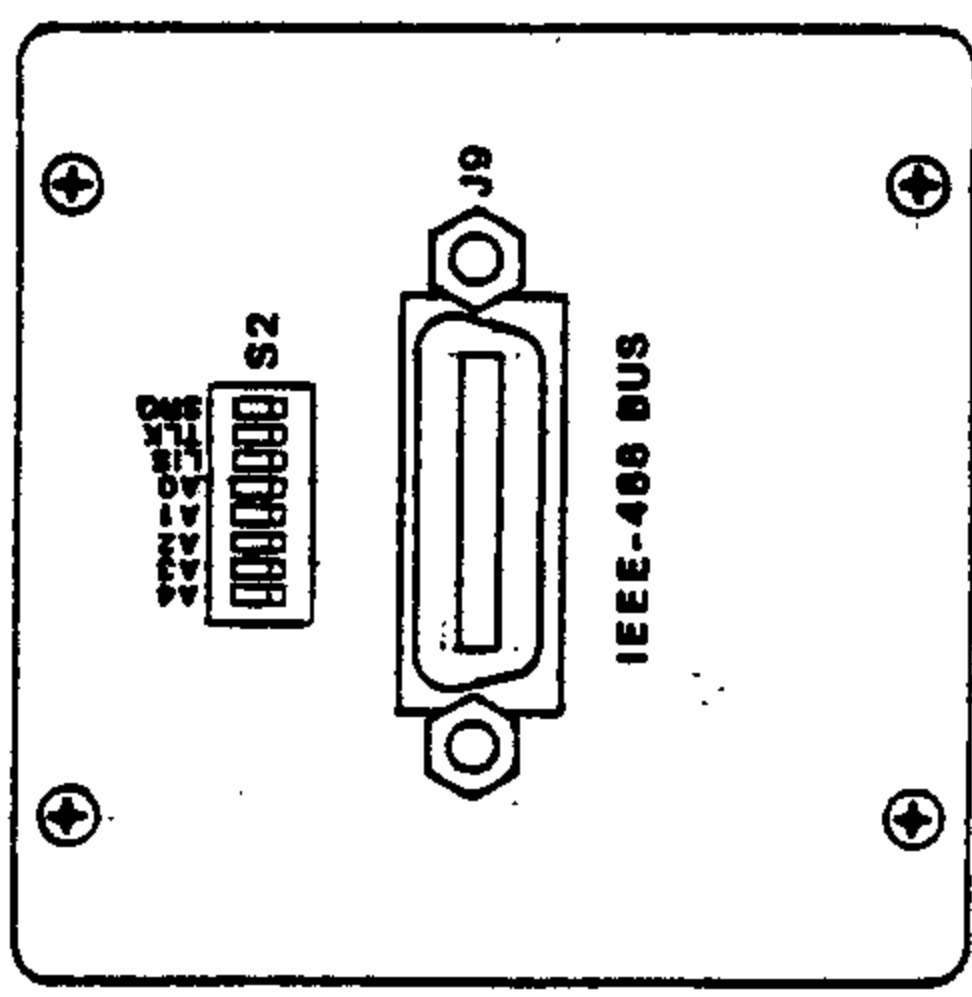
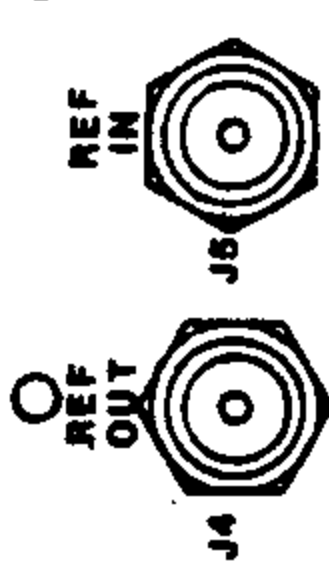
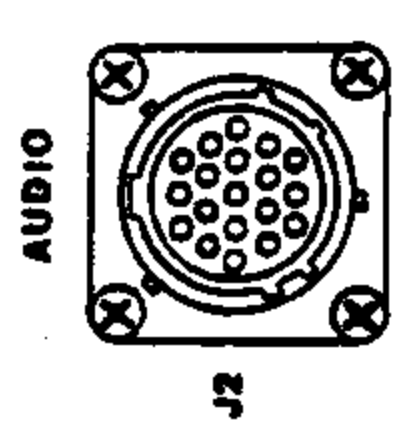
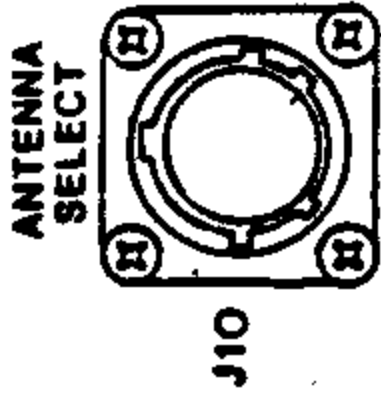
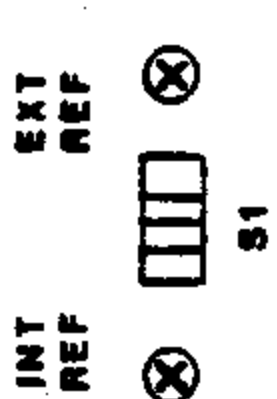
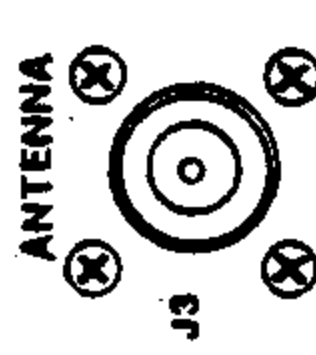

AC POWER

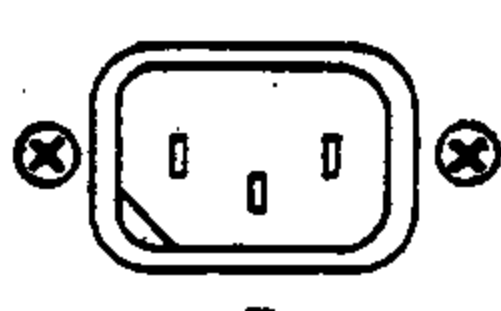

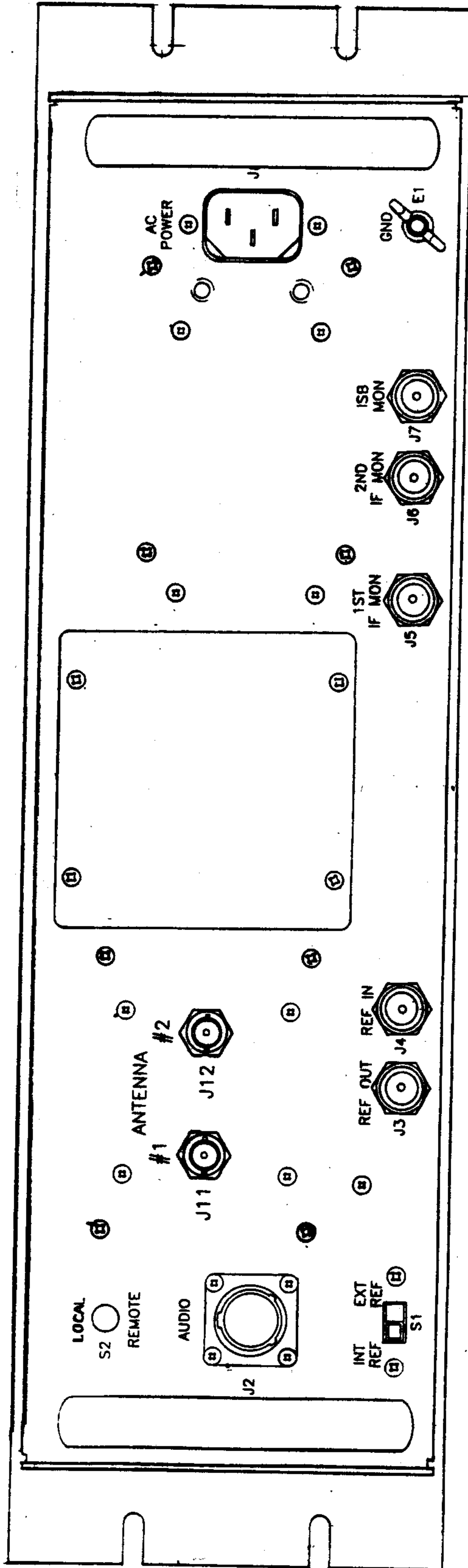

Figure 2-2. Rear Panel With Dual Antenna Inputs (Typical).

### 2-4.6 Antenna(s).

#### NOTE

Some models have two keypad selectable antenna connectors.

Connect the antenna to the antenna connector(s) on the rear panel. The impedance presented to the antenna is approximately 50 ohms with a VSWR less than 3 to 1 at the receiver tuned frequency and in the preselector frequency band corresponding to the receiver frequency.

**2-4.7 Antenna Select Connector.** The antenna select connector (not on all models) is located on the rear panel and is used to control external antenna relays or other equipment. This connector is a military standard type with solder type female contacts on the receiver. The cable end has pin type contacts. The chassis mounted connector is type MS3112E-12-10S. The mating cable connector may be type MS3116F-12-10P or equivalent. The signal voltage may optionally be +5 or +12 V. The signals are listed in table 2-2.

**Table 2-2. Antenna Select Connector Pin Descriptions.**

PIN	SIGNAL	REMARKS
A	GND	GROUND
B	COM	RELAY COMMON
C	ANT1	ANTENNA SELECT 1
D	ANT2	ANTENNA SELECT 2
E	ANT3	ANTENNA SELECT 3
F	ANT4	ANTENNA SELECT 4
G	ANT5	ANTENNA SELECT 5
J	ANT7	ANTENNA SELECT 7
K	ANT8	ANTENNA SELECT 8

**2-4.8 Power.** The unit is powered from either 90 to 135 VAC or 180 to 260 VAC, 47 to 420 Hz. The AC power connector is an international standard type with a separate chassis ground pin. A cord mounted socket is used to make contact with this connector. A cable retaining plate is used to prevent the AC cord from being accidentally removed from the unit when removing the unit from its mounting position.

A mating cord set is provided with a U.S.A. standard 3 pin plug for 115 VAC service. If a different plug is required, either cut off the U.S.A. standard plug and

replace it with the desired plug or replace the cord set. The U.S.A. standard cord uses the black wire for the AC line hot side, the white wire for the AC line neutral, and the green wire for ground. Only the green wire is connected to the chassis. International color code for these functions is a light blue wire for the AC line live side, a brown wire for the AC line neutral, and a green wire with a yellow tracer for the chassis ground. Either type of color code may be found in the power cable.

**2-4.9 IEEE-488 Bus Connector.** If the unit is configured for remote control using a IEEE-488 bus, connection of the unit to the bus is made with a standard IEEE-488 24-pin Blue Ribbon type connector. A commercially manufactured cable should be used. Make sure both the cable and connectors are completely shielded. The receiver bus connector is on the rear panel connector plate. Pin descriptions are listed in table 2-3.

Cable requirements for the IEEE-488 bus are determined by the actual system design. Refer to the hardware installation instructions provided with the Bus Controller. The bus cables may be configured in either a star or daisy-chain. Any combination of the two configurations may be used provided the total cable length does not exceed 20 meters (65.5 feet) or 2 meters (6.5 feet) for each bus device connected, whichever is less. The IEEE-488 bus connector on the rear panel is the type specified in the IEEE-488-1972 standard and uses metric studs. Make sure the locking devices are engaged on all connectors in the system.

**2-4.9.1 IEEE-488 Addressing and SRO Functions.** The receiver's bus address is selectable from 0 through 30 at the rear panel address switches using 5 of the 8 switches. The other 3 switches are used to enable the Talker Only, Listener Only, and SRQ functions. In normal operation, the talker only (T) and listener only (L) functions are not enabled. The receiver functions both as a talker and listener. The SRQ Enable function may be used by the system controller software if desired.

Each receiver must be configured to a unique bus address. This is done by setting the DIP switch on the rear panel to the desired address between 0 and 30. The DIP switch has eight small switches that can be in either the up (on) position or the down (off) position. The address is set into the five left most switches in a binary code with switch number A4 as the most significant bit and switch number A0 as the least significant bit. Refer to the NOTE in table 2-3 and set the address switches as required.

**Table 2-3. IEEE-488 Bus Remote Control Connector Pin Descriptions.**

PIN	FUNCTION	REMARKS
1	D1	Data Bit 1
2	D2	Data Bit 2
3	D3	Data Bit 3
4	D4	Data Bit 4
5	EOI	End Or Identify (Bus management)
6	DAV	Data Valid (Handshake)
7	NRFD	Not Ready For Data (Handshake)
8	NDAC	Not Data Accepted (Handshake)
9	IFC	Interface Clear (Bus management)
10	SRQ	Service Request (Bus management)
11	ATN	Attention (Bus management)
12	SHIELD	-
13	D5	Data Bit 5
14	D6	Data Bit 6
15	D7	Data Bit 7
16	D8	Data Bit 8
17	REN	Remote Enable (Bus management)
18	GND 6	Twisted with pin 6
19	GND 7	Twisted with pin 7
20	GND 8	Twisted with pin 8
21	GND 9	Twisted with pin 9
22	GND 10	Twisted with pin 10
23	GND 11	Twisted with pin 11
24	LOGIC GND	Signal common

NOTE: Set the DIP switch on the rear panel for each receiver as follows: (0 = switch down, 1 = switch up). For normal operation, set the TLK and LIS switches down and the SRQ switch up. This turns off the talker only and listen only modes and enables the service request mode. If the switches are changed while power is applied, turn the POWER switch momentarily off and then on for the unit to recognize the new address. When choosing addresses, be sure that the number selected is not in use by any other device on the bus.

**ADDRESS SWITCHES (A4 - A0):**

BUS CODE	BUS CODE	BUS CODE	BUS CODE
<u>ADR 43210</u>	<u>ADR43210</u>	<u>ADR43210</u>	<u>ADR43210</u>
0 00000	8 01000	16 10000	24 11000
1 00001	9 01001	17 10001	25 11001
2 00010	10 01010	18 10010	26 11010
3 00011	11 01011	19 10011	27 11011
4 00100	12 01100	20 10100	28 11100
5 00101	13 01101	21 10101	29 11101
6 00110	14 01110	22 10110	30 11110
7 00111	15 01111	23 10111	

**2-4.10 Serial Bus Connector.** If the receiver is configured for serial bus control using either an RS-232 or RS-422 connection, the correct connector must be used. The RS-232 interface uses a 25 pin D connector while the RS-422 interface uses a 37 pin D connector. The interfaces are configured as Data Terminal Equipment (DTE) with male pins on the chassis connector.

If connected directly to a computer interface also configured as DTE, a reversal of transmit and receive data (TXD and RXD or SD and RD) and request to send and clear to send (RTS and CTS or RS and CS) lines may be necessary. The Request to Send and Clear to Send lines may be jumpered together on the mating connector if required by the system. These reversals or jumpers are normally not required if units are connected through a modem. The pin descriptions are listed in tables 2-4 and 2-5.

**Table 2-4. RS-232 Bus Connector Pin Descriptions.**

PIN	SIGNAL	REMARKS
1	CHASSIS	Safety or shield ground
2	TXD	Transmit Data, Status data from receiver
3	RXD	Receive Data, Control data to receiver
4	RTS	Request To Send (set true from receiver)
5	CTS	Clear To Send (to rcvr, must be true)
6	DSR	Data Set Ready (to receiver, not used)
7	GROUND	Logic Ground
8	RLSD	Rcvd Line Sig Detect (to rcvr, not used)
20	DTR	Data Terminal Ready (set true from rcvr)

**Table 2-5. RS-422 Bus Connector Pin Descriptions.**

PIN	SIGNAL	REMARKS
1	CHASSIS	Safety or shield-ground
4	SD A	Send Data, Status data from receiver
22	SD B	Send Data, Status data from receiver
6	RD A'	Receive Data, Control data to receiver
24	RD B'	Receive Data, Control data to receiver
7	RS A	Request to Send (set true from receiver)
25	RS B	Request to Send (set true from receiver)
9	CS A'	Clr to Send (to rcvr, must be set true)
27	CS B'	Clr to Send (to rcvr, must be set true)
11	DM A'	Data Mode (Same as DSR)
29	DM B'	Data Mode (Same as DSR)
13	RR A'	Receiver Ready (Same as RLSD)
31	RR B'	Receiver Ready (Same as RLSD)
12	TR A	Terminal Ready (Same as DTR)
30	TR B	Terminal Ready (Same as DTR)

**2-4.10.1 Serial Bus Addressing and Configuration.** To operate the receiver under serial bus control, certain functions must be set into the receiver. All of these functions are set using the front panel keypad and display. The functions will be retained when the receiver is off.

To configure the receiver for serial bus operation set the POWER switch to ON, the rear panel REMOTE/LOCAL switch to LOCAL, and perform the Special Functions in paragraphs 3-2.3.1.16.3, 3-2.3.1.16.4, and 3-3.3.1.16.5. These procedures must be followed when initially installing the receiver for serial bus control.



## CHAPTER 3

### OPERATING INSTRUCTIONS

#### Section I. LOCAL CONTROL

**3-1 INTRODUCTION.** This chapter contains both local (manual) and remote control receiver operating instructions.

**3-2 LOCAL OPERATION.** Local (manual) operation is performed using the front panel controls and displays. Figure 1-1 and table 3-1 shows/lists the front panel controls and functions; figure 3-1 and table 3-2 shows/lists the keypad control functions; and figure 3-2 and table 3-3 shows/lists the displays and functions.

**3-2.1 Power On and Initial Set Up.** To turn on, and initially set-up the R-3050, perform the following procedures for each receiver:

1. Turn the VOLUME controls to minimum.
2. Set the LOCAL/REMOTE switch to LOCAL.
3. Set the POWER switch to ON.
4. Observe front panel display for previous parameters.
5. Speaker Operation
  - a. For normal operation (not ISB) set the SELECT switch to NORM.
  - b. To listen to the lower sideband in the ISB reception mode, set the SELECT switch to ISB/L.
  - c. Adjust the SPEAKER VOLUME control as desired.
6. Headphone Operation
  - a. For normal operation (not ISB), plug the headphone into the NORM PHONES jack.
  - b. To listen to the lower sideband in the ISB reception mode, plug the headphone into the ISB/L PHONES jack.
  - c. Adjust the NORM or ISB/L VOLUME control as desired.
7. To shut down the receiver set the POWER switch to off (down).

**3-2.2 Initial Adjustments and Control Settings.** To receive the desired signals, refer to table 3-4 and set the receiver to the recommended preliminary parameters. Further adjustment may be required depending on operator preference and propagation conditions.

**3-2.3 Normal Operation.** Receiver functions are set or changed by watching the front panel display, while using the keypad (and/or main adjustment knob) to select and enter the parameters. After a function is selected on the keypad, the main adjustment knob may be used to select the desired parameter. If a numeric key is pressed after the function is selected, the main adjustment knob is disabled and the keypad must be used to select the parameters. The selected parameter is then entered using the ENT key. When no attempt is being made to change any of the receiver functions, the receiver is known to be in the "normal state". The normal state is entered when the receiver is first powered up or CAN or ENT key is pressed. Refer to table 3-5 for the normal state display indications.

**3-2.3.1 Setting or Changing Receiver Functions.** To set or change receiver functions, refer to the following paragraphs. (Functions are in alphabetical order.)

#### NOTE

Before setting or changing each receiver function, press CAN to ensure normal state condition. The CAN key may be used to cancel data before the ENT key is pressed unless data has been changed using the main adjustment knob. (The KPAD annunciator goes off after ENT or CAN is pressed.)

#### NOTE

A quick reference is provided before each procedure. Press each key in the order given. [##] indicates a numeric entry that may be made using the main adjustment knob, or the keypad.

#### Example:

**Quick Reference:** RCL, [##], ENT.

RCL = RCL key. [##] = two digit numeric entries.  
ENT = ENT key.

**Table 3-1. Front Panel Controls.**

Control	Function
POWER	Toggle type switch/circuit breaker.
LINE LEVEL ADJ.	(Factory adjustment only on some models)
ISB/L	Screwdriver installation adjustment for rear panel line level ISB/L output
NORM	Screwdriver installation adjustment for rear panel line level NORM output
┌ VOLUME ─┐	
SPEAKER	Adjusts audio level to front panel speaker.
NORM	Adjusts volume to NORM PHONES jack. Active in all modes. (Upper sideband signal in ISB mode).
ISB/L	Adjusts volume to ISB/L PHONES jack in ISB mode only. (Lower sideband signal in ISB mode only).
SELECT	Selects normal or lower sideband in ISB mode for front panel speaker audio and light bar meter.
┌ PHONES ─┐	
NORM	Headphone jack for all modes except lower sideband in ISB mode.
ISB/L	Headphone jack for lower sideband signal in ISB mode only.
Keypad	Provides data entry of receiver parameters.
Main Adjustment Knob	Provides analog adjustment of some parameters using an optical encoder on the shaft of the knob.

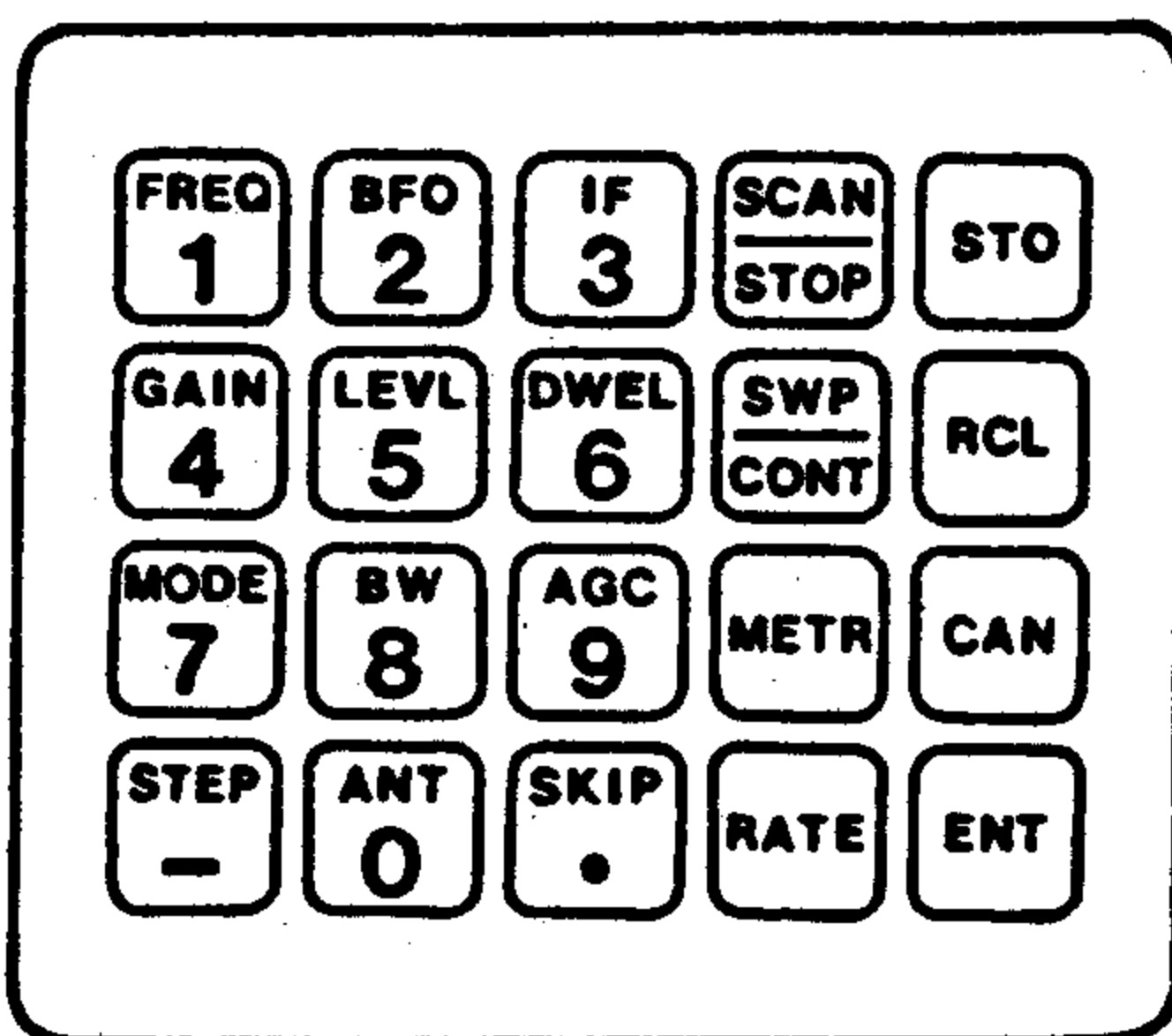

Figure 3-1. Keypad.

Table 3-2. Keypad Functions.

Key	Function
<b>FREQ</b> 1	<sup>1</sup> Allows frequency adjustment using main adjustment knob or keypad.
<b>BFO</b> 2	<sup>1</sup> Allows BFO adjustment (in CW reception mode only) using main adjustment knob, or keypad.
<b>IF</b> 3	<sup>1</sup> Allows IF frequency shift adjustment (in CW reception mode only) using main adjustment knob or keypad.
<b>SCAN</b> <b>STOP</b>	<b>SCAN:</b> Selects scan function of preset memory channels between two selected channels <b>STOP:</b> Stops scan or sweep function on current channel or frequency. Allows adjustment of receiver parameters when selected.
<b>STO</b>	Allows storage of current frequency, mode, bandwidth, AGC hold time, BFO offset, IF shift, manual gain setting, scan threshold, selected antenna, and channel skip flag in designated memory channel.
<b>GAIN</b> 4	<sup>1</sup> Allows RF gain adjustment using main adjustment knob or keypad.
<b>LEVL</b> 5	<sup>1</sup> Allows adjustment of squelch or threshold level using main adjustment knob or keypad.
<b>DWEL</b> 6	<sup>1</sup> Allows adjustment of amount of time that the receiver will stay on channels/frequencies where signals are detected in scan/sweep function using main adjustment knob or keypad.
<b>SWP</b> <b>CONT</b>	<b>SWP:</b> Selects sweep function of frequencies between two selected even and odd numbered channels. <b>CONT:</b> Continues stopped scan or sweep function from current channel or frequency.

Table 3-2. Keypad Functions-Continued.

Key	Function
RCL	Recalls stored parameters in selected memory channels for display.
MODE 7	Sequences receive mode selection.
BW 8	Sequences installed IF filters with different bandwidths.
AGC 9	Sequences AGC decay time.
METR	Sequences the signals to be displayed on bargraph meter.
CAN	Cancels current keypad operations (before ENT key press) and returns receiver to normal state. Disables main adjustment knob. Does not cancel data changed by main adjustment knob.
STEP -	<sup>1</sup> Allows setting of frequency step size for sweep function.
ANT 0	<sup>1</sup> Allows selection of antenna input jack or external antenna selection.
SKIP .	<sup>1</sup> Alternate presses toggle the skip function used during scan or sweep.
RATE	Sequences main adjustment knob frequency tuning rate to 1 kHz, 100 Hz, or 10 Hz per step. Rate indicated by brighter digit in main display when FREQ key is pressed.
ENT	Enters keypad or main adjustment knob settings and returns receiver to normal state.

<sup>1</sup>First press enables main adjustment knob. Additional press of numeric key enables keypad and disables knob.

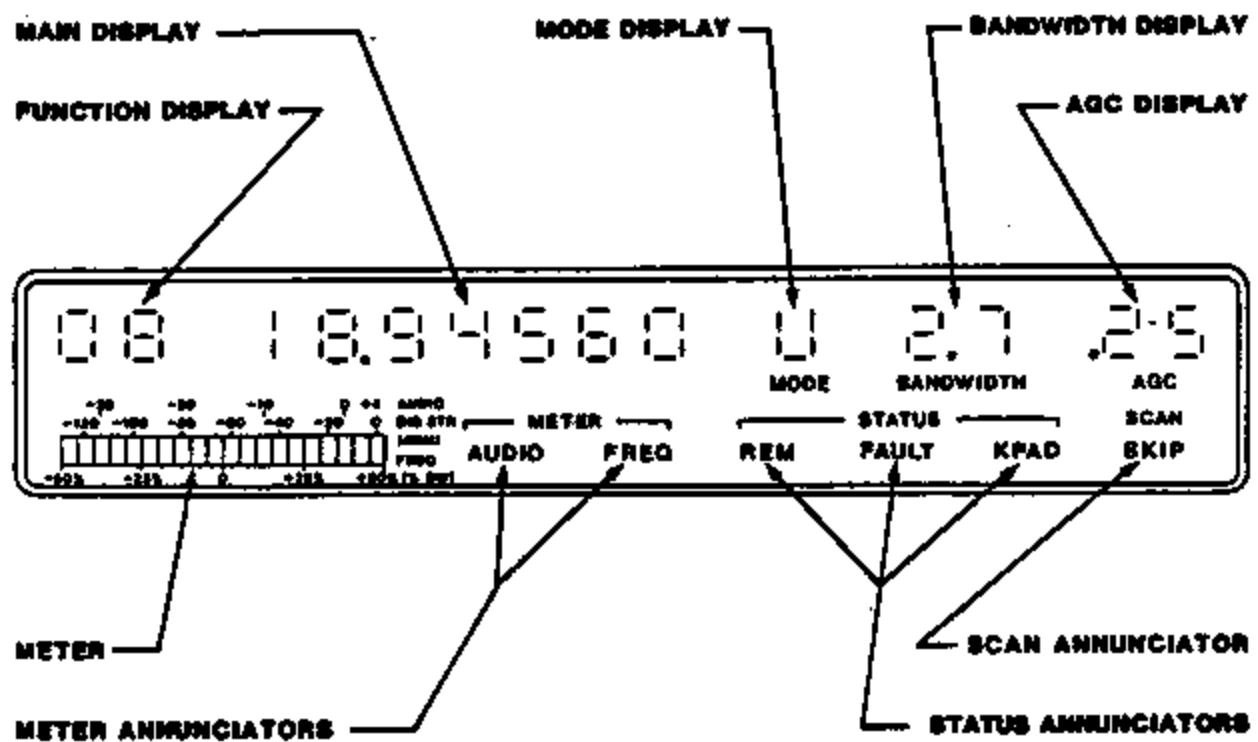

Figure 3-2. Front Panel Display.

Table 3-3. Display Functions.

Display	Function
Function	Two alphanumeric characters at left of display:
	00 - 99 Channel number
	Ad Remote control bus address
	An Antenna selection
	bd Serial bus baud rate
	bF BFO offset
	CL Clear
	d Dwell time
	Fn Function
	Fr Frequency
	GA Gain
	IF IF shift
	L Threshold level
	LP Serial bus line parameters
	OF Threshold offset
	SE Step frequency increment
	Sn Software version number
	SP Sweep memory clear
Main	Seven digits with decimal points and minus sign. Used for the following functions:
	Frequency -- Seven digits plus decimal point indicating MHz (normal display).
	BFO Offset -- Blank or minus sign and three digits. Indicates BFO offset in kHz. Displayed in CW reception mode when BFO key is pressed.
	IF Shift -- Blank or minus sign and three digits. Indicates IF passband shift in kHz. Displayed in CW reception mode when IF key is pressed.
	RF Gain -- Minus sign and three digits. Indicates RF gain in dB. Displayed when GAIN key is pressed.
	Level -- Minus sign and three digits. Indicates threshold level in dB. Displayed when LEVEL key is pressed.
	Dwell Time -- One digit. Indicates length of time in seconds during scan or sweep function that the receiver will sample the signal that has exceeded the threshold level. Displayed when DWEL key is pressed.
	Step Frequency -- Two digits and decimal point. Indicates frequency increment that the receiver will shift during sweep function. Displayed when STEP key is pressed.

Table 3-3. Display Functions-Continued.

Display	Function
Main (cont)	<p>Threshold Offset -- plus or minus sign and two digits. Indicates the magnitude of threshold offset in dB (from the level value in each memory channel) that the receiver will use during sweep or scan functions. Displayed after SWEEP or SCAN key pressed.</p> <p>Software Version -- two or three digits and decimal point. Indicates the software version installed in the receiver. Displayed when special function one is selected.</p> <p>Remote Control Bus Address -- Two decimal digits. Indicates current bus address of receiver. Displayed when special function three is selected.</p> <p>Serial Bus Baud Rate -- Three to five digits. Indicates serial bus baud rate. Displayed when special function four is selected. May be changed with STEP key.</p> <p>Serial Bus Line Parameters -- Three groups of characters: Group one is two characters representing number of data bits in one message character (7b or 8b). Group two is two characters representing number of stop bits (1S or 2S). Group three is one character representing parity selection (O = odd, E = even, and - = none). Displayed when special function five is selected. May be changed with STEP key.</p>
MODE	<p>Single character. Indicates the following receive modes:</p> <ul style="list-style-type: none"> <li>I Independent Sideband (ISB)</li> <li>L Lower sideband (LSB)</li> <li>U Upper sideband (USB)</li> <li>A Amplitude modulation (AM)</li> <li>C Continuous wave (CW)</li> <li>F Frequency Modulation (FM)</li> </ul>
BAND- WIDTH	Two digits and decimal point. Indicates approximate IF bandwidth in kHz as optionally ordered. Fixed in LSB/USB/ISB.
AGC	Two digits and decimal point. Indicates approximate AGC decay time in seconds as follows: 0.0, .25, 1.0, 3.0, off (options available). (Off = manual gain control) Fixed .05 sec. in AM reception mode.
Meter	<p>Twenty segment light bar meter. Indicates one of the following:</p> <p>Audio - When the AUDIO annunciator is on, the meter indicates audio level to the 600 Ohm line output from -34 to +4 dBm. Each segment of the display represents approximately 2 dB. Accurate only into a 600 Ohm load.</p>

Table 3-3. Display Functions-Continued.

Display	Function																													
Meter (cont)	<p>Frequency - When the <b>FREQ</b> annunciator is on, the meter indicates the approximate frequency of the signal with respect to the center of the IF bandwidth. Each segment of the display represents approximately 5% of the total IF bandwidth as follows:</p> <table border="1"> <thead> <tr> <th>Bandwidth</th> <th>Display Segment Value</th> <th>Bandwidth</th> <th>Display Segment Value</th> </tr> </thead> <tbody> <tr> <td>16.0 kHz</td> <td>800 Hz</td> <td>2.7 kHz</td> <td>135 Hz</td> </tr> <tr> <td>8.0 kHz</td> <td>400 Hz</td> <td>2.0 kHz</td> <td>100 Hz</td> </tr> <tr> <td>6.0 kHz</td> <td>300 Hz</td> <td>1.0 kHz</td> <td>50 Hz</td> </tr> <tr> <td>4.0 kHz</td> <td>200 Hz</td> <td>0.5 kHz</td> <td>25 Hz</td> </tr> <tr> <td>3.2 kHz</td> <td>160 Hz</td> <td>0.3 kHz</td> <td>15 Hz</td> </tr> <tr> <td>3.0 kHz</td> <td>150 Hz</td> <td></td> <td></td> </tr> </tbody> </table> <p>When exactly on the center frequency, the meter light segments on either side of 0 should be alternately flashing.</p> <p>RF signal strength - When both annunciators are off, the meter indicates RF signal strength from -120 to 0 dBm (when AGC display is enabled). Each segment of the display represents approximately 6 dB. When the AGC display is dark (manual gain), the main adjustment knob is used to manually control the IF gain after selecting <b>GAIN</b> [4] key. The indicator should be set to the middle of the meter scale.</p>		Bandwidth	Display Segment Value	Bandwidth	Display Segment Value	16.0 kHz	800 Hz	2.7 kHz	135 Hz	8.0 kHz	400 Hz	2.0 kHz	100 Hz	6.0 kHz	300 Hz	1.0 kHz	50 Hz	4.0 kHz	200 Hz	0.5 kHz	25 Hz	3.2 kHz	160 Hz	0.3 kHz	15 Hz	3.0 kHz	150 Hz		
Bandwidth	Display Segment Value	Bandwidth	Display Segment Value																											
16.0 kHz	800 Hz	2.7 kHz	135 Hz																											
8.0 kHz	400 Hz	2.0 kHz	100 Hz																											
6.0 kHz	300 Hz	1.0 kHz	50 Hz																											
4.0 kHz	200 Hz	0.5 kHz	25 Hz																											
3.2 kHz	160 Hz	0.3 kHz	15 Hz																											
3.0 kHz	150 Hz																													
<b>Annunciators:</b>																														
--METER--	<b>AUDIO</b>	Lights when meter displays audio level.																												
	<b>FREQ</b>	Lights when meter displays approximate frequency of the signal relative to the center of the IF bandwidth.																												
	(Off)	If both annunciators are off, meter displays RF signal strength.																												
--STATUS--	<b>REM</b>	Lights when receiver is remotely controlled.																												
	<b>FAULT</b>	Lights when fault condition exists.																												
	<b>KPAD</b>	Lights when keypad is used for data entry.																												
<b>SCAN</b>	<b>SKIP</b>	Lights when a channel/frequency is skipped during scan/sweep operations.																												

Table 3-4. Recommended Preliminary Control Settings.

SIGNAL	PARAMETERS			
	MODE <sup>1,2</sup>	BANDWIDTH <sup>3</sup>	AGC <sup>3</sup>	BFO <sup>4</sup>
AM voice	AM	4-9 kHz	fixed	Disabled
SSB voice	LSB/USB	Auto selected	.25-3.0	Disabled
SSB WB voice	CW	4-6 kHz	.25-3.0	Vary
SSB NB data	CW	.5-2.0 kHz	1.0	Vary
SSB WB data	CW	4-6 kHz	0.0	Vary
ISB	ISB	Auto selected	.25-3.0	Disabled
Morse	CW	0.3-1.0 kHz	2.0-3.0	-9.99 to 9.99 kHz
FM NB data	FM	6-16 kHz	0.0	Disabled
FSK NB data	CW	0.3 to 3.2 kHz	1.0	Vary
FSK WB data	CW	2.7 to 16 kHz	0.0	Vary
Pulse	AM	4-9 kHz	Off	Disabled

<sup>1</sup>The displayed receiver frequency (except in LSB or USB modes) is the actual center of the information band. In the LSB or USB modes, the display indicates the suppressed carrier frequency. The center of the information band is automatically shifted up or down by the receiver.

<sup>2</sup>In the CW reception mode only, the IF shift function may be used to shift the center of the bandpass up or down from the displayed frequency to reduce reception of adjacent unwanted signals.

<sup>3</sup>When using bandwidths less than 1.0 kHz, do not select an AGC decay time less than 1.0 second. When using a bandwidth between 1.0 and 2.0 kHz, do not select an AGC decay time less than 0.25 second. There are no AGC decay restrictions when using bandwidths above 2 kHz.

<sup>4</sup>The BFO is used to vary the pitch of the audio. When receiving SSB signals in the CW mode, vary the BFO until the audio is clear.

Table 3-5. Normal State Conditions.

Display	Conditions
Function	Off or memory channel number
Main	Selected frequency
MODE	Selected reception mode
BANDWIDTH	Selected bandwidth
AGC	Selected AGC
Meter	Indicating as determined by meter annunciators
Annunciators:	
--METER--	AUDIO -- Off. (On if meter indicates audio level)
	FREQ -- Off. (On if meter indicates frequency)
	(Off) -- If both annunciators are off, meter indicates RF signal strength
--STATUS--	REM -- Off in manual operation
	FAULT -- Off
	KPAD -- Off
SCAN	SKIP -- Off (On if skip flag is set)

3-2.3.1.1 *Antenna*. To select or change the antenna input jack or external antenna (option) perform the following:

Quick Reference: ANT, [ # ], ENT.

1. Press the ANT [ 0 ] key.
2. Observe "An" in function display, and current antenna selection in the main display.
3. To select the desired external antenna, use the main adjustment knob, or keypad.
4. Press ENT key to enter the data. (When using the keypad, the receiver does not change the antenna until the ENT key is pressed.)

3-2.3.1.2 *Automatic Gain Control (AGC)*. To set or change the automatic gain control decay time setting of the receiver, perform the following:

Quick Reference: AGC (Repeat).

1. Repeatedly press the AGC [ 9 ] key.
2. Observe the AGC display change. Sequence = 0.0, .25, 1.0, 3.0 seconds, and off..... or .05 and off in AM mode. Off = manual gain control (AGC decay time options available.)
3. Press the AGC key to select desired AGC.

3-2.3.1.3 *Bandwidth*. To set or change the bandwidth, perform the following:

Quick Reference: BW (Repeat).

1. Repeatedly press the BW [ 8 ] key.
2. Observe the BANDWIDTH display change as the optional bandwidth is selected. (Bandwidth is fixed in LSB, USB, and ISB.)

3-2.3.1.4 Beat Frequency Oscillator (BFO). This function can only be set in the CW reception mode, and is used to vary the tone of the audio produced by the received signal. To set or change the BFO, perform the following:

**Quick Reference:** BFO, [##], ENT.

1. Press the BFO [ 2 ] key.
2. Observe "bF" on function display.
3. Observe main display for the current BFO offset.
4. While listening for the desired CW tone, and observing the main display, adjust the main adjustment knob, or use the keypad to tune the BFO. The main display will show the BFO offset from the selected frequency. (Range = -9.99 to 9.99 kHz.)
5. Press ENT key to enter the BFO frequency. (When using the keypad to tune the BFO, the receiver does not select the new BFO frequency until the ENT key is pressed.)

3-2.3.1.5 Channel Data Recall. This function recalls all previously entered receiver parameters for a selected channel. To recall a selected memory channel, perform the following:

**Quick Reference:** RCL, [##], BFO,\* IF,\* GAIN,\*  
LEVL,\* DWEL,\* STEP,\*  
(CAN/ENT).

\* If desired.

1. Press the RCL key.
2. Observe two dashes in the function display, and the KPAD annunciator lit.
3. Select the desired channel using the main adjustment knob or the keypad. (Range = 00 to 99.)

#### NOTE

If the main adjustment knob is used to select the channel, rotate the knob counter-clockwise to select channel 00, and clockwise to select channel 01 and higher.

4. Observe selected channel number, frequency, mode, bandwidth, and AGC on display.

5. If desired, observe the main display for additional recalled channel parameters as follows: (The receiver remains set to the current parameters until the ENT key is pressed.)
  - a. Press BFO [ 2 ] key to review the BFO offset of that channel.
  - b. Press IF [ 3 ] key to review the IF shift.
  - c. Press GAIN [ 4 ] key to review RF gain.
  - d. Press LEVL [ 5 ] key to review threshold level.
  - e. Press DWEL [ 6 ] key to review dwell time.
  - f. Press STEP [ - ] key to review step size.
6. Press CAN to cancel recall of displayed data, or ENT to enter selected channel data into the receiver.

3-2.3.1.6 Channel Data Storing. This function stores all selected receiver parameters in a selected memory channel. All receiver parameters are first entered using the keypad and/or main adjustment knob. The memory channel is then selected, and all data is transferred to the memory channel. The following parameters may be stored in each memory channel: Frequency setting, Bandwidth selection, Step size setting, Dwell setting, Receive mode selection, Skip flag on or off, Threshold level setting, Manual gain setting, AGC selection and setting, BFO setting, and IF shift setting.

To store parameters in a selected memory channel, perform the following:

**Quick Reference:** (Select desired parameters, ENT),  
STO, [##].

1. Select all desired receiver parameters (frequency, mode, bandwidth, etc.) using keypad, and/or main adjustment knob. Press ENT.
2. Press the STO key.
3. Observe two dashes in the function display.

#### NOTE

The main adjustment knob is disabled in this step.

4. Press two numeric keys for desired channel (00 through 99), to select the memory channel for data entry.
5. All parameter data is stored in the indicated channel memory.

## NOTE

To clear all parameters from all memory channels refer to paragraph 3-2.3.1.16.6.

3-2.3.1.7 Dwell Time Setting. The dwell time setting is the time duration (in seconds) the receiver stays on an individual channel or frequency that has exceeded the threshold level during the scan or sweep function.

(See figure 3-3.) If the dwell time is set to zero, and the signal exceeds the threshold level, the receiver will stay on this frequency until the signal falls below the threshold. If the dwell time is set to a value other than zero, the receiver will continue the scan or sweep when the dwell time expires. The operator can stop the scan or sweep using the STOP function.

To set the dwell time, perform the following:

Quick Reference: DWEL, [#], ENT, STO, [##].

1. Press the DWEL [ 6 ] key.
2. Observe "d" in the function display and current dwell setting in the main display.
3. While observing the dwell time in the main display, adjust the main adjustment knob, or use the keypad to set the dwell time in 1-second steps. (Range = 0 to 9.)
4. Press ENT to enter dwell time.
5. Press STO, followed by the desired channel number.

3-2.3.1.8 Frequency. This function sets or changes the receiver frequency. To set or change the receiver frequency, perform the following:

Quick Reference: FREQ, [#####], ENT.

## NOTE

Repeatedly pressing the RATE key changes the brighter digit in the main display. The brighter digit indicates the tuning resolution of the main adjustment knob.

1. Press the FREQ [ 1 ] key.
2. Observe "Fr" in the function display.
3. Select the desired frequency, using the main adjustment knob or keypad. (Range = 0.00000 to 30.00000 MHz.)
4. Press ENT key to enter the frequency. (When using the keypad to select the frequency, the receiver does not tune to the new frequency until the ENT key is pressed.)

3-2.3.1.9 IF Shift. This function can only be set in CW reception mode, and is used to shift the bandpass up or down from the displayed frequency. This function helps reduce reception of adjacent unwanted signals. To set or change IF shift, perform the following:

Quick Reference: IF, [###], ENT.

1. Press the IF [ 3 ] key.
2. Observe "IF" in the function display, and current IF shift in the main display.
3. Shift the IF bandpass using main adjustment knob, or keypad. (Range -9.99 to 9.99 kHz.)
4. Press ENT to enter the IF shift. (When using the keypad to select the IF shift, the receiver does not change to the new value until the ENT key is pressed.)

3-2.3.1.10 Manual Gain. This function manually selects the IF gain of the receiver. To select manual gain, perform the following:

Quick Reference: GAIN, [###], ENT.

1. Press the GAIN [ 4 ] key.
2. Observe "GA" in the function display, and current gain setting in the main display (The AGC display goes off).
3. Select manual gain in one dB steps, using the main adjustment knob, or keypad. (Range = -127 to -000 dB.)
4. Press ENT to enter the manual gain. (When using the keypad to select the IF gain, the receiver does not change to the new value until the ENT key is pressed.)

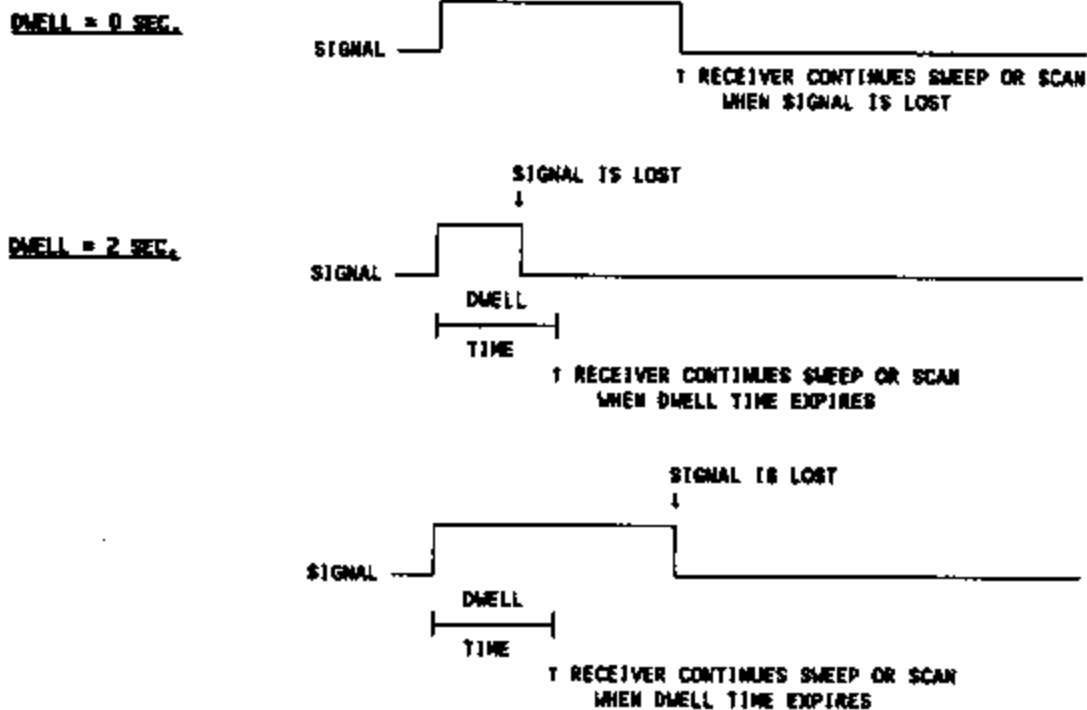

Figure 3-3. Dwell Time Examples.

3-2.3.1.11 **Meter Display.** This function is used to select the signals for meter display. The METER annunciators will change as the METR key is pressed. (If both annunciators are off the meter displays RF signal strength.) To select LSB signals for display when in the ISB reception mode, set the front panel SELECT switch to ISB/L. To select the signals for meter display, perform the following:

**Quick Reference: METR (Repeat).**

1. Repeatedly press the METR key.
2. Observe the METER annunciators change from off, to AUDIO to FREQ, and to off again. Also observe the bargraph meter indicator change.

3-2.3.1.12 **Mode.** This function selects the reception mode of the receiver. Six modes are available: Independent Sideband (ISB), Lower Sideband (LSB), Upper Sideband (USB), Amplitude Modulation (AM), Continuous wave (CW), and Frequency Modulation (FM). To select the desired reception mode, perform the following:

**Quick Reference: MODE (Repeat).**

1. Repeatedly press the MODE [ 7 ] key.
2. Observe the MODE display change as the reception mode is selected. (I=ISB, L=LSB, U=USB, A=AM, C=CW, F=FM.)

### 3-2.3.1.13 Scan Starting and Stopping.

#### NOTE

Before performing a scan function, frequencies and parameters to be sampled should be determined and set into designated memory channels.

Scan is the sequential continuous recall of each memory channel. The CPU uses data stored in each channel to select frequency, mode, bandwidth, threshold level, and all other stored parameters to operate the receiver. The receiver will stop on a frequency (for the dwell time set in that channel) when a received signal exceeds the threshold level set in the channel. If dwell time is set to zero, the receiver remains on frequency until the signal falls below threshold level, and then continues the scan. The operator may offset the threshold level from the value set in each memory channel before starting the scan.

To start/stop scanning, perform the following:

**Quick Reference:** RCL, [##], ENT, RCL, [%%], SCAN, [\*\*\*], ENT.

[##]=start channel, [%%]=stop channel, [\*\*\*]=offset.

1. Press RCL key.
2. Select desired start channel using main adjustment knob or keypad.
3. Press ENT key.
4. Press RCL key.
5. Select desired stop channel using main adjustment knob, or keypad (do not press ENT).
6. Press SCAN/STOP key.
7. Observe "OF" in function display, and threshold level offset in main display.
8. If desired, change threshold level offset with either main adjustment knob or keypad. (Range =  $\pm 30$  dB from threshold level in each channel.)
9. Press ENT to start the scan.
10. The receiver will sequentially scan from the start channel to the stop channel continuously.

**NOTE**

If the skip flag is set in a particular channel in the sequence, the receiver will immediately skip to the next consecutive channel. If the receiver stops on an unwanted signal, the SKIP key may be pressed to set the skip flag in that channel. That channel will then be skipped on the next and successive scans. (Refer to paragraph 3-2.3.1.14.)

**NOTE**

The scan initially starts at the maximum rate. The scan rate may be slowed by turning the main adjustment knob counter-clockwise. The scan rate may then be made faster (back to maximum) by turning the main adjustment knob clockwise.

11. Press the SCAN/STOP key to stop the scan.

**NOTE**

Receiver parameters may be changed with keypad and/or main adjustment

knob during stop with no affect on memory channels. Audio is enabled during stop.

12. Press the SWP/CONT key to continue the scan from stop.
13. Press the CAN key to leave the scan function during scan or stop.

**3-2.3.1.14 Skipping Channels.** This function sets or erases a skip flag in a designated memory channel. If the skip flag is set, that channel will be skipped during the scan function. The skip flag may be set or erased before the scan. The skip flag may also be set when stopped on an unwanted frequency during the scan. (Refer to paragraph 3-2.3.1.15 to skip selected frequencies for the sweep function.)

a. To store or erase the skip flag in a selected memory channel before the scan function, perform the following:

**Quick Reference:** RCL, [##], ENT, SKIP, STO, [##].

1. Press the RCL key.
2. Observe two dashes in the function display, and the KPAD annunciator lit.
3. Select the desired channel (00 through 99), using the main adjustment knob or keypad.
4. Press ENT key.
5. Observe SCAN display. (If SKIP annunciator is lit, skip flag is set. If SKIP annunciator is off, skip flag is not set.)
6. Press SKIP key to either turn SKIP annunciator on and skip the selected channel, or off to not skip the selected channel.
7. Press STO key.
8. Enter desired channel.

b. To set the skip flag in a selected memory channel during the scan function when stopped on an unwanted channel, perform the following:

**Quick Reference:** SKIP (when stopped on unwanted channel).

1. During scan when stopped on an unwanted channel, press the SKIP key.
2. Observe the SKIP annunciator light.
3. Observe the SKIP annunciator momentarily light when the channel is skipped during the next and successive scans.

**3-2.3.1.15 *Skipping Frequencies.*** The frequency skip function selects frequencies to be skipped during the sweep function. This prevents the receiver from stopping on unwanted signals on the next and successive sweep. A separate skip memory in the receiver stores up to 100 selected frequencies. (Also refer to paragraph 3-2.3.1.14 to skip selected channels in the scan function.) To store a selected frequency in the sweep skip memory, perform the following:

1. Press RCL key.
2. Observe two dashes in function display.
3. Press SKIP [ . ] key.
4. Observe "Fn" in function display.
5. Press [ 1 ] numeric key.
6. Observe "Sn" in function display, and software version number in main display.
7. Press CAN to return to the normal state.

#### NOTE

If all 100 skip memory locations contain frequencies, the next frequency stored "bumps" the first entered frequency from the skip memory. A rotating buffer ensures the first entered frequency will always be bumped out. Refer to paragraph 3-2.3.1.16.2 to clear the skip memory.

**Quick Reference:** SKIP (when stopped on unwanted frequency).

1. During sweep when stopped on an unwanted frequency, press the SKIP key.
2. Observe the SKIP annunciator light.

**3-2.3.1.16 *Special Functions.*** Special functions are available to the operator as listed in table 3-6. Each of the special functions are discussed in the following paragraphs:

**Table 3-6. *Special Functions.***

Function	Description
RCL [ . ] 1	Software version number
RCL [ . ] 2	Clear skip memory
RCL [ . ] 3	Remote Control Bus address
RCL [ . ] 4	Serial bus baud rate
RCL [ . ] 5	Serial bus line parameters
RCL [ . ] 6-0	Not used or not applicable
RCL [ . ] [ . ] 911	Clear all memory channels

**3-2.3.1.16.1 *Software Version Number.*** This function shows the installed software version number. To view the installed software version, perform the following:

**Quick Reference:** RCL, [ . ], [ 1 ], CAN.

**3-2.3.1.16.2 *Clear Sweep Skip Memory.*** This function clears all frequencies in the sweep skip memory. To clear all frequencies in the sweep skip memory, perform the following:

**Quick Reference:** RCL, [ . ], [ 2 ], ENT.

1. Press RCL key.
2. Observe two dashes in function display.
3. Press SKIP [ . ] key.
4. Observe "Fn" in function display.
5. Press [ 2 ] numeric key.
6. Observe "SP" in function display and SKIP Annunciator lit.
7. Press ENT key.

**3-2.3.1.16.3 *Remote Control Bus Address.*** This function displays or selects the remote control bus address for the receiver. To display/select the remote control bus address perform the following:

#### NOTE

Only the serial bus configured receiver bus address may be changed using the keypad. To change the IEEE-488 bus address refer to paragraph 2-4.9.1. Any remote controlled receiver may display the current bus address.

**Quick Reference:** RCL, [ . ], [ 3 ], [ ## ]\*, ENT  
\*If desired.

1. Press RCL key.
2. Observe two dashes in function display.
3. Press SKIP [ . ] key.
4. Observe Fn in function display.
5. Press [ 3 ] numeric key.
6. Observe Ad in function display, and receiver current address in main display.
7. Press CAN key to keep the current address or,

8. If desired, change the serial bus address with either the main adjustment knob or the keypad. (Range = 0 to 30.)
9. Press ENT to immediately select the new serial bus address.

7. Press CAN to keep current parameters, or;
8. Repeatedly press the STEP key.
9. Observe line parameters change in main display.
10. When correct line parameters are displayed, press ENT key.

3-2.3.1.16.4 Serial Bus Baud Rate Selection. This function allows serial bus baud rate display or selection. To display/select the serial bus baud rate, perform the following:

Quick Reference: RCL, [ . ], [ 4 ], STEP\* ENT\* CAN.

\* If desired.

1. Press RCL key.
2. Observe two dashes in function display.
3. Press SKIP [ . ] key.
4. Observe "Fn" in function display.
5. Press [ 4 ] numeric key.
6. Observe "bd" in function display, and current baud rate in main display.
7. Press CAN to keep current baud rate, or;
8. Repeatedly press the STEP key.
9. Observe baud rate change in main display.
10. When correct baud rate is displayed, press ENT key.

3-2.3.1.16.5 Serial Bus Line Parameter Selection. This function allows display or selection of serial bus parameters including: number of data bits per character, number of stop bits, parity bit on/off, and parity bit odd/even. To display/select the serial bus line parameters, perform the following:

Quick Reference: RCL, [ . ], [ 5 ], STEP\* ENT\* CAN.

\* If desired.

1. Press RCL key.
2. Observe two dashes in function display.
3. Press SKIP [ . ] key.
4. Observe "Fn" in function display.
5. Press [ 5 ] numeric key.
6. Observe "LP" in function display, and current line parameters in main display as follows:

1 or 2 stop bits  
↓  
**8b 1S 0** ← Odd, Even, or no ( - ) parity  
↑  
7 or 8 bit character

**NOTE**

Special functions 6, 7, 8, 9, and 0 are not used or not applicable.

3-2.3.1.16.6 Clear All Memory Channels. This function clears all memory channels of all entered parameters and replaces the parameters as follows:

Frequency = 10 MHz  
Bandwidth selection = (as optionally configured)  
Step size setting = 1 kHz  
Dwell setting = 0 sec.  
Receive mode selection = AM  
Threshold level setting = -127 dBm  
Skip flag on or off = off  
AGC selection and setting = on/.05 sec.  
Manual gain setting = -000 dBm  
IF shift = off, BFO = 000 kHz

**NOTE**

All previous channel parameter data will be lost when the ENT key is pressed.

To clear all the memory channels, perform the following:

Quick Reference: RCL, [ . ], [ . ], [ 9 ], [ 1 ], [ 1 ], ENT.

1. Press RCL key.
2. Observe two dashes in function display.
3. Press SKIP [ . ] key.
4. Observe "Fn" in function display.
5. Press SKIP [ . ] key.
6. Observe "CL" in function display, and (..) in main display.
7. Press numeric keys 9, 1, 1.
8. Observe (..911) in main display.
9. Press ENT key.
10. Observe (..911) flashing in main display while memory clears.

**3-2.3.1.17 Step Increment Frequency Setting.** When the sweep function is enabled, the receiver will sample a selected frequency, and then "step" to the next frequency. The step function determines the frequency increment between steps.

#### NOTE

The step increment frequency should be stored in even numbered channels. (Refer to paragraph 3-2.3.1.18.)

To select the step increment, perform the following:

**Quick Reference:** STEP, [#.#], ENT, STO, [##].

1. Press the STEP [ - ] key.
2. Observe "SE" in the function display, and current step increment frequency in the main display.
3. While observing the step increment frequency in the main display, select the step increment frequency in .1 kHz steps using the main adjustment knob, or keypad. (Range = 0.1 to 9.9 kHz.)
4. Press ENT to enter the step increment frequency.
5. Press STO key.
6. Observe two dashes in function display.
7. Select desired even numbered memory channel.

#### 3-2.3.1.18 Sweep Starting and Stopping.

#### NOTE

Before performing a sweep function, frequency bands and parameters to be sampled should be determined and set into designated memory channels.

The sweep function is used to sequentially tune between frequencies in two consecutive memory channels. The start frequency is selected by entering an even numbered channel (for example 02) containing the desired start frequency.

The stop frequency is selected by entering a higher odd numbered channel (for example 03) containing the desired stop frequency. All other parameters (threshold level, dwell time, reception mode, bandwidth, AGC, step frequency, skip flag, etc.) used during the sweep are selected from the even numbered start channel.

The step increment frequency stored in the even numbered channel determines the amount of frequency change the receiver sequentially tunes to during the sweep. When the frequency in the stop channel is reached, the receiver starts over again from the entered start channel. The frequency in the stop channel may be higher or lower than the start frequency.

If the stop channel entered is higher than the next consecutive odd numbered channel (for example 09 instead of 03 in the previous example), the receiver will sequentially tune to the frequency in the consecutive odd numbered channel (03), and then select the next consecutive even numbered channel (04). The parameters in this even numbered channel (04) are then used during the sweep to the next higher odd numbered channel (05). The sweep function continues until the final stop channel (09) is reached. The sweep then starts over again from the originally entered start channel (02).

#### NOTE

If the skip flag is set in a particular even numbered channel in the sequence, the receiver will immediately skip to the next consecutive even numbered channel.

The receiver will stop on a frequency (for the preset dwell time set in the even channel), when the signal exceeds the preset threshold level. If the dwell time is set to zero, the receiver remains on frequency until the signal falls below the preset threshold level. The operator may offset the threshold level from the value set in the even numbered start channel before starting the scan.

To start and stop the sweep function, perform the following:

**Quick Reference:** RCL, [##], ENT, RCL, [%%], SWP, [\*\*\*], ENT.

Where [##] is the start (even) channel, [%%] the stop (odd) channel, and [\*\*\*] the threshold offset.

1. Press RCL key.
2. Select the desired even numbered start channel containing the start frequency and parameters using the main adjustment knob, or keypad.
3. Press ENT key.

4. Press RCL key.
5. Select the desired odd numbered stop channel containing the stop frequency using the main adjustment knob, or keypad (do not press ENT key).
6. Press the SWP/CONT key.
7. Observe "OF" in the function display, and threshold level offset in the main display.
8. If desired, change the threshold level offset with either the main adjustment knob or the keypad. (Range =  $\pm 30$  dB from the preset threshold level in the even numbered channel(s).)
9. Press ENT to start the sweep.

**NOTE**

The sweep initially starts at the maximum rate. The sweep rate may be slowed by turning the main adjustment knob counter-clockwise. The sweep rate may then be made faster (back to maximum) by turning the main adjustment knob clockwise.

**NOTE**

If the receiver stops on an unwanted signal, the SKIP key may be pressed to skip that frequency on the next and successive sweeps. (Refer to paragraph 3-2.3.1.15.)

10. Press the SCAN/STOP key to stop the sweep.

**NOTE**

Receiver parameters may be changed with keypad and/or main adjustment knob during stop with no affect on memory channels. Audio is enabled during stop.

11. Press the SWP/CONT key to continue the sweep from stop.
12. Press the CAN key to leave the sweep function during sweep or stop.

**3-2.3.1.19 Threshold Setting.** This function is used to select the threshold level of the receiver. The setting determines the signal threshold level that will activate the audio output. The setting also determines when the receiver will stop during scan or sweep functions if stored in a memory channel. When the scan or sweep function is enabled, the receiver will stop at channel frequencies with RF signal levels higher than the threshold level set in that channel. To set the threshold level, perform the following:

**Quick Reference:** LEVL, [###], ENT.

1. Press the LEVL [ 5 ] key.
2. Observe "L" in the function display and current threshold level in the main display.
3. While observing the level in the main display, select the threshold level in one dB steps, using the main adjustment knob or keypad. (Range = -127 to 000 dB.)
4. Press ENT to enter the threshold level.

## Section II. REMOTE CONTROL

**3-3 REMOTE OPERATION USING SERIAL BUS.** The receiver may be optionally operated under remote control using a serial bus and a suitable bus controller. To operate in this manner, set the rear panel LOCAL/REMOTE switch to the REMOTE position.

If the controller takes control, the REM annunciator on the display panel will light. The LOCAL/REMOTE switch has positive control over the remote control function. However, the bus controller may allow local control or prevent local control when the switch is in the REMOTE position.

Ensure that the communications parameters are set in accordance with the system requirements. Refer to Chapter 2 for the correct installation procedures. The bus address, baud rate, number of data bits, type of parity used, and number of stop bits must match the requirements of the system controller. Refer to paragraphs 3-2.3.1.16.3, 3-2.3.1.16.4, and 3-2.3.1.16.5 to set in correct serial bus operating parameters.

**3-3.1 Serial Bus Description.** Several serial busses may be used as described in paragraph 1-3.4.3.

**3-3.2 Serial Bus Message Format.** All transmissions, in either direction, conform to the message format shown in figure 3-4.

Each character in the message is passed in an asynchronous serial format as shown in figure 3-5. The number of data bits, number of stop bits, parity options and baud rate are all selectable from the front panel of the receiver through the keypad. These selections are stored in non-volatile memory. (Refer to paragraph 3-2.3.1.16 to set or change the parameters.) All characters are in ASCII code.

**3-3.3 Serial Bus Message Types.** All messages are divided into two major categories: command messages and status messages. Each category is discussed in the following paragraphs:

**3-3.3.1 Serial Bus Command Messages.** Command messages are sent from the controller to the receiver and are subdivided into two classes as follows:

**3-3.3.1.1 Serial Bus Radio Command Messages.** Radio command messages contain commands that are passed to the receiver. They may command the receiver to change operational parameters or to report back operational status.

**3-3.3.1.2 Serial Bus Interface Command Messages.** Interface command messages contain commands that are acted upon by the communications interface in the receiver. These commands cause the interface to change modes or other parameters.

**3-3.3.2 Serial Bus Status Messages.** Status messages are sent from the receiver to the controller and are subdivided into two classes as follows:

**3-3.3.2.1 Serial Bus Radio Status Messages.** Radio status messages contain information about the operational status of the receiver. These messages are sent as a reply to radio command messages that request a status report.

**3-3.3.2.2 Serial Bus Interface Status Messages.** Interface status messages contain error status information caused by a previous command message or other source. When in the proper interface mode, the interface will respond to all command messages except ones that request an explicit status message and there are no errors.

**3-3.4 Serial Bus Message Protocol.** The interface system operates in one of three modes: normal, acknowledge, or independent. These modes are selected by sending the receiver the appropriate interface command message. Each of the three modes are discussed in the following paragraphs:

**3-3.4.1 Serial Bus Normal Mode.** In normal mode the addressed receiver processes command messages but does not acknowledge receipt to the controller. The controller can verify the command message was received without error by later requesting a status message from the receiver. This mode is used if fast processing time is required (many receivers on the bus). The controller does not have to wait for each receiver to process the message(s) before addressing another receiver.

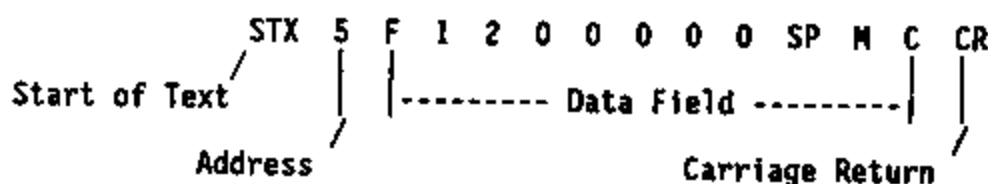

**NOTES:**

The first character of a transmission is always STX (start of text).

The second character contains the receiver address (coded in decimal). The address code for any receiver may be any digit from 0 to 7 provided that it is not used by any other unit connected to the bus. This transmission is from the controller addressed to receiver 5. The controller has no address.

The third character is the beginning of the data field. This field may contain as few as 1 or as many as 73 characters. The data field may contain one or more messages. If more than one message is contained in the data field, each message will be separated from the next by a single space (SP) character. There is no maximum number of messages that may be included in the data field provided the maximum number of characters is not exceeded. This transmission contains two messages in the data field: "F1200000" and "MC".

The last character is a CR (carriage return). This character always follows the last character of the data field.

*Figure 3-4. Serial Bus Message Format.*

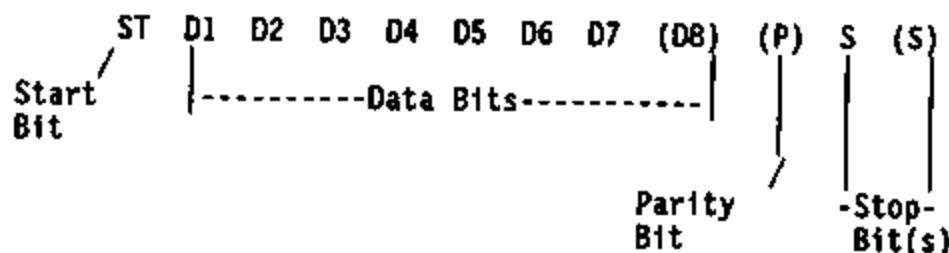

**NOTES:**

Each character contains a start bit, 7 or 8 data bits (least significant bit sent first), an optional parity bit (odd or even), and 1 or 2 stop bits. The serial baud rate may be one the following standard baud rates: 110, 150, 200, 300, 600, 1200, 2400, 4800, 9600, or 19200.

Throughput of commands may be slower than the selected baud rate to allow for message processing.

*Figure 3-5. Serial Bus Character Format.*

**3-3.4.2 Serial Bus Acknowledge Mode.** In acknowledge mode the receiver processes the command message and replies with an interface status message. If the command message contains a radio status message request (R?), and no errors or faults have been detected, the receiver replies with a radio status message. This increases processing time because the controller must wait for the reply status message before issuing another command. This mode is used when command message reception verification is required.

**3-3.4.3 Serial Bus Independent Mode.** In independent mode the receiver sends a status message whenever a pre-defined condition occurs (such as a threshold break or a fault is detected). This occurs independently of command messages. This mode should be used only in non-controller systems with a terminal or printer (unless the controller implements a method of handling contention). Several different sub-modes are possible for different pre-defined conditions.

**3-3.5 Serial Bus Message Definition.** All messages are ASCII encoded and inserted into the data field of transmissions as defined in paragraph 3-3.2. Messages from the controller may use lower or upper case for all alphabetic characters. The receiver always uses upper case.

Each message that can be sent or displayed using the bus controller is listed in the following tables:

- o Table 3-7. Serial Bus Interface Command Messages.
- o Table 3-8. Serial Bus Interface Status Messages.
- o Table 3-9. Serial Bus Radio Command/Status Messages.

#### NOTE

Radio command messages are similar to manual key press sequences. (Refer to paragraph 3-2.)

**Table 3-7. Serial Bus Interface Command Messages.**

Message	Definition
:ACKN	Set acknowledge interface mode
:IND1	Set independent mode 1
:NORM	Set normal interface mode
:?	Request interface status message

**Table 3-8. Serial Bus Interface Status Messages.**

Message	Definition
IE:IVAL	Illegal value
IE:OVFL	Interface error - buffer overflow
IE:UNKN	Interface error - unrecognized msg.
LE:PRTY	Line error - parity
LE:FRMG	Line error - framing
LE:OVRN	Line error - overrun
OK:NORM	No errors, normal mode
OK:ACKN	No errors, acknowledge mode
OK:IND1	No errors, independent mode 1
RE:FALT	Radio error - fault was detected

Table 3-9. Serial Bus Radio Command/Status Messages.

Message <sup>1</sup>	Definition
A?	Request current AGC decay time.
A*	Change receiver AGC decay time. * represents one of the following characters: Z for zero decay time, S for the shorter of the available times, M for the medium time selection, L for the longest selection, and O for AGC off (MGC). In AM mode, Z, S, M, or L will only select S time.
B?	Request current BFO setting.
B±123	Change the BFO offset. + or - sign and 1 through 3 represent the significant figures of the BFO offset with 1 representing the kHz units, 2 the 100 Hz, and 3 the 10 Hz increments. Valid in CW mode only. (Range: -999 through +999.)
C	Continue a stopped scan or sweep operation. ("SP" stops the sweep or scan.)
C?	Request parameters that are different from those reported in last radio status msg.
CL	Clear all 100 memory channels to default parameters. The receiver takes approximately 15 seconds to complete this command. No other radio command messages should be sent during this time.
D?	Request current dwell time.
D#	Change dwell time. # represents a one character number to select the dwell time after signal detection during scan or sweep operations. (Range: 0 through 9)
E?	Request current antenna selection.
E#	Change antenna selection. # represents a number from 0 - 9. (option)
F?	Request current frequency.
F1234567	Change receiver frequency. Digits 1 through 7 represent the seven digits of the receiver operating frequency with 1 representing the most significant (10 MHz digit) and 7 representing the least significant (10 Hz). (Range: 0000000 through 3000000)
G?	Request current manual gain setting.
G123	Change manual gain. Digits 1 through 3 represent the significant figures of the IF gain reduction in dB with 1 representing the 100 dB, 2 the 10 dB, and 3 the unit dB increments. Changing the manual gain turns the AGC off. (Range: 000 thru 127)
I?	Request current IF shift setting.
I±123	Change the IF shift. + or - sign and 1 through 3 represent the significant figures of the IF shift with 1 representing the kHz units, 2 the 100 Hz, and 3 the 10 Hz increments. (Range: -999 through +999)
K	Cancel the command in progress. Exits scan or sweep operations.

Table 3-9. Serial Bus Radio Command/Status Messages-Continued.

Message <sup>1</sup>	Definition
L?	Request current threshold level setting. Reply will be -127 if "SP" was sent.
L123	Change the threshold level. Digits 1 through 3 represent the signal threshold level to activate the audio circuits and stop the sweep or scan if stored in a memory channel. 1 = 100, 2 = 10, and 3 = unit increments of the threshold level in dBm. (Range: 000 through 127)
M?	Request current receive mode.
M*	Change receiver operating mode. The * represents a one character code chosen from the following set: I for ISB, L for LSB, U for USB, A for AM, C for CW, and F for FM.
O?	Request the current threshold offset.
O±123	Change the threshold offset used in scan or sweep operation. The + or - sign and 1 through 3 represent the offset value. 1 = 100, 2 = 10, and 3 = the unit increments in dBm. (Range: -030 through +030 dBm.) This function should be set before starting a sweep or scan.
P?	Request current step size.
P12	Change Step Size. 1 = 1000, and 2 = 100 hertz increment of the step size to be used in sweep operation. (Range: 00 through 99)
R? <sup>2</sup>	Request radio status message of all parameters.
RC##	Recall operating parameters from memory channel. The ## represents the two digits of the memory channel from which to recall the parameters. Recalled data is entered immediately. This command is also used to set the starting channel for a scan or sweep operation in which case it is followed by a scan or sweep command. (Range: 00 through 99)
S?	Request radio status message of the received signal strength. Reply will be "S123". Digits 1 through 3 represent the significant digits of the signal strength in dB below one milliwatt where 1 represents the 100 dB, 2 represents the 10 dB, and 3 represents the unit dB increments. (Range: 000 through 127)
SC##	Begin scan of memory channels. Where ## represents the two digits of the highest memory channel to be scanned. The scan starts at the memory channel most recently recalled. Offset should be set before sending this command. NOTE: If receiver is currently scanning or sweeping, send a "K" command before this command or the receiver will interpret this command as an "SP" command. (Range: 00 through 99)

Table 3-9. Serial Bus Radio Command/Status Messages-Continued.

Message <sup>1</sup>	Definition
SK or NSK	Skip Flag. SK sets the skip flag and NSK removes the skip flag for scan operations. During sweep operations, SK stores the current frequency in the sweep skip memory. Command must be followed by a store channel operation to be effective in a later scan or sweep.
SP	Stop the scan or sweep operation in progress but save parameters. Threshold level is temporarily set to -127 dBm. ("C" continues scan or sweep.)
ST##	Store current operating parameters into memory channel. The ## represents the two digits of the memory channel being stored to. (Range: 00 through 99)
SW##	Begin sweep of frequency bands. The ## represents the two digits of the highest odd numbered memory channel from which to take the sweep stop frequency. The sweep starts at the frequency of the channel most recently recalled with the RC## command. (Range: 00 through 99) Offset ("O") should be set first.
T	Allow local (manual) operation (enable front panel with LOCAL/REMOTE switch in REMOTE position).
W?	Request current IF bandwidth.
W#	Change receiver IF bandwidth. The # represents a one character number to select the IF bandwidth ranging from 0 for the narrowest bandwidth up to 5 for the widest bandwidth. The number of bandwidths available varies with the receiver configuration so the highest bandwidth number may be less than 5.
X	Remote control operation only (disable front panel with LOCAL/REMOTE switch in REMOTE position).

<sup>1</sup>All radio status messages (replies) use the same format as the radio command message for that parameter. For example, the reply to the radio command message "B?" (current BFO setting) is "B+123". (The same format as the radio command message to change the BFO). When more than one parameter is being reported, the individual parameters are separated by a blank (space) character.

<sup>2</sup>The following represents the reply to the R? command. Refer to the table for a definition of each character.

F1234567 B+123 I+123 G123 L123 W# A\* M\* D# P12 E# O+123 S123

**3-4 REMOTE OPERATION USING IEEE-488 BUS.** The receiver can be operated under remote control, using an IEEE-488 bus, if the optional IEEE-488 bus module, bus connector, and appropriate software is installed. To operate in the remote mode, set the REMOTE/LOCAL switch to the REMOTE position. When the switch is in the REMOTE position, the controller determines whether the receiver is in the remote or local mode.

#### NOTE

The controller can command the receiver to enter the local mode. When the controller commands the receiver to enter the local mode, the front panel REM indicator will go off.

**3-4.1 IEEE-488 Bus Description.** The IEEE-488 bus uses a party-line bus structure consisting of 16 signal lines. (Refer to table 2-3.) Devices are connected in parallel to the bus and information is passed in a byte serial/bit parallel fashion. Refer to IEEE Std 488 for a complete description of the IEEE-488 bus.

Sixteen signal lines are divided into three major functional groups: bus management lines, handshake lines, and data lines. There are five bus management lines, three handshake lines, and eight data lines. Data and message transfer is asynchronous. Devices connected to the bus may be talkers, listeners, or controller. Multiple controllers may be connected to the bus but only one controller may be in charge at a time. The controller dictates the role of the other devices by setting the ATN (attention) line true and sending the talk or listen addresses on the data lines. While the ATN line is true, all devices must listen to the data lines. When the ATN line is false, only devices that have been addressed will actively send or receive data. All others ignore the data lines.

Several listeners can be active simultaneously but only one talker can be active at a time. Whenever a talk address is put on the data lines (while the ATN is true), all other talkers will automatically be unaddressed.

The bus management lines conduct an orderly flow of information across the bus. The five bus management signals are defined in table 3-10.

Table 3-10. IEEE-488 Bus Management Signals.

Name (Mnemonic)	Description
Attention (ATN)	Causes all devices to interpret data on the bus as a controller command. When ATN is true, the bus is placed in the "Command Mode". All devices on the bus interpret data on the eight data lines as commands. When ATN is false, the bus is placed in the "Data Mode". All active listeners on the bus interpret data on the eight data lines as data.
Interface Clear (IFC)	Clears the bus. Sets the bus to an idle state.
Service Request (SRQ)	Alerts the controller to a need for communication.
Remote Enable (REN)	Enables devices to respond to remote program control when addressed by the controller.
End or Identify (EOI)	Indicates last byte of multibyte sequence.

The three handshake lines coordinate the transfer of data over the bus. Transfer is asynchronous and the transfer rate automatically adjusts to the speed of the source and acceptor. The transfer rate will be that of the slowest active device. The three handshake lines are defined in table 3-11.

Table 3-11. IEEE-488 Bus Handshake Lines.

Name (Mnemonic)	Description
Data Valid (DAV)	Sent by source to indicate that data on the bus is valid. All active devices on the bus can accept the byte as true information.
Not Ready for Data (NRFD)	Sent by acceptor to indicate that a device is not ready to accept data.
Not Data Accepted (NDAC)	Sent by acceptor to indicate that the data byte has not yet been read from the bus.

The eight bidirectional data lines (D1 - D8) transfer the data bytes on the bus. The bus management signals determine which device sends and which devices receive the byte. The handshake lines determine how long the byte remains on the bus.

One 24-pin, D-type interface connector provides parallel connection for the receiver. A maximum of fifteen devices, including the bus controller, may be connected to the bus. (Each R-3050 chassis is counted as one device.) Each receiver must have a unique address set by the rear panel switches.

The receiver may act as a talker and a listener. The SRQ function is selectable by means of a switch on the rear panel. If the SRQ function is disabled, the receiver can not request controller attention for communication. Two other switches on the rear panel are used to select the unaddressed talk only and listen only modes.

**3-4.2 IEEE-488 Bus Listen Data Sequence.** When the receiver is addressed to listen, it accepts data from the bus. This information is used to set the operating parameters of the receiver. Table 3-12 alphabetically lists the listen protocol for the receiver.

All characters are sent using ASCII code. The command sequence must be terminated with a carriage return and a line feed character. Only one command may be sent per listen data sequence (message). The R-3050 IEEE-488 interface will not hold off the NRFD handshake while it processes the command just received (that is, NRFD will go false as normal after the last byte of the message), but will set the BUSY bit (bit 3) in its serial poll response byte to indicate that it is not yet ready for another command. The bus is free to be used to control other devices on the bus during this time.

When the R-3050 is done processing the command it will clear the BUSY bit to indicate that it is ready to accept another command. If high speed control of the R-3050 is implemented, the bus controller should conduct a serial poll of the R-3050 before sending each command and proceed with sending the command only if the BUSY bit is clear.

To send multiple commands to the receiver, the controller must execute a serial poll between commands to determine the status of the receiver.

The receiver will return a status byte to the controller indicating its condition, that is, busy or not busy. The controller can check the status of the receiver by check-

ing the BUSY bit (bit 3) in the serial poll response. Refer to paragraph 3-4.4 for further information about the serial poll status byte.

Table 3-13 lists the IEEE-488 capabilities, both universal and addressed, as implemented in the receiver.

**3-4.3 IEEE-488 Bus Talk Data Sequence.** When the controller commands a receiver to talk, the receiver responds with status information. The controller specifies what operating parameter the receiver is to return. The controller command for status information is a letter followed by "?". Table 3-14 is an alphabetical list of controller status requests.

#### NOTE

Refer to paragraph 3-4.2 for radio response definitions.

**3-4.4 IEEE-488 Bus Serial Poll Status Byte.** Since the receiver automatically sets the NDAC and NRFD lines high upon receipt of commands and data, the controller must poll the receiver to send another set of commands or data to the same unit. This prevents the controller from sending data to a unit that is not actually ready to receive data even though the NRFD line is high. The status byte (in response to a serial poll) is shown in figure 3-6.

When the receiver is configured as a talker and a listener and the SRQ function is enabled, the receiver sets the SRQ line true any time the conditions enabled by the "Q##" command are true. (Refer to table 3-12.)

**3-4.5 IEEE-488 Bus Talk Only Mode.** When the unit is set to be a talker only, by the rear panel selector switch, it sends a complete status report message any time the SRQ status is set. The receiver will send the message whether sweeping, scanning, or stopped on a channel or frequency. Only one device on the bus may be a talker only. The talk only function is useful when an unaddressed printer is connected to the bus and is used for logging frequencies where activity is sensed. The talk only mode can not be used if there is a controller on the bus as a command conflict will result.

**3-4.6 IEEE-488 Bus Listen Only Mode.** When the unit is set to be a listener only, by the rear panel selector switch, the unit will respond to all messages sent on the bus regardless of address. The receiver will talk only if specifically addressed. When addressed to talk, the receiver can send status information on the bus.

Table 3-12. IEEE-488 Bus Listen Protocol.

Message	Definition
NOTE:	<sup>1</sup> Indicates leading zeros must be sent.
A*	Change receiver AGC decay time. * represents one of the following characters: Z for zero decay time, S for the shorter of the available times, M for the medium time selection, L for the longest selection, and O for AGC off (MGC). In AM mode, Z, S, M, or L will only select S time.
B±123 <sup>1</sup>	Change the BFO offset. + or - sign and 1 through 3 represent the significant figures of the BFO offset with 1 representing the kHz units, 2 the 100 Hz, and 3 the 10 Hz increments. Valid in CW mode only. (Range: -999 through +999.)
CO	Continue a stopped scan or sweep operation. ("SP" stops the sweep or scan.)
CL	Clear all 100 memory channels to default parameters. The receiver takes approximately 15 seconds to complete this command. No other radio command messages should be sent during this time.
CS	Clear the list of skip frequencies used during sweep operation.
D#	Change dwell time. # represents a one character number to select the dwell time after signal detection during scan or sweep operations. (Range: 0 through 9)
F1234567 <sup>1</sup>	Change receiver operating frequency. Digits 1 through 7 represent the seven digits of the receiver operating frequency with 1 representing the most significant (10 MHz digit) and 7 representing the least significant (10 Hz). (Range: 0000000 through 3000000)
G123 <sup>1</sup>	Change manual gain. Digits 1 through 3 represent the significant figures of the IF gain reduction in dB with 1 representing the 100 dB, 2 the 10 dB, and 3 the unit dB increments. Changing the manual gain turns the AGC off. (Range: 000 through 127)
I±123 <sup>1</sup>	Change the IF shift. + or - sign and 1 through 3 represent the significant figures of the IF shift with 1 representing the kHz units, 2 the 100 Hz, and 3 the 10 Hz increments. (Range: -999 through +999)
K	Cancel the command in progress. Exits scan or sweep operations. Does not cancel commands previously processed.
L123 <sup>1</sup>	Change the threshold level. Digits 1 through 3 represent the signal threshold level to activate the audio circuits and stop the sweep or scan if stored in a memory channel. 1 = 100, 2 = 10, and 3 = unit increments of the threshold level in dBm. (Range: 000 through 127)
M*	Change receiver operating mode. The * represents a one character code chosen from the following set: I for ISB, L for LSB, U for USB, A for AM, C for CW, and F for FM.
O±123 <sup>1</sup>	Change the threshold offset used in scan or sweep operation. The + or - sign and 1 through 3 represent the offset value. 1 = 100, 2 = 10, 3 = the unit increments in dBm. (Range: -030 through +030 dBm) This function should be set before starting a sweep or scan.

Table 3-12. IEEE-488 Bus Listen Protocol-Continued.

Message	Definition																																										
Q## <sup>1</sup>	<p>Where ## are two ASCII characters representing a hexadecimal byte between 00 and 3F to control the SRQ function activation on the bus.</p> <p>This byte masks (bit value = 0) or activates (bit value = 1) the appropriate trigger in the receiver to activate an SRQ. In other words, if the receiver faults when Bit 2=1, the receiver will activate the SRQ flag. All the bits are set (all bits = 1) during power up if the SRQ switch on the rear panel is enabled.</p> <p>When set, the bit positions represent the following functions:</p> <ul style="list-style-type: none"> <li>Bit 0 - When the receiver breaks squelch</li> <li>Bit 1 - When the receiver closes squelch</li> <li>Bit 2 - No fault to fault status change</li> <li>Bit 3 - Fault to no fault status change</li> <li>Bit 4 - Receiver switched from Local to Remote</li> <li>Bit 5 - Receiver switched from Remote to Local</li> </ul> <p>To interpret the ASCII characters, total the HEX VALUES using the following table:</p> <table style="margin-left: auto; margin-right: auto;"> <thead> <tr> <th>BIT</th> <th>HEX VALUE</th> <th>BIT</th> <th>HEX VALUE</th> </tr> </thead> <tbody> <tr> <td>5</td> <td>= 2</td> <td>3</td> <td>= 8</td> </tr> <tr> <td>4</td> <td>= 1</td> <td>2</td> <td>= 4</td> </tr> <tr> <td></td> <td></td> <td>1</td> <td>= 2</td> </tr> <tr> <td></td> <td></td> <td>0</td> <td>= 1</td> </tr> <tr> <td></td> <td style="border-top: 1px solid black;">3</td> <td></td> <td style="border-top: 1px solid black;">15*</td> </tr> <tr> <td></td> <td style="text-align: center;"> </td> <td></td> <td style="text-align: center;"> </td> </tr> <tr> <td></td> <td style="text-align: center;">(1st)</td> <td></td> <td style="text-align: center;">(2nd)</td> </tr> <tr> <td></td> <td colspan="2" style="text-align: center;">ASCII CHARACTER</td> <td style="text-align: right;">TOTAL</td> </tr> </tbody> </table> <p>* If the 2nd ASCII CHARACTER TOTAL has a value between 10 and 15, use the following table to determine the hexadecimal value:</p> <table style="margin-left: auto; margin-right: auto;"> <tbody> <tr> <td>10 = A</td> <td>13 = D</td> </tr> <tr> <td>11 = B</td> <td>14 = E</td> </tr> <tr> <td>12 = C</td> <td>15 = F</td> </tr> </tbody> </table> <p>The ASCII character in the above example would be: 3 15 = 3 F</p>	BIT	HEX VALUE	BIT	HEX VALUE	5	= 2	3	= 8	4	= 1	2	= 4			1	= 2			0	= 1		3		15*						(1st)		(2nd)		ASCII CHARACTER		TOTAL	10 = A	13 = D	11 = B	14 = E	12 = C	15 = F
BIT	HEX VALUE	BIT	HEX VALUE																																								
5	= 2	3	= 8																																								
4	= 1	2	= 4																																								
		1	= 2																																								
		0	= 1																																								
	3		15*																																								
	(1st)		(2nd)																																								
	ASCII CHARACTER		TOTAL																																								
10 = A	13 = D																																										
11 = B	14 = E																																										
12 = C	15 = F																																										
RC## <sup>1</sup>	Recall operating parameters from memory channel. The ## represents the two digits of the memory channel from which to recall the parameters. Recalled data is entered immediately. This command is also used to set the starting channel for a scan or sweep operation in which case it is followed by a scan or sweep command. (Range: 00 through 99)																																										
RD	Allows AGC voltage to be smoothly adjusted during remote frequency changes. Used for remote fine tuning or sweep.																																										

Table 3-12. IEEE-488 Bus Listen Protocol-Continued.

Message	Definition
SC## <sup>1</sup>	Begin scan of memory channels. Where ## represents the two digits of the highest memory channel to be scanned. The scan starts at the memory channel most recently recalled. Offset should be set before sending this command. NOTE: If receiver is currently scanning or sweeping, send a "K" command before this command or the receiver will interpret this command as an "SP" command. (Range: 00 through 99)
SD	Dumps AGC voltage when remote frequency changes are sent from the interface. Used for remote scan.
SE12 <sup>1</sup>	Change Step Size. The 1 represents kilohertz and the 2 represents the 100 hertz increment of the step size for sweep operation. (Range: 00 through 99)
SK or NSK	Skip Flag. SK sets the skip flag and NSK removes the skip flag for scan operations. Command must be followed by a store operation to be effective in a later scan.
SL#	Change the antenna selection (0 - 9) (option)
SP	Stop the scan or sweep operation in progress but save parameters. Threshold level is temporarily set to -127 dBm. ("CO" continues scan or sweep.)
ST## <sup>1</sup>	Store current operating parameters into memory channel. The ## represents the two digits of the memory channel being stored to. (Range: 00 through 99)
SW## <sup>1</sup>	Begin sweep of frequency bands. The ## represents the two digits of the highest odd numbered memory channel from which to take the sweep stop frequency. The sweep starts at the frequency of the channel most recently recalled with the RC## command. (Range: 00 through 99) Offset ("O") should be set first.
T	Allow local (manual) operation (enable front panel with LOCAL/REMOTE switch in REMOTE position).
W#	Change receiver IF bandwidth. The # represents a one character number to select the IF bandwidth ranging from 0 for the narrowest bandwidth up to 5 for the widest bandwidth. The number of bandwidths available varies with the receiver configuration so the highest bandwidth number may be less than 5.
X	Remote control operation only (disable front panel with LOCAL/REMOTE switch in REMOTE position).

Table 3-13. IEEE-488 Bus Capabilities.

Identification	Description/Capability
SH1	Source handshake, complete capability, no states omitted
AH1	Acceptor handshake, complete capability, no state omitted
T5	Basic talker, serial poll, talk only mode, will stop talking if addressed to listen, and no states omitted
L3	Basic listener, listen only mode, and will stop listening if addressed to talk
SR1	Service request, complete capability, no states omitted
RL1	Remote local, complete capability, no states omitted
PF0	Parallel poll not implemented
DC0	Device clear not implemented
DT0	Device trigger not implemented
C0	No controller functions implemented
E2	Tri-state data bus driver

Table 3-14. IEEE-488 Bus Controller Status Requests.

Message <sup>1</sup>	Definition
A?	Request current AGC decay time.
B?	Request current BFO setting.
D?	Request current dwell time.
F?	Request current frequency.
G?	Request current manual gain setting.
I?	Request current IF shift setting.
L?	Request current threshold level setting. Reply will be -127 if scan or sweep is stopped by "SP" command.
M?	Request current receive mode.
O?	Request the current threshold offset.
Q?	Request the SRQ control setting?
R? <sup>2</sup>	Request radio status message of all parameters.
SE?	Request the step size.
SL?	Request the current antenna number
SS?	Request radio status message of the received signal strength. Reply will be "S123". Digits 1 through 3 represent the significant digits of the signal strength in dB below one milliwatt where 1 represents the 100 dB, 2 represents the 10 dB, and 3 represents the unit dB increments. (Range: 0 through 127.)
W?	Request current IF bandwidth.

**NOTES:**

<sup>1</sup>All radio replies use the same format as the radio status request message for that parameter. For example, the reply to the radio status request message "B?" (current BFO setting) is "B\_123". (The same format as the radio command message to change the BFO.)

<sup>2</sup>The following represents the reply to the R? command. Refer to the table for a definition of each character.

F1234567 B\_123 I\_123 G123 L123 W# A\* M\* D# SE12 SL# SS123

Bit 7	6	5	4	3	2	1	0
FAULT	SRQ	NA	SQUELCH	BUSY	ERROR	REMOTE SWITCH	NA

**FAULT** - Receiver fault. Updated when receiver is given another command.

**SRQ** - IEEE-488 SRQ status. Cleared after serial poll.

**SQUELCH** - Receiver has an open squelch.

**BUSY** - Receiver is not ready for another command.

**ERROR** - Receiver did not recognize last command.

**REMOTE SWITCH** - LOCAL/REMOTE switch is in REMOTE position.

*Figure 3-6. IEEE-488 Bus Status Byte.*

## CHAPTER 4

### THEORY OF OPERATION

**4-1 INTRODUCTION.** This chapter contains a block diagram description of the receiver. The R-3050 contains four functional areas: Signal Processing, Synthesizer, Control, and Power Distribution. Each is discussed below. (See figure FO-2).

**4-2 SIGNAL PROCESSING.** The signal processing section consists of the circuits that process the incoming signal. The modules/boards in this section are the PRESELECTOR, 1ST MIXER, 2ND MIXER, 2ND IF, ISB, DETECTOR, AUDIO, and the optional Antenna Select board. Each is discussed below.

**4-2.1 PRESELECTOR Module** Eight bandpass and two low-pass filters are used to pass only selected received RF signals from the antenna. Low-pass filters are used between 0.0 and 1.6 MHz, while bandpass filters are used between 1.6 and 30.0 MHz.

The incoming signal is applied to the PRESELECTOR module where an RF detector and relay protects the filters. The detector opens the RF path if the signal level exceeds approximately one Watt. Under CPU control, a band select logic circuit selects the correct filter for the selected receive frequency. The module also contains an RF amplifier.

**4-2.2 1ST MIXER Module** The 1ST MIXER module converts the input signal to the first intermediate frequency (1ST IF) of 40.455 MHz. The input signal applied to the module is filtered through a 30 MHz low-pass filter. The filter rejects the first local oscillator (1ST LO) frequency preventing it from being radiated back out the antenna. The filter also rejects input signals at the 1ST IF and image frequencies.

The incoming RF signal is mixed with the tunable 1ST LO frequency from the OUTPUT LOOP module, producing the IF. The mixer's output is amplified and attenuated to the proper output level.

A fault detector sends a fault signal to the CPU module and lights the FAULT light on the module if the 1ST LO signal level falls below a preset level.

**4-2.3 2ND MIXER Module** The 2ND MIXER module filters and converts the 1ST IF at 40.455 MHz, to the 2ND IF at 455 kHz. The 1ST IF signal enters the module where a bandpass filter provides a bandwidth as

determined by the maximum bandwidth filter installed in the 2ND IF module. If the maximum bandwidth of the 2ND IF is 8 kHz or less, a 10 kHz filter is installed. If the maximum 2ND IF bandwidth is in the range of 8 to 20 kHz, a 20 kHz wide filter is installed.

An RF amplifier at the output of the filter, compensates for any signal loss. Gain control of the signal is provided by a PIN diode attenuator that receives the 1ST IF GAIN CTL voltage from a switch in the AUDIO module. The 1ST IF signal is then amplified before application to the mixer.

The 2ND IF of 455 kHz is produced by mixing the 1ST IF at 40.455 MHz with the 2ND LO frequency at 40 MHz. An RF amplifier is used at the output.

A fault detector sends a fault signal to the CPU module and lights the FAULT light on the module if the 2ND LO signal level falls below a preset level.

**4-2.4 2ND IF Module** The 2ND IF module contains the 6 selectable bandwidth IF filters (ranging from 0.3 to 20 kHz) and the first stage of significant gain. The amplifier before the filters provides moderate gain and is used to isolate the filters from the previous module. The filter designated for USB and LSB modes (normally between 2 and 4 kHz) is offset from the IF center frequency so it can be used in ISB mode for upper sideband. If the optional ISB module is not used, this filter may be centered on 455 kHz.

When LSB is selected, 1ST LO and BFO signals are automatically adjusted in frequency to place this filter as required with respect to the desired signal. Gain control is provided by a PIN diode attenuator controlled by the 2ND IF GAIN CTL voltage.

**4-2.5 DETECTOR Module** The DETECTOR module demodulates the 2ND IF signal, provides gain control voltages, and provides signal strength voltages for the front panel meter. The DET SEL logic signals from the CPU module select one of the three detector circuit outputs depending on the receive mode.

Two fault detection circuits compare the BFO and the 500 kHz LO signal to a preset reference. A low level of either signal enables the FAULT signal to the CPU module and lights the FAULT light on the module.

After amplification, the 2ND IF signal is sent out of the module as the 2ND IF MON signal and is also applied to the detector circuits as follows:

**4-2.5.1 *FM Detector.*** Frequency modulated signals are demodulated in the FM detector. This circuit mixes the 2ND IF signal at approx. 455 kHz with a 500 kHz LO signal. The resulting signal at approx. 45 kHz is applied to a pulse count type discriminator for demodulation.

The demodulated signal is applied to the FM video line for monitoring by external equipment regardless of the receive mode selected. When the FM mode is selected, the output is applied to the AUDIO module.

**4-1.5.2 *Envelope Detector.*** Amplitude modulated and pulse type signals are demodulated in the envelope detector. An averaging detector derives the AGC signal in the AM receive mode. In all other receive modes the output is peak detected to develop the AGC voltage. AGC HOLD logic signals from the CPU module determine the peak detected AGC hold time, and dump the AGC voltage during frequency changes.

The AGC EN signal from the CPU module selects either manual gain control (MGC) or automatic gain control (AGC). The MGC voltage from the CPU module provides either local (front panel) or remote gain control. When MGC is selected, the automatic gain control circuits are disabled.

**4-2.5.3 *Product Detector.*** Suppressed and reduced carrier signals are demodulated in the product detector. This circuit mixes the 2ND IF signal with the BFO signal which is substituted for the suppressed carrier frequency. The resultant signal is amplified and sent to the AUDIO module when selected by the logic circuits.

**4-2.6 *ISB Module*** The ISB (independent sideband) module is used for bandpass filtering, amplification, product detection, signal level detection, and automatic gain control for lower sideband (LSB) signals only when the ISB receive mode is selected.

When the ISB receive mode is selected, USB signals are detected in the DETECTOR module, and LSB signals are detected in the ISB module. However, when the LSB or USB receive mode is selected, the signal is passed through the 2ND IF and DETECTOR modules and the ISB module is not used.

The ISB module combines some of the functions of the 2ND IF and DETECTOR modules when in ISB mode.

This module contains a bandpass filter offset from the IF center of 455 kHz to pass LSB signals only. Gain controlled amplifiers are used like the 2ND IF and DETECTOR modules.

Signal detection is performed like the product detector used in the DETECTOR module using the BFO signal. An envelope detector is used to detect signal amplitude and to derive automatic gain control voltages. The amplitude modulation and frequency modulation detectors are not implemented in the ISB module.

The AGC time constant and manual gain control circuits in the ISB module are identical to the circuits in the DETECTOR module used for the same functions.

**4-2.7 *AUDIO Module*** The AUDIO module contains amplifiers and switches to select the correct audio signals for application to the 600 ohm balanced lines, headphone jack, and speaker. Additional switches select the correct signals for the front panel meter and 1st IF gain control.

Analog voltages corresponding to the signal strength sensed by the DETECTOR and ISB modules as well as an analog voltage corresponding to the frequency of the received signal (with respect to the IF center frequency) are sent to this module for selection and input to the CPU module.

Data signals from the CPU module (over the Control/Data bus) are latched into the PANEL INTERFACE module. The data signals (AF CON) select the correct analog signals for output and metering. The ISB SQ and DET SQ signals from the CPU (through the PANEL INTERFACE module) inhibit the audio outputs when the receiver is squelched. The MUTE signal from the rear panel also inhibits the audio outputs when enabled.

**4-2.8 *Antenna Select Board*** The optional Antenna Select board is available on some models. It selects one of two external antenna jacks on the rear panel. Relays on the board are controlled by two of the eight ANT SEL logic signals from the BFO module using data from the CPU. The operator selects the desired antenna using the front panel keypad. The PANEL INTERFACE module communicates the selection to the CPU over the Control/Data bus. The CPU then sends the correct data to the BFO module. When the receiver is muted, both antenna switches are deenergized disconnecting the antennas.

**4-3 SYNTHESIZER.** The synthesizer section produces the specific frequencies used for signal frequency conversion. The modules in the synthesizer section are the OUTPUT LOOP, STEP LOOP, FINE LOOP, REFERENCE & 2ND LO, and BFO. Each module uses phase-locked loop (PLL) circuits and are discussed below.

**4-3.1 OUTPUT LOOP Module** The OUTPUT LOOP module provides the 1ST LO signal to the 1st mixer. The module contains three CPU selectable voltage controlled oscillators (VCOs) operating between 40.455 and 70.455 MHz in 10 Hz steps. Each VCO is selected by the VCO SELECT data signal from the shift register in the FINE LOOP module.

The frequency of each VCO is controlled by phase locking the selected VCO to the sum of the STEP RF and FINE RF frequencies. A sample of the VCO output signal is mixed with the STEP RF signal, producing a difference frequency. The difference frequency passes through a low-pass filter (LPF) and gated to a phase detector. The phase detector compares the difference frequency with the FINE RF and develops the correction fine tune DC control voltage, keeping the selected VCO on frequency.

The wrong-side lock detector ensures that the output frequency locks up only if the VCO frequency is higher than the STEP RF signal. If the VCO frequency is lower than the STEP RF, the logic circuit will not allow the mixer output signal to pass through the gate circuit. This causes the phase detector to provide a DC correction voltage that drives the VCO to a higher frequency.

A fault detector sends a fault signal to the CPU and lights the FAULT light on the module if the loop loses phase lock.

**4-3.2 STEP LOOP Module** The STEP LOOP module provides the STEP RF signal and COARSE TUNE voltage to the OUTPUT LOOP module. The module contains three CPU selectable VCOs operating between 40.4 and 70.4 MHz in 100 kHz steps. Each VCO is selected by the VCO SELECT signal from the shift register in the FINE LOOP module.

The output frequency of the selected VCO is controlled by phase locking it to an integer multiple of the reference frequency. A synthesizer control circuit contains a counter that divides the 1 MHz reference signal by 10, producing an internal 100 kHz reference. A dual modulus prescaler circuit (divide by P), together with

two CPU controlled counters (in the synthesizer control) provide a divided VCO frequency representing the actual VCO frequency.

The divided VCO frequency and the 100 kHz reference frequency are phase compared in the synthesizer control circuit. The synthesizer control circuit develops the correction fine tune DC control voltage, keeping the selected VCO on frequency.

Serial STEP DATA from the CPU is clocked through a shift register circuit into the synthesizer control circuit. A digital-to-analog (D/A) converter operating from the shift register develops the COARSE TUNE voltage for both the step loop and output loop VCOs.

A fault detector sends a fault signal to the CPU and lights the FAULT light on the module if the loop loses phase lock.

**4-3.3 FINE LOOP Module** The FINE LOOP module provides the fine loop signal to the OUTPUT LOOP module. The module contains three VCOs operating between 55 and 154.99 MHz. A divide by 1,000 circuit produces output frequencies between 55 and 154.99 kHz in 10 Hz steps.

The output frequency of the selected VCO is controlled by phase locking the VCO to an integer multiple of the reference frequency. A synthesizer control circuit contains a counter that divides the 1 MHz reference signal by 100, producing an internal 10 kHz reference frequency.

A dual modulus prescaler circuit (divide by P), together with two CPU controlled divide counters (in the synthesizer control), provide a divided VCO frequency representing the actual VCO frequency.

The divided VCO frequency and the 10 kHz reference frequency are phase compared in the synthesizer control circuit. The synthesizer control develops the correction fine tune DC control voltage, keeping the selected VCO on frequency.

Serial FINE DATA from the CPU controls the divider circuits. The data is clocked through a shift register which also selects the fine, step, and output loop VCOs.

A fault detector sends a fault signal to the CPU and lights the FAULT light on the module if the loop loses phase lock.

**4-3.4 REFERENCE & 2ND LO Module** The REFERENCE & 2ND LO module provides the 1 MHz reference signal to the BFO, STEP LOOP, and FINE LOOP modules, and the 40 MHz 2ND LO signal to the 2ND MIXER module. The 1 MHz reference signal is either produced internally using an internal temperature compensated crystal oscillator (TCXO), or using an external reference. A rear panel switch selects either the internal or external frequency standard. The signal on the REF OUT jack may be used as the external frequency standard for other receivers if desired.

**NOTE:** Two different module designs are available using either a 1 MHz or a 10 MHz external reference.

The TCXO or external reference is split for application to the BFO and FINE LOOP modules. The 1 MHz reference frequency is applied to the STEP LOOP module through the BFO module.

The 40 MHz 2ND LO signal is developed by multiplying the output of a 20 MHz voltage controlled crystal oscillator (VCXO) by 2. A sample of the VCXO signal is divided by 20 and compared with the 1 MHz reference. A phase comparator compares the two frequencies and develops a DC correction voltage to keep the VCXO on frequency.

A fault detector sends a fault signal to the CPU and lights the FAULT light on the module if the reference frequency amplitude falls below a preset level.

**4-3.5 BFO Module** The BFO (beat frequency oscillator) module provides: (1) A variable RF signal used to develop an audio signal from suppressed carrier or CW transmissions for the product detector circuits, (2) A 500 kHz LO frequency used in the FM Detector circuits, (3) Buffering and amplification of the 1 MHz reference signal for use by the STEP LOOP module, and (4) Antenna select circuits.

The BFO frequency is generated by a voltage controlled oscillator (VCO) with a frequency range between 44.501 and 46.499 MHz in 1 kHz steps. The frequency of the BFO is controlled by the BFO DATA serial input clocked in from the CPU. The data is latched into the module by the SYN EN logic signal. This data also selects one-of-eight antenna select outputs to the rear panel connector or the optional Antenna Select board.

The VCO output is divided by 100 to generate BFO frequencies between 445.01 and 464.99 kHz in 10 Hz steps. The signal is amplified and applied to the product

detector in the DETECTOR and ISB modules for use when USB, LSB, ISB, or CW modes are selected.

The output frequency of the VCO is controlled by phase locking the VCO to an integer multiple of the reference frequency. A synthesizer control circuit contains a counter that divides the 1 MHz reference signal by 1000, producing an internal 1 kHz reference frequency.

A dual modulus prescaler circuit (divide by P), together with two CPU controlled divide counters (in the synthesizer control), provide a divided VCO frequency representing the actual VCO frequency.

The divided VCO frequency and the 1 kHz reference are phase compared in the synthesizer control circuit. The synthesizer control circuit develops a DC control voltage selecting the VCO frequency.

A fault detector sends a fault signal to the CPU and lights the FAULT light on the module if the loop loses phase lock.

**4-4 CONTROL** The control section of the receiver performs the following functions: interface to the optional remote control bus, synthesizer control, receiver band and bandwidth selection, AGC/MGC selection, detector selection, fault detection, front panel control interpretation, channel parameter storage, and front panel display control. The control section includes the CPU module, PANEL INTERFACE module, Front Panel Display board, front panel controls, and the optional remote control bus module and bus connector board. Each is discussed in the paragraphs below.

**4-4.1 CPU Module** The CPU module controls all receiver functions using resident software and data from the front panel controls or the optional remote control bus.

The module contains: (1) The microprocessor, (2) Erasable programmable read-only memory (EPROM) containing the software program, (3) Random access memory (RAM) used for temporary registers and calculations, (4) The analog-to-digital (A/D) converter used to convert the analog signals from the audio board into digital signals to control the front panel meter, squelch, and signal strength reporting, (5) The digital-to-analog (D/A) converter providing manual gain control, (6) The port expander providing data to the modules, and (7) A Control/Data bus connecting all devices.

**4-4.1.1 Data Flow.** The CPU module accepts control and data information directly from the PANEL INTERFACE module or the optional remote control module, depending on the position of the LOCAL/REMOTE switch. Data is transferred between the modules on the Control/Data Bus which extends into the CPU module. Under resident software control, the microprocessor sends the correct control logic signals to the output ports, the D/A converter, and the PANEL INTERFACE module.

**4-4.1.2 Input/Output.** The output ports provide the data outputs to the other receiver modules. Outputs include:

**BAND CONT** - selects correct preselector filter

**BW CONT** - selects IF filter in 2ND IF module

**AGC HOLD** - selects AGC hold time and dumps AGC during frequency changes

**DET SEL** - selects receive mode by selecting correct detector in DETECTOR module

**AGC EN** - selects either AGC or MGC

**SYN EN** - latches data into modules at correct time.

**SYN CLK** - clocks each serial data bit into modules.

**STEP DATA, FINE DATA, and BFO DATA** - synthesizer frequency control.

The D/A converter provides the analog manual gain control voltage to the DETECTOR and ISB module. The A/D converter accepts analog voltages from the DETECTOR module through the AUDIO module. Through the A/D converter the CPU can read AGC voltage (SIG STR), audio output level, and frequency error voltage.

Module fault signals are detected by the CPU module. When a fault is detected, the microprocessor signals the external bus controller over the optional remote control bus, and sends a signal to the Display board to light the front panel FAULT light.

**4-4.2 PANEL INTERFACE Module** The PANEL INTERFACE module provides buffering and data exchange between the CPU module and the front panel of the receiver. It contains: (1) latches and display drivers to operate the front panel displays and control the audio outputs, (2) input circuits for the keypad, main adjustment knob shaft encoder, and LOCAL/REMOTE switch, (3) non-volatile channel memory to store channel parameters and other parameters, (4) non-volatile temporary memory to store all front panel display parameters when power is turned off.

The front panel input circuits accept control data from the adjustment knob shaft encoder and keypad when the LOCAL/REMOTE switch is in the LOCAL position. The MUTE signal (some models) from the rear panel is also applied to the input circuits. The data are transferred to the CPU module over the Control/Data bus for processing.

Data from the CPU module over the Control/Data bus are applied to latch circuits. The data is then applied to the Display board to drive the proper display elements. Additional data is applied to the AUDIO module to select the correct audio signals (AF CON) and squelch the audio output (ISB SQ and DET SQ).

**4-4.3 Display Board** The Front Panel Display board contains light display elements plus the digit and segment select drivers. Display data from the PANEL INTERFACE module is applied to the display elements to drive the appropriate LED segment or annunciator on the board.

**4-4.4 IEEE-488 Bus Interface Module** The optional IEEE-488 Bus interface module contains its own microprocessor and program memory to interface with the control bus. Two output ports are also included that are read by the microprocessor in the CPU module as memory locations. The IEEE-488 Bus Interface module handles all handshaking on the bus without disturbing the operation of the CPU.

**4-4.5 IEEE-488 Bus Connector Board.** The optional IEEE-488 Bus Connector board contains the bus configuration switches and connects the external bus connector with the IEEE-488 Bus Interface circuits through a ribbon cable. This board is only used when the optional IEEE-488 INTERFACE module (and appropriate software) is installed.

A bus configuration DIP switch contains eight small switches accessible on the rear panel. The operator may select one of thirty-one addresses using the A0 - A4 switches. Three additional switches set the listen only, talk only, and SRQ enable bus functions.

**4-4.6 SERIAL Bus Interface Module** The optional Serial Bus interface module is very similar to the IEEE-488 bus interface module in that it has its own microprocessor and program memory. This module uses a serial receiver-transmitter integrated circuit instead of the bus control integrated circuit used in the IEEE-488 module.

**4-4.7 Serial Bus Connector Board.** The optional Serial Bus Connector board provides signal level conversion and data buffering between the SERIAL INTERFACE module and the external remote control bus.

**4-5 POWER DISTRIBUTION.** The power distribution section includes: The POWER SUPPLY module, the AC Line Filter board, and the associated wiring to the units requiring power. Voltages are distributed to the modules through the motherboard. A separate +8V output and return is distributed by dedicated motherboard circuit tracks to the Display board.

**4-5.1 POWER SUPPLY Module** The POWER SUPPLY module contains the circuits necessary to supply +8, +16, and -16 VDC to the receiver modules. A rotary switch on top of the module allows selection of either 110 or 220 VAC input power. Fault detector circuits send a fault signal to the CPU and light the FAULT light on top of the module if any of the voltages fall below a preset level.

**4-5.2 AC Line Filter Board** The AC Line Filter board keeps internally generated power supply switching noise off the AC input line. When the front panel POWER switch/circuit breaker is set to ON, input power is applied to the POWER SUPPLY module through this board.

## CHAPTER 5

## MAINTENANCE INSTRUCTIONS

## Section 1. PREVENTIVE MAINTENANCE

**5-1 INTRODUCTION.** This chapter contains both preventive and corrective operational level maintenance instructions. The information includes cleaning and lubrication, inspection, performance verification, troubleshooting, and module replacement.

**5-2 CLEANING AND LUBRICATION.** Clean the external surfaces and front panel of the unit every 2 weeks using a vacuum cleaner or small soft brush to remove any dirt or dust. Do not use any cleaning agents. There are no lubrication requirements.

**5-3 INSPECTION.** If the unit is faulty or suspected to be faulty perform a visual inspection as follows:

**5-3.1 External Inspection.**

1. Check the front panel for physical damage.
2. Check the external case and slides for physical damage.
3. Check the rear panel for physical damage.
4. Check all rear panel connectors for corrosion.
5. Check rear panel power cable for frayed or broken wires.

**5-3.2 Internal Inspection.**

**WARNING**

When the top cover is removed, high voltage may be present at the rear panel POWER connector, the AC Line Filter board, and the front panel POWER switch connections. Use caution when working in these areas.

**CAUTION**

Before removing the bottom cover, ensure the front panel POWER switch is off. Equipment damage may occur if tools or metal objects are allowed to come in contact with receiver components.

1. Remove the top and bottom covers of the unit using a no. 2 Phillips screwdriver. Push down,

and turn all captive fasteners on the covers 1/4 turn counter-clockwise.

2. Check for loose modules and circuit boards.
3. Check suspected internal connectors for corrosion or burn marks.
4. Check all cables and wiring for frayed or broken wires.

**5-4 PERFORMANCE VERIFICATION.**

Performance verification should be performed quarterly as described in the following paragraphs.

**5-4.1 Receiver Sensitivity.** This procedure verifies that the receiver's signal sensitivity is at least 10 dB above the noise threshold. To check the sensitivity of the receiver perform the following procedures:

1. Turn off power.
2. Loosen four screws holding chassis in mounting rack assembly.
3. Slide chassis drawer to fully extended position.
4. Connect RF signal generator to antenna jack.
5. Turn on and set RF signal generator output for a CW signal of 12.126 MHz at -116 dBm.
6. Connect voltmeter to 600 ohm AUDIO connector, pins L and M on rear panel. Turn on voltmeter.
7. Ensure the receiver is in LOCAL mode. Turn on receiver power.
8. Set the receiver frequency to 12.125 MHz in USB (upper sideband) reception mode.
9. Turn off receiver AGC and set receiver GAIN to -000 on front panel display.
10. Record voltmeter reading and establish reference on meter.
11. Remove CW signal input to the receiver.
12. Voltmeter should read at least 10 dB less than the reading obtained in step 10.
13. Turn off power.
14. Disconnect test equipment.
15. Return front panel controls to their normal positions.
16. Slide chassis drawer back into mounting rack assembly. Insert and tighten four screws holding drawer in place.
17. Turn on power. Return unit to normal configuration.

## Section II. CORRECTIVE MAINTENANCE

**5-5 TROUBLESHOOTING.** Corrective maintenance procedures are limited to isolation and replacement of faulty modules. No internal adjustments or component replacement should be performed at the operational level. These functions should be performed at the factory or an authorized repair depot.

Perform equipment troubleshooting in the following order:

1. Fault identification.
2. Initial checks.
3. Fault light interpretation.
4. Signal tracing (if required)
5. Module replacement.

Refer to the following paragraphs for details:

**5-5.1 Fault Identification.** A fault is usually indicated by the FAULT lamp lighting on the front panel display, or by the receiver not detecting a known good signal. If a fault is detected, the front panel FAULT lamp and the individual module fault LEDs may further isolate the fault.

**5-5.2 Initial Checks.** Before detailed troubleshooting, perform the following:

1. Check that the displays on the front panel are on, and the POWER switch is in the ON position. If the front panel displays are off, and the POWER switch is set ON, ensure that input power is correct.
2. Check operation in both LOCAL and REMOTE if optionally configured.
3. Check that valid frequency, bandwidth, and other parameters are correctly set.
4. Check for correct external reference frequency. If an external reference frequency is used, try switching to the internal reference frequency (S1 to INT) and recheck the receiver.
5. Using the keypad, perform the following initialization routine:

### NOTE

All channel data and frequency skip data will be cleared in the following steps.

- a. Press RCL, [ . ], [ . ], 9, 1, 1, ENT.
- b. Press RCL, [ . ], 2, ENT.
- c. Press RCL, 0, 0, ENT, RCL, 0, 1, SCAN, 0, 0, ENT, CAN.
- d. Press RCL, 0, 0, ENT.
- e. Momentarily set the POWER switch to off and then to ON.

**5-5.3 Fault LED Interpretation.** Modules that produce or use internally generated signals are monitored for faults. A fault LED on the top of these modules lights indicating a fault in the module. The modules with fault detectors are: POWER SUPPLY, 1ST MIXER, 2ND MIXER, DETECTOR, ISB, BFO, STEP LOOP, OUTPUT LOOP, FINE LOOP, and REFERENCE & 2ND LO.

### NOTE

Most module fault LEDs will normally flash and go out, when the receiver is powered-up.

If a front panel FAULT lamp remains on for more than a few seconds after power-up, remove the top cover of the receiver using the following procedures:

### WARNING

When the top cover is removed, high voltage may be present at the rear panel power connector, the AC Line Filter board, and the front panel POWER switch connections. Use caution when working in these areas.

1. Using a no. 2 Phillips screwdriver, push down, and turn all captive fasteners on the top cover 1/4 turn counter-clockwise.
2. Remove the top cover.
3. Check the LEDs on top of the modules to determine if one or more are on.
  - a. If only one fault LED is on, refer to paragraph 5-5.3.1.
  - b. If more than one fault LED is on, refer to paragraph 5-5.3.2
  - c. If no fault LEDs are on, refer to paragraph 5-5.3.3

**5-5.3.1 One Fault LED On.** If only one fault LED is on, the failure is usually in the indicated module. A wiring failure or a failure in the output of another module connected to the indicated module, may give a false indication. Table 5-1 lists and identifies possible failures and alternate possible failed module(s).

**5-5.3.2 Multiple Fault LEDs On.** If multiple fault LEDs are on, refer to table 5-2 to aid in module isolation.

**5-5.3.3 No Fault LEDs On.** If no fault LEDs are on, the fault may be in a module with no fault detector, or in a circuit in any module that is not monitored for faults. The modules/boards without fault detectors are: PRESELECTOR, AUDIO, 2ND IF, CPU, PANEL INTERFACE, Bus Connector, Display, Motherboard, and Line Filter. A failure of the receiver at all frequencies, and bandwidths could be caused by a failure in any of the above modules. Certain partial failures, can be isolated using table 5-3.

**5-5.4 Signal Tracing.** If the failed module or board cannot be isolated using the initial check or fault LED interpretation, isolate the failed component using signal tracing techniques. Refer to chapter 4 for signal flow descriptions.

Signals are checked at various locations in the unit using a signal generator and oscilloscope. The REF OUT, 1ST IF MON, 2ND IF MON, ISB MON, AGC, and audio outputs may be checked on the rear panel monitor connectors. Table 5-4 lists typical signals at the rear panel monitor jacks. RF signals may be checked by removing the module where the signal in question terminates, and checking the signal at the RF coaxial cable in the chassis. To reach power and control signal voltage check points on the motherboards, remove the bottom cover of the chassis.

## 5-6 MODULE REPLACEMENT.

### CAUTION

Turn off power before removing or replacing modules. Equipment damage may occur if modules are removed or replaced with power applied.

To remove and replace a module, perform the following procedures:

### 5-6.1 Removal.

1. Using a no. 2 Phillips screwdriver, push down and turn the captive fasteners on the module base 1/4 turn CCW to release the fasteners.

### CAUTION

Do not use a sharp tool to pry up the module. The module may be scratched or marred. Use a small wood or plastic pry-bar.

2. Pry up on the top edge of the module to lift the module from the receiver.

### 5-6.2 Replacement.

### NOTE

A short, diagonal black stripe on top of each module shows the correct module location in the chassis. When all modules are installed in their correct locations, the short diagonal stripes form a long continuous diagonal stripe.

1. Identify and orient the module to align the connectors on the bottom of the module with the connectors in the chassis.

### CAUTION

Ensure the module connector is aligned correctly with the connector in the chassis or the connectors may be damaged. On modules with both a coaxial cable connector and a standard connector, mate the standard connector first and then the coaxial connector.

2. Press the module firmly down to seat the connectors.
3. Using a no. 2 Phillips screwdriver, press down firmly, and turn the captive fasteners 1/4 turn clockwise until they lock.

**5-6.3 Reassembly.** When all modules have been replaced, install the top cover as follows:

1. Orient and place the top cover on top of unit.
2. Using a no. 2 Phillips screwdriver, press down firmly, and turn the captive fasteners 1/4 turn clockwise until they lock.

Table 5-1. Fault Isolation - One Fault LED.

Fault LED On	Possible Failure	Suspect Module(s)
1ST MIXER	Loss of 1ST LO signal	OUTPUT LOOP, 1ST MIXER
2ND MIXER	Loss of 2ND LO signal	REF & 2ND LO, 2ND MIXER
DETECTOR	Loss of BFO or 500 kHz LO	BFO, DETECTOR
OUTPUT LOOP	Loss of phase lock	OUTPUT, STEP, FINE LOOP
STEP LOOP	Loss of phase lock	STEP LOOP, REF & 2ND LO
FINE LOOP	Loss of phase lock	FINE LOOP, REF & 2ND LO
REFERENCE & 2ND LO	Loss of ref signal	REF & 2ND LO
ISB	Loss of BFO ISB signal	ISB, BFO
BFO	Loss of phase lock or reference signal	BFO, REF & 2ND LO
POWER SUPPLY	Wrong voltage/current	Line Filter, pwr source

Table 5-2. Fault Isolation - Multiple Fault LEDs.

Fault LEDs On	Suspect Module
2ND MIXER and REF & 2ND LO	REF & 2ND LO
OUTPUT LOOP and STEP LOOP	STEP LOOP
OUTPUT LOOP and FINE LOOP	FINE LOOP
REF & 2ND LO, FINE LOOP, STEP LOOP, OUTPUT LOOP, BFO, and ISB	REF & 2ND LO, Ext. Freq. standard, INT/EXT ref sw

Table 5-3. Fault Isolation - No Fault LEDs.

Symptoms Of Failure	Suspect Module(s)
No Display	PWR SUPPLY, Display board, PANEL INTFC.
Completely inoperative	CPU, POWER SUPPLY
Inoperative on one band	PRESELECTOR, CPU
Inoperative on one bandwidth	2ND IF, CPU
Inoperative on one mode	DETECTOR, CPU
Meter inoperative	DETECTOR, CPU, PANEL INTFC, Audio board
No audio, detector, and IF outputs	PRESELCTR, 1ST MIXER, 2ND MIXER, 2ND IF
No audio output only	DETECTOR, Audio board
No detector output only	DETECTOR
No USB or LSB on AUDIO connector	ISB, DETECTOR
No FIXED AUDIO on AUDIO connector	Audio Board, DETECTOR

Table 5-4. Typical Rear Panel Monitor Signals.

SIGNAL IN ANT		TEST POINT <sup>1</sup>	CORRECT OBSERVATION <sup>2</sup>	SUSPECT MODULE IF NOT CORRECT
0.000	NONE	1st IF MON	300 mv p-p, 40.455 MHz	1st IF Module
10 MHz	NONE	1st IF MON	50 mv p-p, 50.455 MHz	1st IF Module
10 MHz	-10 dBm	1st IF MON	250 mv p-p, 40.455 MHz	Preselector, 1st IF
10 MHz	-10 dBm	2nd IF MON	600 mv p-p, 455 kHz	1st IF, 2nd IF, Det.
10 MHz	-100dBm	2nd IF MON	600 mv p-p, 455 kHz	Detector Module

**NOTES:**

<sup>1</sup>Test points terminated with 50 ohms.

<sup>2</sup>All levels measured with receiver in AM mode, 6 kHz bandwidth, and the AGC set to .05 seconds.

**(This Page Intentionally Left Blank)**

## CHAPTER 6

### PREPARATION FOR RESHIPMENT

**6-1 INTRODUCTION.** This chapter contains information to prepare the equipment for reshipment including disassembly and removal from the rack mount, packaging, and shipping.

**6-2 DISASSEMBLY AND REMOVAL.** To disassemble and remove the receiver from the rack mount, perform the following procedures:

1. Ensure the POWER switch is set off (down).
2. Disconnect the AC power cable from the power source.
3. Disconnect all cables from the rear panel.

#### CAUTION

Do not support the weight of the unit by the front panel alone. The chassis may bend or warp. Use chassis slides or a suitable support shelf.

4. Remove the receiver from the rack mount.
5. Remove slides if installed.

### 6-3 PACKAGING.

#### NOTE

The receiver should be packed in the original shipping container if available.

To package the equipment for reshipment perform the following steps:

1. Ensure that there is sufficient foam packing material in the shipping container to protect the unit from any hard impact.
2. Cover the unit with foam or bubble-type packing material.
3. Place the unit in the center of the shipping container.
4. If using a cardboard packing carton, securely tape the seams of the carton's top cover, bottom cover, and side flaps with reinforced packing tape.
5. Attach labels or stamp in indelible ink the word FRAGILE on the top, bottom, and all sides of the container.

**6-4 SHIPPING.** There are no special shipping requirements for the equipment. Commercial or military shipping services may be used.

**(This Page Intentionally Left Blank)**

## CHAPTER 7

### STORAGE

**7-1 INTRODUCTION.** This chapter contains information for storage of the equipment including environmental conditions and any special preservation requirements.

**7-2 STORAGE ENVIRONMENT.** The receiver should be stored indoors in the original shipping container (or similar container) as described in chapter 6. The environment should be dry with a temperature range between  $-40$  to  $+70^{\circ}\text{C}$ .

**7-3 PRESERVATION.** There are no special coverings or preservation materials required to store the receiver.

## STORAGE

**7-3 PRESERVATION.** There are no special coverings or preservation materials required to store the receiver.

**7-1 INTRODUCTION.** This chapter contains information for storage of the equipment including environmental conditions and special preservation requirements.

**7-2 STORAGE ENVIRONMENT:** The receiver should be stored indoors in the original shipping container (or similar container as described in chapter 6). The environment should be dry with a temperature range between  $-40$  to  $+30^{\circ}\text{C}$ .

(This Page Intentionally Left Blank)

## CHAPTER 8

### REPLACEABLE PARTS

**8-1 INTRODUCTION.** Table 8-1 lists the modules, boards, and components available at the operational maintenance level. Board level components are normally replaced only at the depot maintenance level and are not listed in this manual. Part numbers listed are assigned by the manufacturer, Cubic Communications Inc. Ensure dash number following the number on some parts is included when ordering parts (i.e. 2541-1114-18).

*Table 8-1. Replaceable Parts List*

Description	Part Number	Remarks
Assy, Circuit Breaker	2541-1121	
Assy, Front Plate	2541-1101	Complete with display.
Assy, IEEE-488 Bus Conn Plate	2541-1124	
Assy, Rear Plate	2541-1119	
Assy, RS-232 Connector Plate	2541-1129	
Assy, RS-422 Connector Plate	2541-1125	
Assy, Shaft Encoder	2140-1122	
Board, AC Line Filter	2861-2020	Replaces 2140-2063
Board, Antenna Select	2541-2011	
Board, Display	2140-2016	
Board, Front Panel Control	2541-2003	
Board, Output IF Converter	2143-2001	
Coax Conn Plate IF	2541-1122	
Coax Conn Plate RF	2541-1126	
Display Filter	2142-1506	
Keyboard	173-012	Keypad overlay also required
Keypad Overlay	180-007	Apply to keypad
Knob, large	211-095	Adjustment knob
Knob, small	211-096	Volume control
Module, Audio	2541-1111	Fixed line level
Module, BFO	2541-1109	
Module, CPU less Program	2541-1130	Program version must be specified
Module, Detector	2541-1113	
Module, Fine Loop	2541-1106	
Module, First Mixer	2541-1116	
Module, IEEE-488	2541-1104	
Module, ISB	2541-1112	Optional filter must be specified
Module, Output Loop	2541-1107	
Module, Panel Interface	2541-1102	
Module, Power Supply	2541-1118	
Module, Preselector	2541-1117	Either 2541-2005 or 2861-2014 board
Module, Reference & 2nd LO	2541-1105	1 MHz Reference, oscillator must be specified
Module, Reference & 2nd LO	2541-1123	10 MHz Reference, oscillator must be specified
Module, Second IF	2541-1114	Optional filters must be specified
Module, Second Mixer	2541-1115	Optional filter must be specified
Module, Serial Bus	2541-1110	
Module, Step Loop	2541-1108	
Phones Jack	342-035	
Switch, Toggle	172-081	Remote/local

(This Page Intentionally Left Blank)







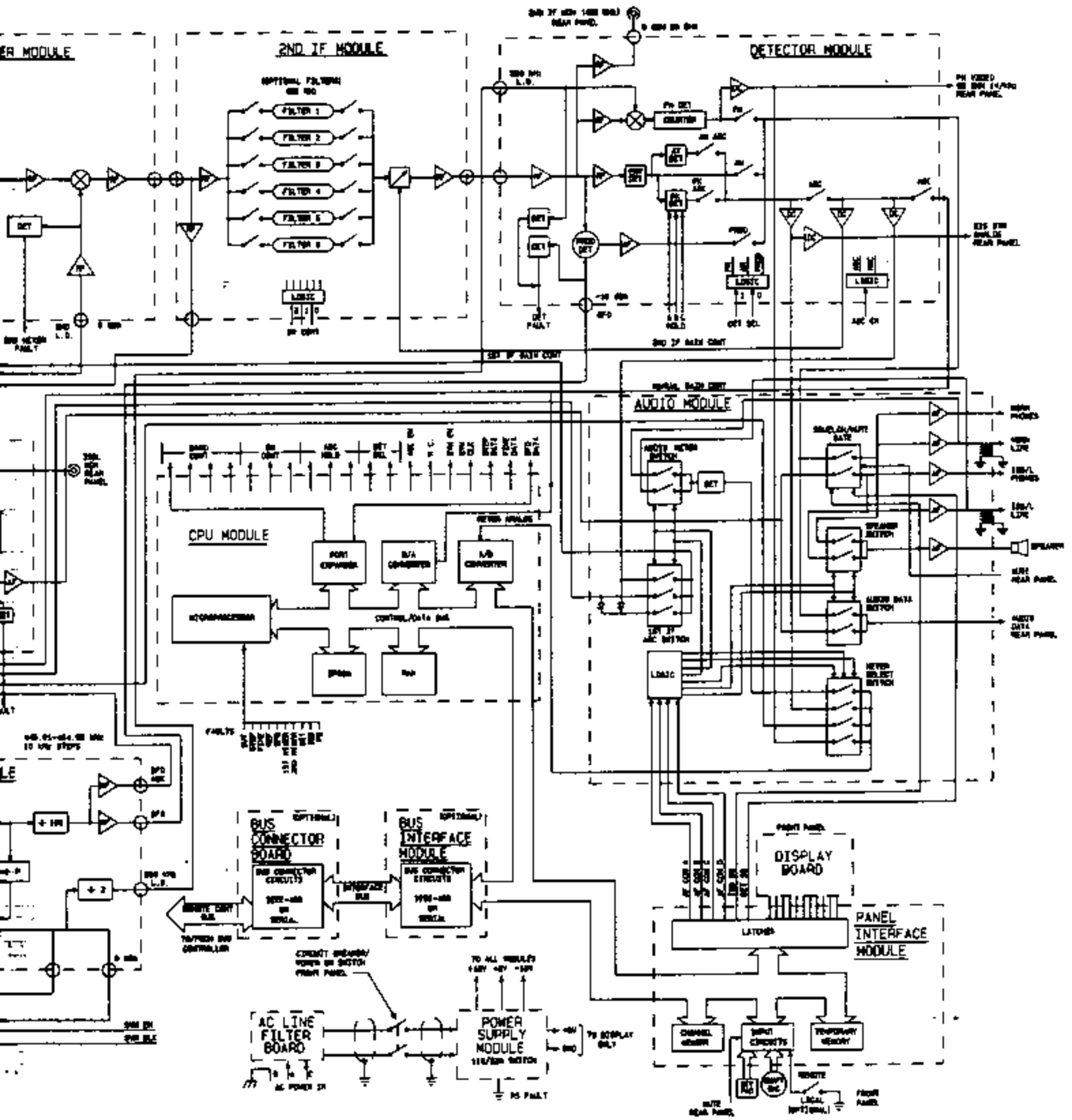

FO-2. Block Diagram (Typical).