

HAM KEYSER HK-5A DELUXE ELECTRONIC KEYSER

GENERAL

The HK-5A Keyer is a deluxe iambic keyer capable of keying grid block, cathode or solid state transmitters. The keyer has dot and dash memory and insertion circuits. The built in sidetone oscillator has front panel adjustable tone and volume controls. The unit can be powered from internal batteries or from an external 6 volt power supply. By using a straight key, the unit can be used for manual keying of the transmitter or as a code practice oscillator for learning the Morse code.

BATTERY INSTALLATION

Remove the top cover from the unit by removing two screws located on the rear lip of the cover. Slide the lid back to expose the battery holder. Install 4 C cells in the holder observing proper polarity. Reinstall top cover.

CONNECTING THE KEY

To fully utilize the features of the HK-5A, a squeeze-type keyer paddle such as the Ham-Key HK-1 should be used. The key should be connected with the 3-CKT 1/4 Phone Plug provided. The tip of the plug connects to the dot contact, the ring to the dash contact, and the sleeve to the common contact.

CONNECTION TO THE TRANSMITTER

A shielded cable should be fabricated to connect the HK-5A to the transmitter. An RCA Phono Plug should be installed on one end of the cable and a connector to mate with the transmitter key jack on the other end.

For transmitters employing grid block keying, connect the RCA Phono Connector to the grid jack on the back of the HK-5A. For cathode or solid state keyed transmitters, connect to the direct jack on the HK-5A.

The grid block circuit is capable of keying a maximum negative 300 volts to ground at 10 ma. of current. The direct output keys a maximum positive voltage of 300 volts to ground at 200 ma. maximum. Consult your transmitter operation manual for keying requirements.

OPERATION

The four position function switch on the front panel operates in the following manner:

OFF - removes both internal or external power from the keyer. Even though key-up current is nominal, battery life will be extended by turning the HK-5A off during periods of non-use.

ON - In the on position, the HK-5A is operational. The internal sidetone oscillator is not functional in this position. This position has been provided for those who desire to use a transmitter with a built in sidetone.

TONE - The tone position activates the built in sidetone circuit. The volume and pitch of the sidetone oscillator is adjustable from the front panel via the volume and tone controls.

SPEED CONTROL - The speed control adjusts the speed of the HK-5A over a range of approximately 8 - 50 WPM.

WEIGHT CONTROL - The weight control allows the lengthening of the dots and dashes for more distinctive keying. Advancing the weight control too far will result in constant keying.

VOLUME CONTROL - The volume control controls the volume of the internal sidetone oscillator.

tone control - The tone control controls the pitch of the internal oscillator.

EXTERNAL POWER JACK

The HK-5A may be powered by a 6 volt battery eliminator type unit. The battery eliminator should be equipped with a 2.5MM plug with the tip connected to the positive lead. Inserting the plug into the external power jack automatically disconnects the internal batteries.

HAND KEY JACK

The hand key jack accepts a standard 2CKT 1/4 inch phone plug (not provided). This jack allows manual operation of the transmitter while retaining the sidetone monitor feature built in to the HK-5A. The HK-5A may also be used as a code practice oscillator in this manner.

IAMBIC OR SQUEEZE OPERATION

Iambic or squeeze keying refers to the ability of the keyer to send alternate dots and dashes when both keyer paddles are depressed simultaneously. There are seven letters of the alphabet that can be "squeezed". They are C, F, K, L, Q, R and Y. Instead of keying each element of the letter separately, the letter can be sent with a single squeeze of the paddles. Some practice is necessary to become accomplished at squeeze keying but the result is smooth and almost effortless keying. As an example, the letter C can be squeeze keyed by squeezing both paddles simultaneously but leading the squeeze with the dash paddle.

The letter Q is squeezed by holding the dash paddle closed and inserting the dot at the appropriate time. The dash paddle should not be released until the entire character has been sent.

The squeeze technique is easier to learn at slower speeds so start slow and gradually increase your speed. Persistence is the key to success.

ERRATIC KEYING

There are two possible causes for erratic keying, dirty key contacts and RF interference from the station transmitter.

Dirty key contacts will usually cause letters to be missing dots or dashes. A periodic cleaning of the contacts with a good commercial contact cleaner will usually eliminate this problem.

The second problem, that of RF interference in the keyer may show up as steady or uncontrollable keying of the transmitter. If the HK-5A keys normally while the transmitter is turned off or is being operated at reduced power but is erratic with maximum RF output, the problem is caused by RF interference. One or more of the following suggestions should eliminate RF interference.

1. Connect a ground wire between the metal cabinet of the HK-5A and the transmitter. The station transmitter should always be connected to a good earth ground.
2. Use shielded cable to connect the HK-5A to the key.
3. Use shielded cable to connect the keying output of the HK-5A to the transmitter.
4. Position the HK-5A as far away as possible from sources of RF such as the transmitter, antenna tuners and any non-coaxial antenna leads.
5. Where a severe RF problem exists it may be necessary to install several ferrite beads on each of the leads leaving the HK-5A. To install the ferrite beads it will be necessary to unsolder the leads from the appropriate jacks in the HK-5A, thread several beads over each lead and resolder the lead to the jack. Ferrite beads are

available from a number of sources at minimal cost. Check the advertising section of a recent amateur radio periodical for current prices and availability.

90-DAY LIMITED WARRANTY

Ham Radio Center, Inc. warrants each new product manufactured to be free from defects in material and workmanship and agrees to remedy any defect or to furnish a new part in exchange for any part of any unit which under normal installation, use, and service, discloses such defect within the ninety-day term of this warranty, dated from the date of purchase by the original owner. This warranty applies only to the original purchaser.

This warranty does not extend to any of our products which have been subjected to mis-use, neglect, accident, incorrect wiring not our own, improper installation, or to use in violation of instructions furnished by us. Nor does it extend to units which have been repaired or altered outside our factory, not to accessories used therewith not of our own manufacture.

Upon receipt of equipment, the purchaser is responsible for checking the contents for damage. Any shipping damage should be referred to the carrier.

Ham Radio Center, Inc. reserves the right to make any changes deemed necessary or desirable without advance notice or incurring any obligation to make like changes in previously manufactured or sold.

~~The warranty does not cover transportation costs that may be incurred.~~ Ham Radio Center, Inc. sole liability is the remedy of any defect for the ninety-day period of this warranty. Ham Radio Center, Inc. is not responsible for personal injury or property damage resulting from improper or careless installation, or usage not intended by the manufacturer.

No person is authorized to assume for us any other liability in connection with the sale of our products.

You must furnish model number, date, place, and proof of purchase, such as a copy of the sales receipt to establish warranty. Your letter should include all pertinent details. No warranty card is furnished, you must supply the above information.

HAM RADIO CENTER, INC.
8340-42 Olive Blvd.
St. Louis, MO 63132

Model HK - 5A Electronic Keyer

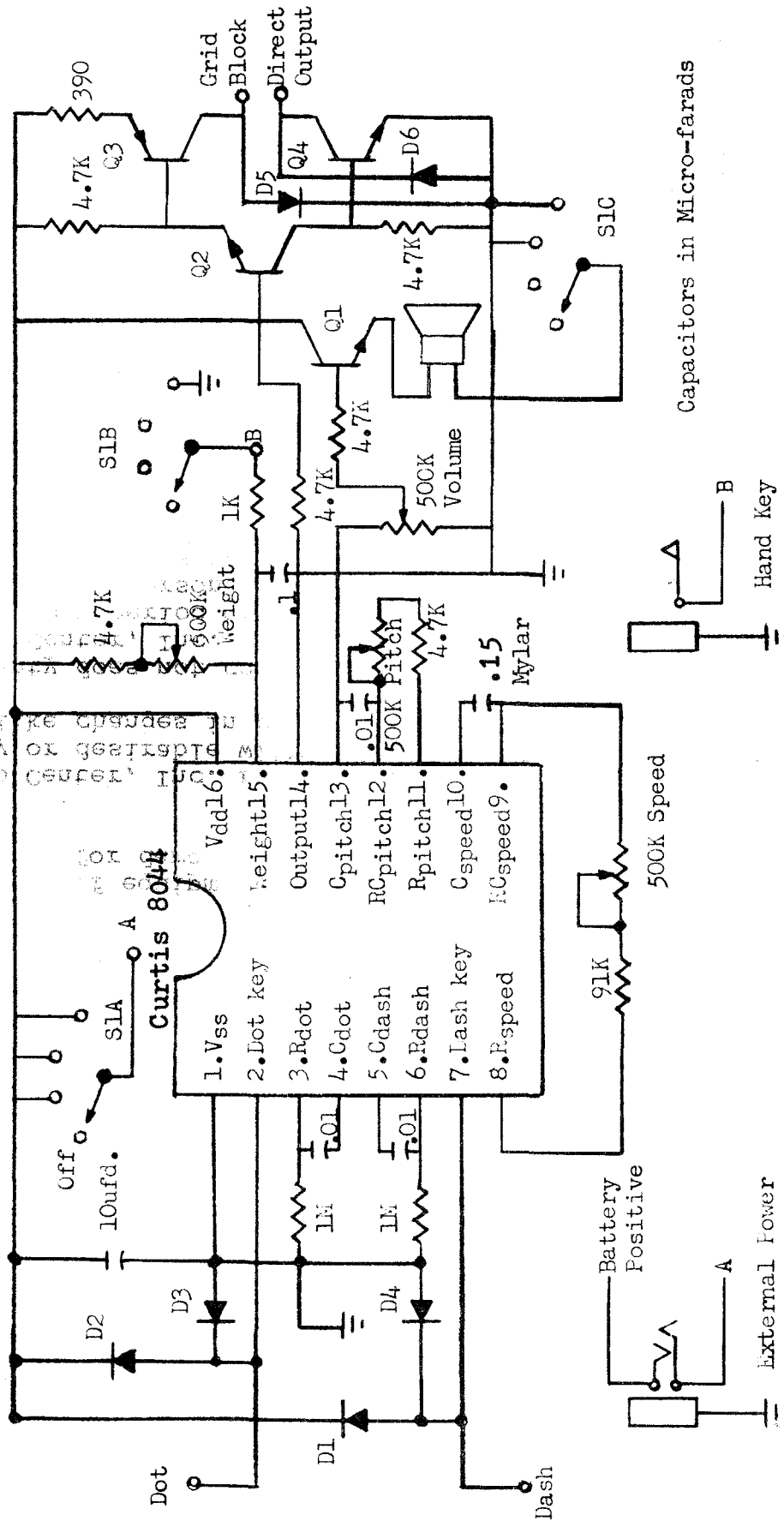

- D1-D4 1N34
- D5-D6 1N4006
- Q1 MFSAL3
- Q2 2N3904
- Q3 MFS92
- Q4 MFS42

Capacitors in Micro-farads

HAM RADIO CENTER INC.
8340-42 OLIVE BLVD.
ST. LOUIS, MO. 63132