

# NC-140

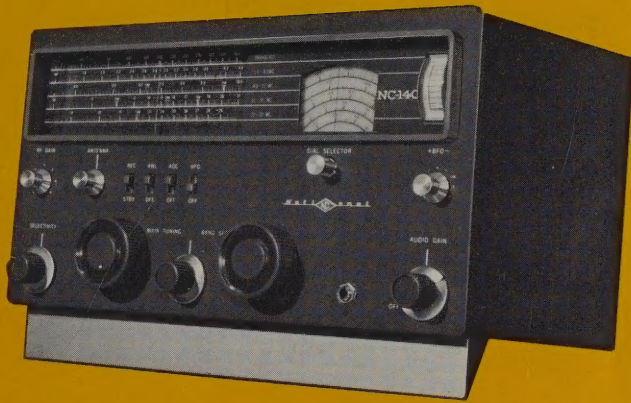

## National's New Double Conversion Receiver with Exclusive All-Band DIAL SELECTOR

Here's a top performer combining National's famous quality with features you won't find in any competitive receiver costing under \$200!

Here are the features of the NC-140 which are normally associated with much higher priced equipment:

- Double Conversion above 4 mc for rejection of annoying spurious signals and images.
- Vacuum Tube Q-Multiplier operates on AM and CW/SSB for continuously variable IF selectivity to reduce adjacent channel interference and heterodyne whistles.
- 6BZ6 RF Stage for top signal sensitivity and front-end selectivity.
- National's Exclusive Dial Selector for accurately calibrated foreign broadcast bandspread as well as amateur bandspread. If you listen to foreign broadcast, you can't afford to be without this feature!
- Five main tuning bands instead of the usual three or four provide superior calibration and stability on frequencies above 10 mc.

## SPECIFICATIONS

**MAIN TUNING RANGES:** 540-1600 KC, 1.6-4.0 MC, 4.0-10.0 MC, 10.0-20.0 MC, 20.0-30.0 MC. □ **INTERNATIONAL BROADCAST BANDSPREAD:** 13 meters: 21.5-22.1 MC, 16 meters: 16.4-18.0 MC, 19 meters: 14.6-15.4 MC, 25 meters: 11.7-12.0 MC, 31 meters: 8.6-10.0 MC, 49 meters: 5.9-6.3 MC. □ **AMATEUR BANDSPREAD:** 10 meters & CB: 26.6-30 MC, 15 meters: 21.0-21.5 MC, 20 meters: 13.8-14.5 MC, 40 meters: 6.9-7.5 MC, 80 meters: 3.5-4.0 MC. □ **CALIBRATION:** Bandspread dials calibrated every 20 KC or better below 10 meters; 10 meter amateur and CB calibrated every 50 KC. □ **DIAL SELECTOR:** allows foreign broadcast calibration equal to amateur band calibration. □ **CONVERSIONS AND INTERMEDIATE FREQUENCIES:** double conversion above 4 MC; 1st IF 2215 KC; 2nd IF 230 KC. □ **SENSITIVITY:** Better than 1.0 microvolt for 10 db S/N ratio. □ **SELECTIVITY:** Q-multiplier for AM and CW/SSB provides continuously variable selectivity from less than 500 cycles to 8 KC. □ **RECEPTION OF CW/SSB SIGNALS:** Calibrated USB/LSB BFO control, Q-Multiplier, stable 230 KC BFO. □ **SIGNAL STRENGTH METER:** Edge-reading; calibrated in S-units from S-1 to S-9 and 10 db to 60 db above S-9. □ **AUDIO POWER OUTPUT:** 3.0 watts; 3.2 ohms for loudspeaker, separate front panel headphone jack. □ **ANTENNA INPUT:** 50 ohms; unbalanced. □ **CONTROL CIRCUITS:** Front panel standby-receive switch for control of transmitter; external control of receiver if desired. □ **FRONT PANEL CONTROLS:** Main tuning, bandspread tuning, audio gain, RF gain, antenna trim, rec-standby, ANL On-Off, AGC On-Off, BFO On-Off, Dial Selector, BFO-USB/LSB, selectivity, bandswitch, earphone jack. □ **NOISE LIMITER:** High performance series gate with front panel control. □ **POWER REQUIREMENTS:** 105-125 volts AC, 50-60 cycles, 75 watts. □ **DIMENSIONS:** 8 $\frac{3}{4}$ " H, 15 $\frac{3}{4}$ " W, 9" deep. □ **SHIPPING WT.:** 28 pounds. □ **ACCESSORIES:** NT-3B matching speaker, XCU-27 .1 MC crystal calibrator. □ **TUBE FUNCTIONS:** 6BZ6 (V1), RF Stage; 12BE6 (V2), 1st Mixer; 12BE6 (V2), HF Oscillator; 12BE6 (V3), 2nd Conversion Mixer; 12BE6 (V3), 2nd Oscillator; 12BA6 (V4), 230 KC IF Amplifier; 12BA6 (V4), Q Multiplier; 12AV6 (V6A), Detector; 12AV6 (V6B), Audio Amplifier; 6 BN8 (V7A), ANL; 6BN8 (V7B), BFO; 6CW5 (V8), Audio Output; 5Y3GT (V9), Rectifier.

# NC-190

Also ideal as a general coverage receiver for the advanced ham-band-only station or as a tunable IF for use with VHF converters, the NC-190 provides double conversion, true variable IF selectivity from 0.6 KC to 5 KC with the Ferrite Filter, and sensitivity better than 1.0 uv for 10 db S/N. A separate product detector, SSB AGC and calibrated USB/LSB BFO control result in excellent SSB performance, while the use of a 60:1 planetary tuning mechanism in the bandspread dial offers ease of tuning superior to any other two-dial general coverage receiver at any price, and equivalent to the better ham-band-only equipments. Frequency coverage from 540 KC to 30 MC in five main tuning bands rather than the usual three or four, provides superior stability and high frequency calibration — bandspread scales are provided for 80, 40, 20, 15, and 10 meters as well as the five most popular foreign broadcast bands. Coaxial antenna input, voltage-regulated oscillators, SSB/CW IF noise limiting as well as AM limiting, an edge-reading S-meter operative on all reception modes combine to offer more receiver for the money than ever believed possible.

## SPECIFICATIONS

**AMATEUR BANDSPREAD:** 10 meters: (26.6-30.0 MC) 15 Meters: (21.0-21.5 MC), 20 Meters: (13.8-14.5 MC), 40 Meters: (6.9-7.5 MC), 80 Meters: (3.5-4.0 MC). □ **INTERNATIONAL BROADCAST BANDSPREAD:** 13 Meter Band: (21.5-22.1 MC), 16 Meter Band: (16.4-18.0 MC), 19 Meter Band: (14.6-15.4 MC), 25 Meter Band: (11.7-12.0 MC), 31 Meter Band: (8.6-10.0 MC), 49 Meter Band: (5.9-6.3 MC). □ **MAIN TUNING RANGES:** 540-1600 KC, 4.0-10.0 MC, 10.0-20.0 MC, 20.0-30.0 MC. □ **IMAGE REJECTION:** 6BZ6 RF Stage and double conversion above 4 MC (1st IF-2215 KC, 2nd IF-230 KC). □ **AUDIO AMPLIFIER:** 3.2 ohm output. More than 1 watt at 10% distortion. □ **FRONT PANEL HEADPHONE JACK:** □ **STABILITY:** The use of a 1/8" steel panel, 1/16" steel chassis, ceramic coil forms and rugged oscillator components assure excellent mechanical stability. All oscillators are voltage regulated, which minimizes frequency changes as a result of voltage variations. □ **CALIBRATOR:** Accessory XCU-27 calibrator provides .1 MC markers throughout tuning range. □ **AUTOMATIC GAIN CONTROL (AGC):** AGC operation is available for both AM and SSB/CW signals, allowing effortless tuning of any type of signal under widely varying signal input conditions. □ **"S" METER:** Edge-reading, operates on all reception modes. □ **NOISE LIMITERS:** Automatic series gate for AM IF limiting for SSB/CW. □ **PRODUCT DETECTOR:** triode type for SSB/CW with separate diode detector for AM. □ **TUNING RATIO:** 60:1 bandspread ratio with built-in National Velvet Vernier. □ **SELECTIVITY:** 230 KC. Ferrite Filter provides 600 cycle CW, 3 KC SSB, and 5 KC AM bandwidths at 6 db points. □ **TUBE COMPLEMENT:** 6BZ6 RF amplifier, 12BE6 HF Converter; 12BE6 2nd Converter; 12BA6 IF Amplifier; 12BA6 IF Amplifier; 12AX7A Product Det-BFO; 6T8 AM Det, ANL, AGC, Audio Amp., 6CW5 Audio Output; 5Y3GT Pwr Rect., 0B2 Voltage Reg. □ **FRONT PANEL CONTROLS:** Main tuning, Bandspread, Dial Selector, RF gain, Antenna trim, REC-STBY, ANL, AGC, BFO, Calibrator, BFO adjust, Selectivity, Bandswitch, Audio gain, Earphone jack. □ **POWER REQUIREMENTS:** 105-125 volts AC, 50-60 cycles, 75 watts. □ **DIMENSIONS:** 8 3/4" high, 15 3/4" wide, 9" deep. □ **SHIPPING WEIGHT:** 28 pounds. □ **ACCESSORIES:** XCU-109 Crystal calibrator; NTS-3B matching speaker. **EXPORT MODEL NC-190X** (115/220 V.A.C. 50/60 cycle input).

**NATIONAL RADIO COMPANY, INC.**   
37 WASHINGTON ST., MELROSE, MASS. 02176



Combining exceptional SSB, AM and CW amateur band performance with calibrated foreign broadcast bandspread, the National NC-190 sets a new standard of value for amateur receivers. National has incorporated every desirable feature necessary to conquer crowded amateur band conditions, plus National's patented Dial Selector to provide bandspread for shortwave as well as amateur broadcast bands.

# INSTRUCTION MANUAL



# NC-140

National Radio Company, Inc.

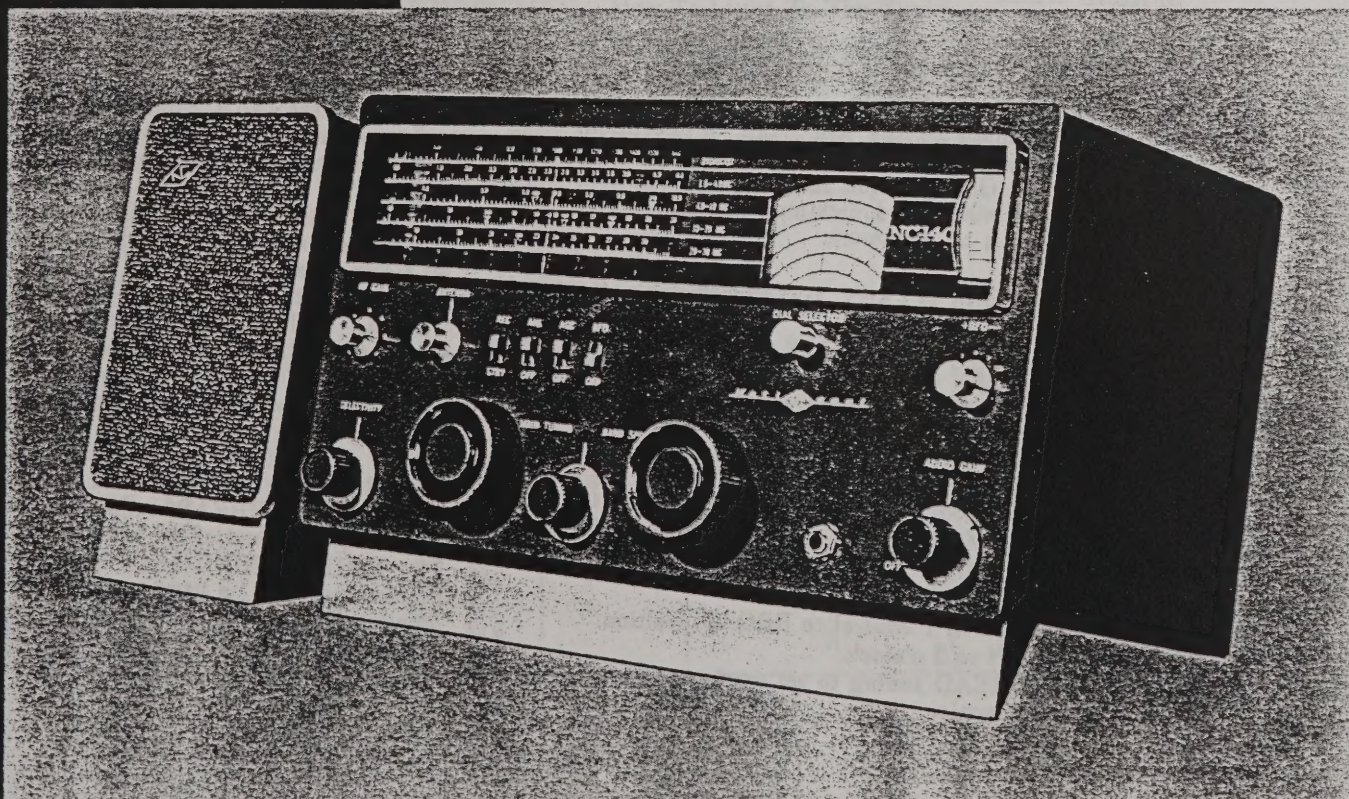

## READ CAREFULLY BEFORE TURNING ON YOUR NEW NC-140

The following instructions are designed to allow you to immediately set up your new NC-140 for proper operation using AM, SSB or CW receiving techniques. They are ONLY intended to provide a quick reference for proper set-up procedure, and we strongly recommend that you study the detailed instructions of this manual as soon as possible.

### CW OPERATION

1. Set BANDSWITCH to desired band.
2. Set DIAL SELECTOR for desired calibration.
3. Set STBY-REC switch to REC.
4. The ANL switch is inoperative in this mode of operation and may be left in any setting.
5. The AGC switch is also inoperative in this mode of operation, and may be left in any setting.
6. Set BFO switch ON.
7. Turn SELECTIVITY control clockwise until receiver "howls". Set control just below this point.
8. Set BFO control to approximately 1 o'clock. BFO control may be moved from this setting as desired to obtain a comfortable beat note.
9. Turn AF GAIN control clockwise to apply power to the receiver. Continue to turn control until it is almost fully clockwise.
10. Turn RF GAIN control clockwise. Volume may then be adjusted with this control for a comfortable listening level.
11. Adjust ANTENNA control for maximum background noise in the absence of a signal.
12. Rotate BANDSPREAD control to set mark at the high frequency end of the scale.
13. The MAIN TUNING control is now properly calibrated and may be used to tune the receiver. The detailed instructions in the manual should be studied for proper setting of the MAIN TUNING control when it is desired to use the calibrated BANDSPREAD scales.

### USE OF THE S METER

The S meter of the NC-140 receiver will indicate relative signal strength in the AM mode of reception. The AGC switch must be in the ON position and the BFO switch in the OFF position for S meter operation. For proper signal strength indication, the RF GAIN control should be set at maximum.

### BROADCAST BAND RECEPTION

For broadcast reception the MAIN TUNING control and the AUDIO GAIN control correspond to the TUNING and VOLUME controls of any broadcast receiver and may be so used providing the rest of the receiver controls are adjusted as indicated below:

1. Set BANDSWITCH to .54-1.6 Mc.
2. Set STBY-REC switch to REC.
3. Set ANL switch OFF.
4. Set AGC switch ON.
5. Set BFO switch OFF.
6. Turn SELECTIVITY control to BROAD position.
7. Turn RF GAIN to 3 o'clock.
8. Set BANDSPREAD tuning to set mark at high frequency end of scale.

### AM OPERATION

1. Set BANDSWITCH to desired band.
2. Set DIAL SELECTOR for desired calibration.
3. Set STBY-REC switch to REC.
4. Set ANL switch ON or OFF as desired.
5. The AGC switch is also inoperative in this mode of operation, and may be left in any setting.
6. Set BFO switch OFF.
7. Turn SELECTIVITY control to BROAD position.
8. Turn RF GAIN control fully-clockwise.
9. Turn AF GAIN control clockwise to apply power to the receiver. Volume may then be adjusted with this control for a comfortable listening level.
10. Adjust ANTENNA control for maximum background noise in the absence of a signal.
11. Rotate BANDSPREAD control to set mark at the high frequency end of the scale.
12. The MAIN TUNING control is now properly calibrated and may be used to tune the receiver. The detailed instructions in the manual should be studied for proper setting of the MAIN TUNING control when it is desired to use the calibrated BANDSPREAD scales.

### SSB OPERATION

1. Set BANDSWITCH to desired band.
2. Set DIAL SELECTOR for desired calibration.
3. Set STBY-REC switch to REC.
4. The ANL switch is inoperative in this mode of operation and may be left in any setting.
5. Set AGC switch OFF.
6. Set BFO switch ON.
7. Turn SELECTIVITY control to BROAD. This control may be turned clockwise to just below the point where the receiver "howls" if more selectivity is desired.
8. Set BFO control to the USB or LSB mark to select the desired sideband (usually LSB on the 80 and 40 meter amateur bands and USB on the 20, 15 and 10 meter amateur bands).
9. Turn AF GAIN control clockwise to apply power to the receiver. Continue to turn control to 3 o'clock.
10. Turn RF GAIN control clockwise. Volume may then be adjusted with this control for a comfortable listening level.
11. Adjust ANTENNA control for maximum background noise in the absence of a signal.
12. Rotate BANDSPREAD control to set mark at the high frequency end of the scale.
13. The MAIN TUNING control is now properly calibrated and may be used to tune the receiver. The detailed instructions in the manual should be studied for proper setting of the MAIN TUNING control when it is desired to use the calibrated BANDSPREAD scales.

# DESCRIPTION AND OPERATION

A world of adventure lies at your fingertips as you tune the NC-140 receiver. The chimes of Big Ben, the call of a Bell Bird in New Zealand. The news in English from foreign nations, the cryptic messages of police, aircraft, and ships at sea, the gossip and friendly talk of amateur radio operators around the world can all be heard in the comfort of your armchair. This world of short wave listening is available to you through proper use of the National NC-140.

Unlike regular broadcast stations that you hear any time of the day, short wave transmissions are subject to variation from day to day, time of day, season of the year and even such things as sunspot activity. These variations cause changes in the nature of the upper atmosphere of the earth, which acts like a giant mirror reflecting short wave radio signals. When conditions are right the radio signal may travel entirely around the world bouncing back and forth from the upper part of the atmosphere to the ground and back again. If the receiving antenna happens to be at one of the points of reflection then the signal may be heard as though it were located just next door.

Most of these variations follow definite patterns and as a result the short wave broadcasters schedule their times and frequencies of transmissions to take best advantage of transmitting conditions. Likewise the listener can take advantage of this information to achieve greatest satisfaction in pursuit of the hobby of short wave listening. In other words it is important to know where to look and when to listen.

A radio wave (like a wave in the ocean) goes through a repeated up and down motion. If this electrical signal varies up and down 100 times each second we say that its frequency is 100 cycles per sec. In the short wave spectrum tuned by the NC-140 this frequency may actually be measured as many millions of cycles, and it is therefore easier to divide the frequency by one million and call the result "megacycles". The dial of the NC-140 receiver is calibrated in "megacycles", an expression of the frequency of the radio signal to which we are tuned. Thus when a station is listed as transmitting on a frequency of 8.61 megacycles (8,610,000 cycles) it may be tuned by setting the NC-140 dials to this same frequency. A chart showing approximate frequency limits for various types of transmission covered by the NC-140 tuning range is given below. Many of these transmissions are in

code or teletype, others are in voice, making up the myriad tones and voices of short wave radio.

Many short wave listeners find that their main interest is tuning the many foreign broadcast stations. It is always helpful to keep a log of the station heard and the date and time, as well as the frequency of reception. Most of these foreign broadcast stations welcome reports from listeners and mail out interesting and colorful cards confirming the fact that the station was heard and providing information about the country and the station. The collection of these cards is in itself an interesting hobby. Generally speaking, the foreign shortwave broadcast stations are found in groups or bands of frequency. The NC-140 handsread dial is calibrated for six of these foreign broadcast bands as well as for five amateur bands. The shortwave broadcast listener will find the following chart useful as a guide to listening locations and times for best broadcast reception.

band	frequency	Morning	Afternoon	Evening
49 meters	5.9-6.3 mc.	good	poor	good
31 meters	8.6-10.0 mc.	poor	fair	good
25 meters	11.7-12.0 mc.	poor	fair	good
19 meters	14.6-15.4 mc.	fair	good	poor
16 meters	16.4-18.0 mc.	good	fair	poor
13 meters	21.5-22.0 mc.	good	fair	poor

These few words hardly scratch the surface of the hobby of short wave listening. For best results from the NC-140 receiver the following pages on operation of the receiver should be carefully studied. In addition the following publications should prove useful in furthering enjoyment of the hobby.

Official Log—National Association of Armchair Adventurers—National Radio Company, Melrose, Mass.

The Radio Amateur's Handbook and other publications  
American Radio Relay League, West Hartford, Conn.

How To Listen To The World

World Radio TV Handbook  
Giffler Associates, Box 239, New York 17, N. Y.

World Radio Handbook — World Radio Publications,  
47 Mounthaven Dr., Livingston, N. J.

In addition many periodicals and the Government printing office publish information on a regular basis.

## ALL FREQUENCIES IN MEGACYCLES

Amateur	International Broadcast	Frequency Standard (WWV)	Citizens Band	Marine	Aeronautical	Police	Public Safety (Forestry Conserv'n, State Guard, Special Emergency, Highway Maint.)	Industrial
1.8 - 2.0	2.3 - 2.5	2.5 MC	26.9 - 27.3 MC	2.0 - 2.8	2.6 - 3.5	1.6 - 1.8	2.2 - 2.3	1.6 - 1.8
3.5 - 4.0	3.2 - 3.4	5.0 MC		4.0 - 4.5	4.5 - 6.0	2.3 - 2.5	2.7 - 2.8	2.2 - 2.5
7.0 - 7.3	3.9 - 4.0	10.0 MC		6.2 - 6.6	6.5 - 7.0	2.8 - 2.9	3.2 - 3.3	4.6 - 4.7
14 - 14.4	4.7 - 5.1	15.0 MC	Common Carrier (Telephone, Telegraph, Press)	8.2 - 8.9	8.8 - 9.0	5.1 - 5.2	27.2 - 27.3	25.0 - 25.3
21 - 21.5	5.9 - 6.2	20.0 MC	4.4 - 5.4	12.3 - 13.2	10.0 - 11.5	7.4 - 8.0		27.2 - 27.5
28 - 29.7	7.1 - 7.3	25.0 MC	6.7 - 8.0	16.4 - 17.4	13.2 - 14.0		Broadcast Auxiliary (Remote Pick-up)	29.7 - 30.0
	9.5 - 9.8		9.0 - 9.5	22.0 - 22.8	15.8 - 18.0		1.6 - 1.7	
	11.7 - 12.0		9.7 - 11.7				25.8 - 26.5	
	15.1 - 15.5		13.3 - 21					
	17.7 - 17.9		22.6 - 24.6					
	21.4 - 21.8		29.8 - 30.0					
	25.6 - 26.1							

The National NC-140 receiver is designed to match an unbalanced 50 ohm antenna transmission line. Individual antenna coils are used on each band. Impedance match is obtained by use of small primary coupling windings on the antenna coils.

## THE ANTENNA

The NC-140 incorporates a two terminal antenna strip suitably marked A (antenna) and G (ground) to connect the antenna to the receiver. The simplest antenna is a single long wire antenna illustrated in the figure below. When an antenna of this type is used, a suitable ground connection is recommended for best results. Generally speaking, an antenna between 15 feet and 40 feet long should provide ample signal pick-up for most of the bands in use. When the receiver is to be used predominantly on any one band, better results can be obtained with one of the many types of tuned antennas. The subject of antennas and the matching of antennas to receivers is in itself a major study. The owner of the NC-140 should consult many of the excellent references published by the American Radio Relay League and other organizations. In all cases where an external exposed antenna is employed, suitable consideration should be given to lightning protection for the sake of insuring safety to the operator and to the equipment.

The proper antenna coil is selected by means of the bandswitch which switches the primary and secondary windings of the desired coil into the receiver circuit. On the broadcast band, the bandswitch connects the secondary of the antenna coil directly to the mixer grid bypassing the RF stage.

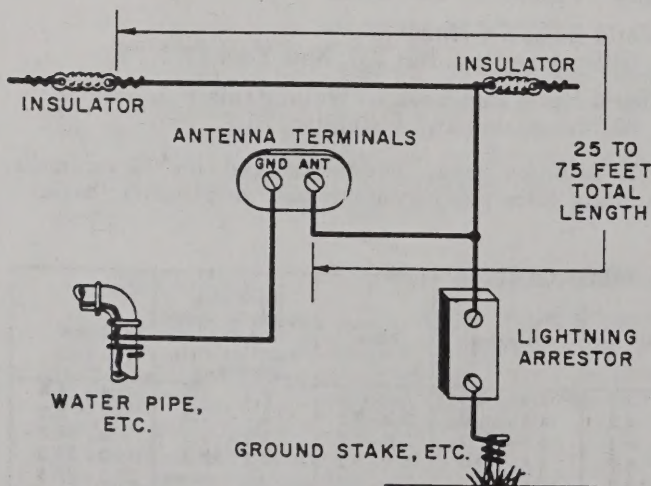

## SINGLE WIRE ANTENNA

## BANDSWITCH

The bandswitch of the NC-140 is labeled in megacycles. The switch is simply placed in the desired band position as indicated by the markings .54-1.6, 1.6-4.0-10, 10-20 and 20-30. When the bandswitch has been set for the band desired, the corresponding general coverage dial scale is used to indicate the frequency receiver tuning.

The secondary of the antenna coil is used as a tuning circuit to achieve selectivity in the antenna stage of the receiver. This coil is tuned by means of the main tuning capacitor, the bandspread capacitor and the antenna trimmer.

## ANTENNA TRIMMER

The antenna trimmer control is used to make a fine adjustment of the tuned circuit to insure maximum gain on the frequency region in use. Adjustment is necessary because the presence of various types of antennas will have some detuning effect on the antenna stage. The use of the antenna trimmer allows compensation of the receiver to match any type of antenna which may be connected to it. It is normally necessary to set the antenna trimmer only once for a frequency region in use. This is best accomplished by tuning the receiver away from any signal and adjusting the antenna trimmer for maximum background noise in the speaker or earphones.

The main tuning and bandspread capacitors determine the frequency to which the antenna, mixer and oscillator coils are tuned. The signal appearing across the antenna coil is coupled to the RF amplifier.

## MAIN TUNING

The main tuning knob adjusts the setting of the main tuning capacitor. The pointer of the slide rule main tuning dial is coupled to the tuning capacitor to indicate frequency of operation. Proper frequency calibration of the main tuning dial depends on the setting of the bandspread dial. A triangular shaped set mark appears at the high frequency end of the bandspread scales in use. The bandspread dial should be set so that this triangular set mark appears directly under the bandspread index line. When set in this manner, the general coverage dial may be freely used to tune the receiver and the frequency of operation will be that determined by the dial scale corresponding to the setting of the bandswitch.

The bandspread capacitor is connected in parallel with the main tuning capacitor and acts as a vernier tuning control.

## BANDSPREAD TUNING

The crowded frequency spectrum of the shortwave bands makes tuning of individual signals a difficult task unless some means of fine tuning (bandspread tuning) is provided. The bandspread knob of the NC-140 receiver provides this feature.

As the bandspread control is tuned counter-clockwise, the bandspread dial will rotate clockwise from the triangular set mark and the frequency to which the receiver is tuned will be reduced just as though the main tuning control were tuned to a lower frequency. Rotation of the bandspread control will accomplish this frequency change at a much slower rate than can be accomplished through use of the main tuning control, thus making it possible to tune the crowded shortwave bands with ease. The bandspread dial is calibrated in megacycles over regions of principal listener interest. Proper calibration of the bandspread dial ranges requires that the main tuning pointer be located at the triangular set mark corresponding to the bandspread range in use. If it is desired to use the bandspread dial as a fine tuning device, for frequencies at which it is not calibrated, the main tuning dial should be set just above the region of interest. The bandspread dial will now function as a fine tuning control in this frequency region even though it does not carry corresponding calibration marks.

The bandspread dial is attached to the bandspread capacitor by means of the exclusive NATIONAL DIAL SELECTOR mechanism which permits mechanical change of the dial ranges appearing in the bandspread dial window.

## DIAL SELECTOR

The exclusive NATIONAL DIAL SELECTOR knob appears immediately below the bandspread dial window. It is operated by pulling the selector knob forward and rotating the knob one-half turn until the detent engages at which point the dial selector knob will snap back in towards the panel. As the dial selector is rotated, two different groups of bandspread dials will appear in the bandspread window. One of these sets of dials is calibrated in red and provides accurate bandspread tuning calibration of the 80, 40, 20, 15, and 10 meter amateur bands. The other set of dials is calibrated in midnight blue and provides accurate bandspread tuning calibration of the 49, 31, 25, 19, 16 and 13 meter foreign broadcast bands.

As mentioned in the previous section, proper calibration of any of the bandspread tuning ranges requires that the main tuning dial be set to the proper triangular set mark. The set marks corresponding to the red amateur scales are calibrated in red on the main tuning dial and the set marks corresponding to the midnight blue foreign broadcast scales are calibrated in white on the main tuning dial. The set marks are identified for each particular bandspread scale by the numbers appearing directly above them while the particular bandspread scale is identified by the same number appearing directly to the right of the bandspread index line when the triangular bandspread set mark is set at the index line. For example, the red set mark carrying the designation 80M corresponds to the 80 meter amateur band

calibrated in red on the bandspread dial. When the main tuning pointer is set to this red mark and the bandswitch is set for the corresponding band, the bandspread dial will directly read frequencies between 3.5 and 4 megacycles, the frequency range of the 80 meter amateur band.

The signal from the RF stage is coupled to a primary winding on the mixer coil. The secondary of the mixer coil is tuned by another section of the main and bandspread tuning capacitors. The bandswitch again selects the proper coil corresponding to the band in use. The signal on the secondary of the mixer coil is coupled to the high frequency converter. The high frequency oscillator is a grounded plate Hartley oscillator using the cathode, grid and screen of the high frequency converter. A third section of the main and bandspread tuning capacitors tunes the oscillator with the bandswitch again selecting the coil for the band in use.

The high frequency oscillator operates 230 kilocycles above the signal on the two lowest frequency bands and operates 2,215 kilocycles above the signal on the three highest frequency bands. The output of the converter is fed to two transformers, one at each of the above frequencies. Signals appearing across the secondary of these transformers are coupled to the second converter. A grounded plate Hartley oscillator is constructed between the cathode, grid and screen of this stage operating at a frequency of 1985 kilocycles. On the two lowest bands the bandswitch disables this oscillator and the second converter operates as a straight amplifier at 230 kilocycles. On the three highest bands, the oscillator is operating and converts the 2215 kilocycle signal to 230 kilocycles. The signal from the second converter is coupled to the combination IF amplifier — Q multiplier which provides excellent selectivity in the signal path and control of overall bandwidth by means of the selectivity control.

## SELECTIVITY

The selectivity control of the NC-140 combination IF amplifier — Q multiplier provides continuously variable receiver selectivity. The degree of selectivity needed depends largely on the mode of reception and existing signal conditions. The BROAD position, which provides an IF bandwidth of 8 Kc., would normally correspond to the highest receiver fidelity. However, under conditions of extreme signal interference, it is often desirable to reduce the bandwidth of the receiver and sacrifice fidelity in favor of less interference. This may be done by rotating the SELECTIVITY control clockwise from the BROAD position. This activates the Q multiplier portion of the 1st IF amplifier. Further clockwise rotation will reduce the NC-140 bandwidth from 5 Kc. to less than 150 cycles. The narrowest bandwidth is obtained just below the point where oscillation, or "howling" occurs, which is at about 7 or 8 o'clock on the SELECTIVITY control.

When CW reception is desired, a very sharp setting of the selectivity control is desirable. For Single Sideband operation, a setting which produces a slightly wider bandwidth is very effective, and produces remarkable unwanted sideband rejection. A setting which produces a still wider bandwidth is normally desirable for AM reception.

*It should be noted that for AM reception, the beat frequency oscillator should be turned off. For single sideband or CW operation, the beat frequency oscillator should be turned on. The beat frequency oscillator is discussed in later sections of this book.*

The signal from the Q multiplier — 1st IF amplifier is coupled to the double tuned transformer between the first and second IF amplifier and appears on the second IF amplifier grid.

### RF GAIN

*The sensitivity of the receiver is adjusted by means of the RF gain control which controls the cathode bias on the RF and 2nd mixer stages. When the control is rotated to its maximum counter-clockwise position, the sensitivity of the receiver will be reduced to the point where no signal can be received. Rotating the control in the clockwise direction will increase sensitivity until maximum is reached at the full clockwise position. The RF gain control may be freely used as a means of sensitivity adjustment as the receiver is tuned from signal to signal or it may be set to maximum sensitivity level and allowed to remain in this position. Adjustment of the RF gain control will have some effect on the "S" meter reading. FOR PROPER INDICATION OF THE "S" METER it is necessary that the RF gain control be advanced to maximum.*

The signal from the last IF stage is again coupled through a double tuned transformer which feeds the diode AM detector. The average signal level appearing at this detector is, at all times, proportional to signal input and is used as AGC voltage which is applied to the RF and second mixer stage and, in addition, to the first mixer on the broadcast band only. A positive delay voltage is fed to the AGC bus to provide maximum signal-to-noise-ratio receiving weak signals.

### AGC SWITCH

*The AGC switch is used to turn the automatic gain control on or off. The automatic gain control is intended for use with AM operation, and is inoperative in other modes of reception. When the AGC switch is turned on, the received signal level is automatically adjusted for a predetermined output and the "S" meter will indicate relative signal level. When the AGC switch is turned off, the "S" meter is disabled and the output of the receiver will vary in accordance with the incoming signal strength.*

For single sideband or CW reception, the signal is coupled directly from the plate of the last IF amplifier to the diode AM detector. A grounded cathode Hartley oscillator using the triode section of the Noise Limiter BFO tube is used for BFO injection.

### BFO SWITCH — BFO CONTROL

*The BFO switch is used to turn the beat frequency oscillator on or off. When the BFO switch is turned off, the beat frequency oscillator is disabled and the BFO control will not function. When the BFO switch is turned on, the S meter is disabled and the AGC circuit is turned off. The BFO control is used to adjust the frequency of the beat frequency oscillator which varies the pitch of the generated audio tone. When receiving single sideband signals, the beat frequency oscillator control should be set in the region marked USB or LSB depending on the desired sideband. It is not normally necessary to detune the beat oscillator from this setting. When receiving CW signals, a mid-position setting of the beat oscillator corresponds to a condition where maximum IF selectivity occurs at zero beat with the incoming signal and no audio tone will be observed at the point of maximum signal reception. It is therefore necessary to detune the beat oscillator control in either direction to provide a suitable audio tone which is comfortable to the operator and to obtain maximum amplitude of the desired beat note. During CW reception, it is often convenient to adjust the beat oscillator to phase an undesired signal to zero beat, thus eliminating it as an audible interfering signal.*

The signal from the AM detector is coupled to a series gate automatic noise limiter which is designed to reject all signals exceeding the average modulation level.

### ANL SWITCH

*The ANL switch turns the automatic noise limiter on or off. The automatic noise limiter will function only when the BFO control is set in off position for AM reception. In normal operation, the noise limiter may be used at will depending on incoming noise level and operating convenience. This Automatic Noise Limiter is intended for use with impulse noise, such as ignition interference or static. It will not appreciably improve performance on continuous, high energy noise such as "hash", thermal or cosmic noise.*

The signal from the AM detector and noise limiter is coupled to the first audio amplifier through the audio frequency gain control.

### AUDIO GAIN

*The audio gain control is used to adjust the speaker or earphone level to comfortable listening volume. It is important not to confuse the function of the audio gain control with the function of the RF gain control which controls the overall receiver sensitivity. Normally, with the RF gain control advanced to provide proper "S" meter reading, all additional variation of listening level is accomplished with the audio gain control. In the event of operation with AGC "OFF", the RF gain control is usually used as the master sensitivity control and the audio gain control is left set in a predetermined position. Proper balance between the two controls under this condition is normally a matter of individual operator preference and operating habits.*

The amplified audio signal is coupled to the audio output stage and, in turn, through the audio transformer to the speaker terminals. The secondary winding of the audio transformer is designed to match a 3.2 ohm speaker such as the matching NTS-3 table speaker. The output signal is also coupled to a shorting type phone jack on the front panel.

### PHONE JACK

The head phone jack is located on the front panel and will accept any normal 2 circuit phone plug. There is no DC voltage associated with the head phone circuit. Because of the low impedance of the audio transformer secondary almost any type of head phone may be used with completely satisfactory results. Insertion of a standard phone plug will break the loudspeaker circuit and silence the speaker.

The "S" meter is connected in a bridge circuit between the plate decoupling resistors of the RF amplifier and second IF stages. AGC voltage is applied to the first of these stages so that the change in plate current will cause the "S" meter to read relative signal strength.

### "S" METER

Normal adjustment of the "S" meter is readily accomplished by disconnecting the antenna and increasing the RF gain control to maximum sensitivity which corresponds to its extreme clockwise setting. The receiver should be tuned so that only background noise is heard and the antenna trimmer peaked. The "S" meter zero adjust control should then be adjusted to achieve a reading of approximately S1 on the incoming noise level. This will assure proper "S" meter reading. When properly adjusted, an "S" meter reading of S9 will correspond to approximately 50 microvolts of signal at the antenna terminals.

The power supply of the NC-190 receiver is a conventional transformer operated circuit using a full wave rectifier with suitable filter and shunt feed to the voltage regulator tube. The regulated voltage is used for all receiver oscillators to assure maximum stability. A standby-receive switch is used to remove power from plate and screen of most tubes for standby operation.

### STBY-REC SWITCH

The Standby-Receive switch is a two position toggle switch which may be set to standby to mute the receiver or placed in the receive position for normal operation.

If the Standby-Receive switch is left in the Standby position, the receiver can be operated by shorting ter-

minals 3 and 4 of the calibrator socket, thus providing for external control of the receiver.

A crystal calibrator socket is provided on the rear apron to accept the accessory XCU-109 crystal calibrator. A toggle switch mounted on the XCU-109 calibrator is used to turn the accessory calibrator on and off.

### CRYSTAL CALIBRATOR

When the accessory XCU-109 calibrator is plugged into the receiver and the calibrator switch is turned on a signal will appear at every 1 megacycle point on the main tuning dial. As discussed in the sections on tuning, the main tuning dial will read correctly only when the bandspread dial is set to proper position. The 1 megacycle signals may now be used to check the accuracy of the main tuning dial. In the event that the 1 megacycle signal does not appear exactly at a 1 megacycle point on the dial, the bandspread dial may be slightly rotated to move the 1 megacycle signal to exact position on the main tuning dial. In like manner, the main tuning dial may be moved slightly from a set point to assure accurate calibration of the bandspread dial. It is sometimes convenient to turn on the beat frequency oscillator in order to add tone to the calibrator signal so that it may be more readily located.

A separate bottom cover and cabinet top are employed for ease in servicing and the National Radio Company patented Flip-Foot has been added for operator convenience.

### CABINET

The Flip-Foot is easily elevated into the raised position or dropped back to the flat position for maximum operating ease. To elevate the Flip-Foot, lift the forward portion of the cabinet, reach under and pull the rear edge of the Flip-Foot down and forward until it reaches its upright position. To remove the top half of the cabinet it is necessary to remove the two screws on the lower forward corner of each side of the cabinet and the two screws at the lower outside corners of the back. Then remove the cabinet top by lifting and springing the front top lip of the cabinet free from the retaining clips attached to the panel. The cabinet is replaced by reversing this procedure, taking care to engage the slots in the forward lip of the cabinet into the two clips welded to the rear of the top section of the panel. The bottom cover of the receiver may be removed by removing the two rear mounting feet and by removing the four retaining screws. The bottom cover may then be slipped to the rear removing it from under the Flip-Foot, allowing free access to the wiring of the receiver.

## RF GAIN

Adjusts the receiver RF and IF gain or "sensitivity". Usually used as a volume control with the AGC switch in the OFF position. This control also reduces the receiver gain and the S meter sensitivity when the AGC switch is on.

## S METER

Signal strength meter and tuning indicator. When RFG is fully clockwise an "S-9" reading is approximately equivalent to a 50  $\mu$ V input at the antenna terminals. The S meter operates whenever the AGC switch is turned on and the BFO switch is off.

## ANTENNA

Adjusts receiver input circuit for best antenna match on each band as indicated by maximum signal strength. This control should be adjusted each time a different band is selected.

## MAIN TUNING

Selects the desired reception frequency as indicated on the slide rule dial. Also used to set the pointer to the desired triangular set mark for proper bandspread dial calibration.

## AUDIO GAIN

Controls the receiver output level by setting the gain of the audio amplifier. The switch turns the entire receiver on and off.

## PHONE JACK

Earphone jack silences speaker when earphone plug is inserted.

## SELECTIVITY

Controls Q multiplier circuit to determine the best receiver bandwidth for existing signal conditions. The OFF position provides 8 Kc. bandwidth for full fidelity AM reception. Best single sideband reception or AM reception under crowded band conditions will be obtained around 12 or 1 o'clock. Bandwidths of less than 150 cycles for best code (CW) reception are just below the point of Q multiplier oscillation at 2 or 3 o'clock.

## BANDSWITCH

Selects the desired tuning range. The dial scale which corresponds to the selected range is used to indicate the receiver tuning range.

## BANDSPREAD

Selects the desired reception frequency as indicated on bandspread dial, providing the main tuning dial is set to the appropriate set mark. Also used as a tuning vernier at any setting of the main tuning dial.

## DIAL SELECTOR

Selects bandspread calibration for either International Shortwave Broadcast or Amateur reception. To change the calibration pull the knob out and rotate one-half turn until the detent engages.

Adjusts the tuning of the beat frequency oscillator to control the pitch of CW signals. Set the pointer to USB to receive SSB signals using upper sideband transmission and LSB to receive SSB signals using lower sideband transmission. Should be offset for CW reception.

REC ANL BFO AGC  
 STBY OFF OFF OFF OFF

## REC-STBY SWITCH

Silences receiver during transmission periods. Instantly returns receiver to full operation with no warm-up required. Receiver may be externally controlled from calibrator socket.

## AGC-OFF SWITCH

Turns the automatic gain control circuits on or off. Automatic gain control may be used in AM reception. The S meter does not operate with the AGC switch in the off position.

## ANL-OFF SWITCH

Turns the automatic noise limiter on or off to minimize impulse type noise.

## BFO-OFF

Turns the Beat Frequency oscillator on for single sideband and CW operation.

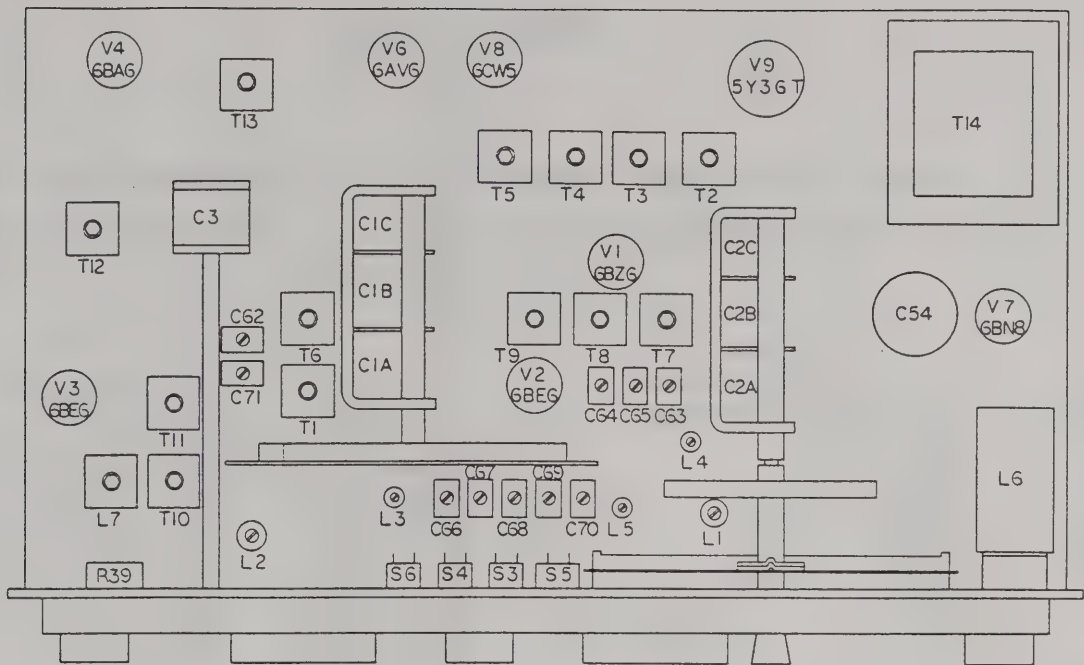

**ALIGNMENT LOCATIONS — TOP VIEW**

**DIAL CORD ASSEMBLIES**

**BANDSPREAD TUNING**

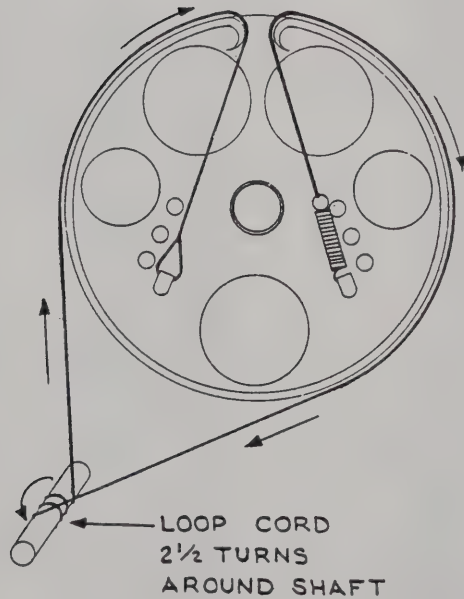

Dial cord installation as viewed from front of set with tuning capacitor at 50% mesh.

**MAIN TUNING**

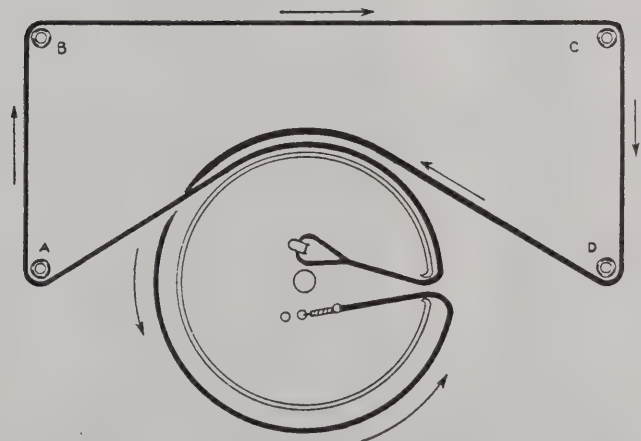

Dial cord installation as viewed from rear of set with tuning capacitor at maximum mesh.

# PARTS LIST

NC-140

ALL READILY AVAILABLE RESISTORS AND CAPACITORS ARE OMITTED FROM THE FOLLOWING PARTS LIST, BUT ARE COMPLETELY IDENTIFIED ON THE SCHEMATIC

A-12617	Panel Terminal (Speaker)		A-50148-52	Hose Clamp, BFO	
E-265-28	Panel Terminal (Antenna)		B-50188-4	Iron Core, BFO	
B-27669-3	Socket, 7 Pin		B-50470	Coil BFO	
B-27668-1	Socket, 9 Pin		A-50421	Spring Slug Screw, BFO	
B-27674-1	Socket, Octal		B-K641-20	Coil Shield, with Fasteners, BFO	
B-22025-3	Transformer, Output	T15	C-50437-5	Window, Main Tuning	
C-50719	Transformer, Power	T14	B-50631-1	Bandspread Dial Ass'y	
C-19458-5	Capacitor Electrolytic	C54	A-50439	Spring, Bandspread	
A-50137	Capacitor Mica Trimmer— 1.5-20 uuf	C62 through C71	B-50648-1	Assembly—Female Detent, Bandspread	
A-50408	Pulley Bracket, Dial Cord		C-50438-4	Dial Back Plate	
A-20165-2	Pulley, Dial Cord		B-50110-2	Pointer Rail	
C-50415-2	Main Tuning Capacitor	C1	C-50441-1	S Meter	
A-50448	Disc Drive, Main Tuning		C-50441-2	Clip Mounting, S Meter	
C-50423-2	Bandspread Tuning Capacitor	C2	B-50424	Pointer	
A-50501	Bracket, Light		B-19347-6	Dial Cord Ass'y, Main Tuning	
B-50466	Potentiometer S-Meter	R38	A-50118-1	Bushing Panel, Main Tuning	
B-50089	Potentiometer AF-Gain	R40	A-50117-1	Bushing Nut, Main Tuning	
B-50640	Potentiometer, Q Multiplier	R41	B-50407	Pinch Ass'y, Main tuning with flywheel and E rings.	
B-50092	Potentiometer RF-Gain	R39	B-19347-11	Dial Cord Ass'y Bandspread	
A-50263	Phone Jack		B-50688-4	Shaft Bandspread	
C-50412-2	RF Shield		A-20285-5	Flat "E" Ring, Bandspread	
C-50658	Switch, Band	S1	A-12346	Washer, Spring, Bandspread	
B-50095-2	Variable Capacitor, Antenna	C3	D-22500-X42-X-4AA	Knob Band	
B-50103	Transformer IF, 230 Kc.	T11, T13	B-50661-1	Bezel, Front Panel	
B-50641	Q Multiplier Transformer	T12	B-50661-2	Base, Bezel	
B-50209	Transformer 2215 Kc.	T10	B-50518-2	Knob, BFO with Set Screw	
B-50429	Coil Antenna—1.6-4 Mc.	T2	B-50519-2	Knob, RFG, ANT with Set Screw	
B-50452	Coil Antenna—4-10 Mc.	T3	B-50499	Knob Bandspread Chg.	
B-50451	Coil Antenna—10-20 Mc.	T4	D-22500-X42-X-4T	Knob, AFG and Selectivity	
B-50460	Coil Antenna—20-30 Mc.	T5	C-22034-49	Knob, Main Tuning and Bandspread	
B-50643	Coil, 2nd Oscillator	L7		Panel Lamp	V1
B-50430	Transformer Mixer—500-1600 Kc.	T1	NPL-47	6BZ6 Tube	V2, V3
B-50432	Transformer Mixer—1.6-4 Mc.	T6	6BZ6	12BE6 Tube	V4
B-50447	Transformer Mixer—4-10 Mc.	T7	12BE6	12BA6 Tube	V6
B-50453	Transformer Mixer—10-20 Mc.	T8	12BA6	12AV6 Tube	V7
B-50459	Transformer Mixer—20-30 Mc.	T9	12AV6	6BN8 Tube	V8
A-19405	Mounting Clips, Coil Cans		6BN8	6CW5 Tube	V9
B-50463	Coil Oscillator—500-1600 Kc.	L1	6CW5	5Y3-GT Tube	
B-50464	Coil Oscillator—1.6-4 Mc.	L2	5Y3-GT	Panel Lamp Socket Ass'y	
B-50465	Coil Oscillator—4-10 Mc.	L3	B-50300	Flip Foot	
B-50467	Coil Oscillator—10-20 Mc.	L4	B-50145-2	Rivets, Flip foot	
B-50469	Coil Oscillator—20-30 Mc.	L5	SR-125-B-14-N	Rivets, Flip foot	
B-17436-9	330 Ohms, 7 Watt Resistor	R34	A-50284-3	Push-on Tinnerman, Flip foot	
NCS-15-221-G-5	220 ±2% Mica Capacitor	C4, C10	A-50280	Glide	
NCS-15-331-G-5	330 ±2% Mica Capacitor	C5, C11	A-50281-2	Rubber Foot	
NCS-15-991-G-5	990 2% Mica Capacitor	C14	D-50462-2	Bottom Cover Painted	
NCS-19-252-G-5	2500 2% Mica Capacitor	C15	D-50418-5	Cabinet Ass'y.	
NCS-15-821-G-5	820 2% Mica Capacitor	C16	B-50434-2	Switch Bracket	
NCS-15-351-G-5	350 2% Mica Capacitor	C17	B-50457-13	Switch AGC	
NCS-15-181-G-5	180 2% Mica Capacitor	C18	B-50457-3	Switch, ANL	
B-50473-1	Line Cord		B-50457-11	Switch BFO and STBY-REC	
D-50657-3	Front Panel		A-50030-7	Tinnerman Nut, Switch Bracket	

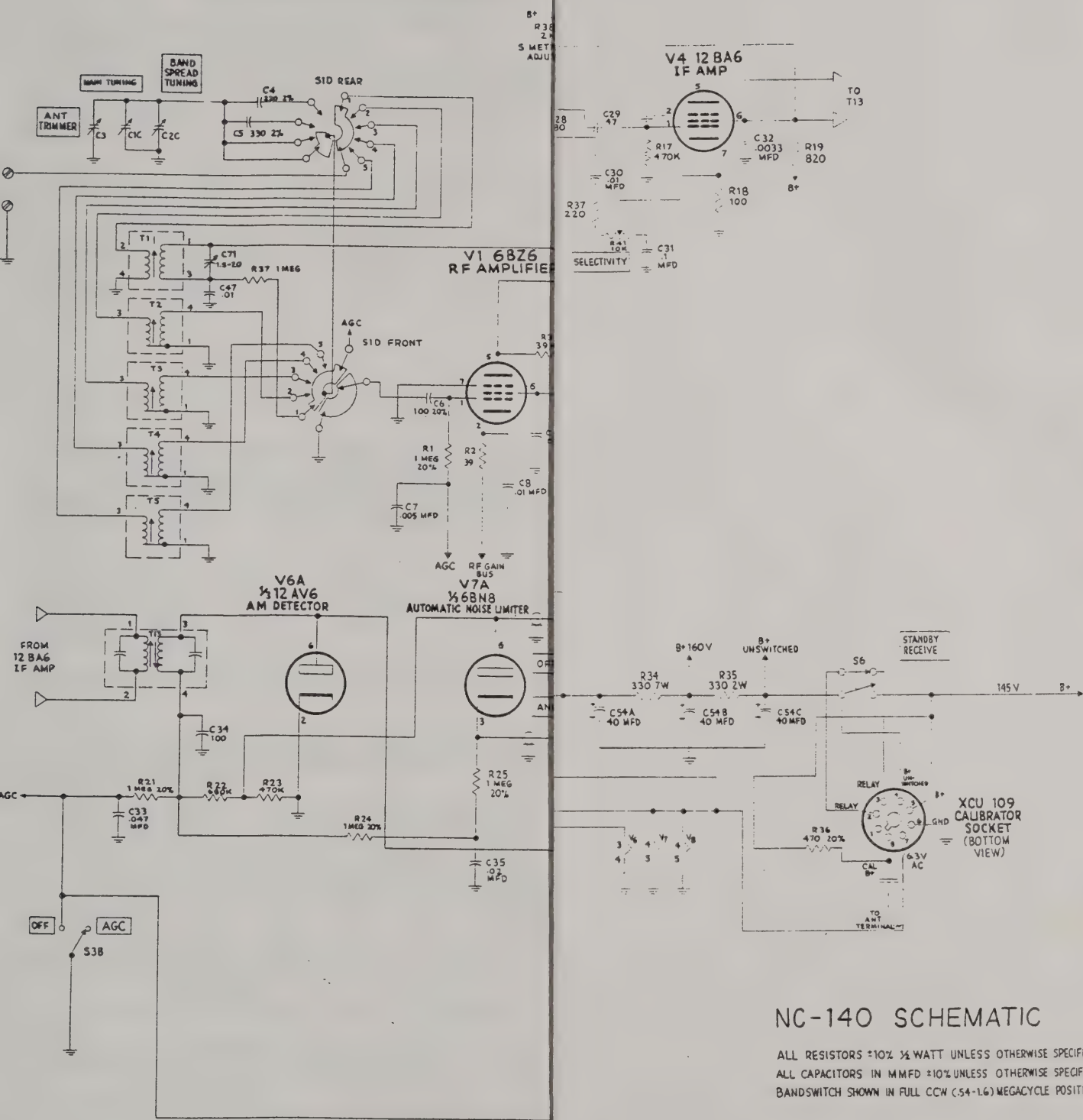

### NC-140 SCHEMATIC

ALL RESISTORS ±10% 1/4 WATT UNLESS OTHERWISE SPECIFIED  
 ALL CAPACITORS IN MMFD ±10% UNLESS OTHERWISE SPECIFIED  
 BANDSWITCH SHOWN IN FULL CCW (54-16) MEGACYCLE POSITION

# PARTS LIST

NC-140

ALL READILY AVAILABLE RESISTORS AND CAPACITORS ARE OMITTED FROM THE FOLLOWING PARTS LIST, BUT ARE COMPLETELY IDENTIFIED ON THE SCHEMATIC

A-12617	Panel Terminal (Speaker)		A-50148-52	Hose Clamp, BFO	
E-265-28	Panel Terminal (Antenna)		B-50188-4	Iron Core, BFO	
B-27669-3	Socket, 7 Pin		B-50470	Coil BFO	
B-27668-1	Socket, 9 Pin		A-50421	Spring Slug Screw, BFO	
B-27674-1	Socket, Octal		B-K641-20	Coil Shield, with Fasteners, BFO	
B-22025-3	Transformer, Output	T15	C-50437-5	Window, Main Tuning	
C-50719	Transformer, Power	T14	B-50631-1	Bandspread Dial Ass'y	
C-19458-5	Capacitor Electrolytic	C54	A-50439	Spring, Bandspread	
A-50137	Capacitor Mica Trimmer— 1.5-20 uuf C62 through C71		B-50648-1	Assembly—Female Detent, Bandspread	
A-50408	Pulley Bracket, Dial Cord		C-50438-4	Dial Back Plate	
A-20165-2	Pulley, Dial Cord		B-50110-2	Pointer Rail	
C-50415-2	Main Tuning Capacitor	C1	C-50441-1	S Meter	
A-50448	Disc Drive, Main Tuning		C-50441-2	Clip Mounting, S Meter	
C-50423-2	Bandspread Tuning Capacitor	C2	B-50424	Pointer	
A-50501	Bracket, Light		B-19347-6	Dial Cord Ass'y, Main Tuning	
B-50466	Potentiometer S-Meter	R38	A-50118-1	Bushing Panel, Main Tuning	
B-50089	Potentiometer AF-Gain	R40	A-50117-1	Bushing Nut, Main Tuning	
B-50640	Potentiometer, Q Multiplier	R41	B-50407	Pinch Ass'y, Main tuning with flywheel and E rings.	
B-50092	Potentiometer RF-Gain	R39	B-19347-11	Dial Cord Ass'y Bandspread	
A-50263	Phone Jack		B-50688-4	Shaft Bandspread	
C-50412-2	RF Shield		A-20285-5	Flat "E" Ring, Bandspread	
C-50658	Switch, Band	S1	A-12346	Washer, Spring, Bandspread	
B-50095-2	Variable Capacitor, Antenna	C3	D-22500-X42-X-4AA	Knob Band	
B-50103	Transformer IF, 230 Kc.	T11, T13	B-50661-1	Bezel, Front Panel	
B-50641	Q Multiplier Transformer	T12	B-50661-2	Base, Bezel	
B-50209	Transformer 2215 Kc.	T10	B-50518-2	Knob, BFO with Set Screw	
B-50429	Coil Antenna—1.6-4 Mc.	T2	B-50519-2	Knob, RFG, ANT with Set Screw	
B-50452	Coil Antenna—4-10 Mc.	T3	B-50499	Knob Bandspread Chg.	
B-50451	Coil Antenna—10-20 Mc.	T4	D-22500-X42-X-4T	Knob, AFG and Selectivity	
B-50460	Coil Antenna—20-30 Mc.	T5	C-22034-49	Knob, Main Tuning and Bandspread	
B-50643	Coil, 2nd Oscillator	L7	NPL-47	Panel Lamp	
B-50430	Transformer Mixer—500-1600 Kc.	T1	6BZ6	6BZ6 Tube	V1
B-50432	Transformer Mixer—1.6-4 Mc.	T6	12BE6	12BE6 Tube	V2, V3
B-50447	Transformer Mixer—4-10 Mc.	T7	12BA6	12BA6 Tube	V4
B-50453	Transformer Mixer—10-20 Mc.	T8	12AV6	12AV6 Tube	V6
B-50459	Transformer Mixer—20-30 Mc.	T9	6BN8	6BN8 Tube	V7
A-19405	Mounting Clips, Coil Cans		6CW5	6CW5 Tube	V8
B-50463	Coil Oscillator—500-1600 Kc.	L1	5Y3-GT	5Y3-GT Tube	V9
B-50464	Coil Oscillator—1.6-4 Mc.	L2	B-50300	Panel Lamp Socket Ass'y	
B-50465	Coil Oscillator—4-10 Mc.	L3	B-50145-2	Flip Foot	
B-50467	Coil Oscillator—10-20 Mc.	L4	SR-125-B-14-N	Rivets, Flip foot	
B-50469	Coil Oscillator—20-30 Mc.	L5	A-50284-3	Push-on Tinnerman, Flip foot	
B-17436-9	330 Ohms, 7 Watt Resistor	R34	A-50280	Glide	
NCS-15-221-G-5	220 ±2% Mica Capacitor	C4, C10	A-50281-2	Rubber Foot	
NCS-15-331-G-5	330 ±2% Mica Capacitor	C5, C11	D-50462-2	Bottom Cover Painted	
NCS-15-991-G-5	990 2% Mica Capacitor	C14	D-50418-5	Cabinet Ass'y.	
NCS-19-252-G-5	2500 2% Mica Capacitor	C15	B-50434-2	Switch Bracket	
NCS-15-821-G-5	820 2% Mica Capacitor	C16	B-50457-13	Switch AGC	
NCS-15-351-G-5	350 2% Mica Capacitor	C17	B-50457-3	Switch, ANL	
NCS-15-181-G-5	180 2% Mica Capacitor	C18	B-50457-11	Switch BFO and STBY-REC	
B-50473-1	Line Cord		A-50030-7	Tinnerman Nut, Switch Bracket	
D-50657-3	Front Panel				

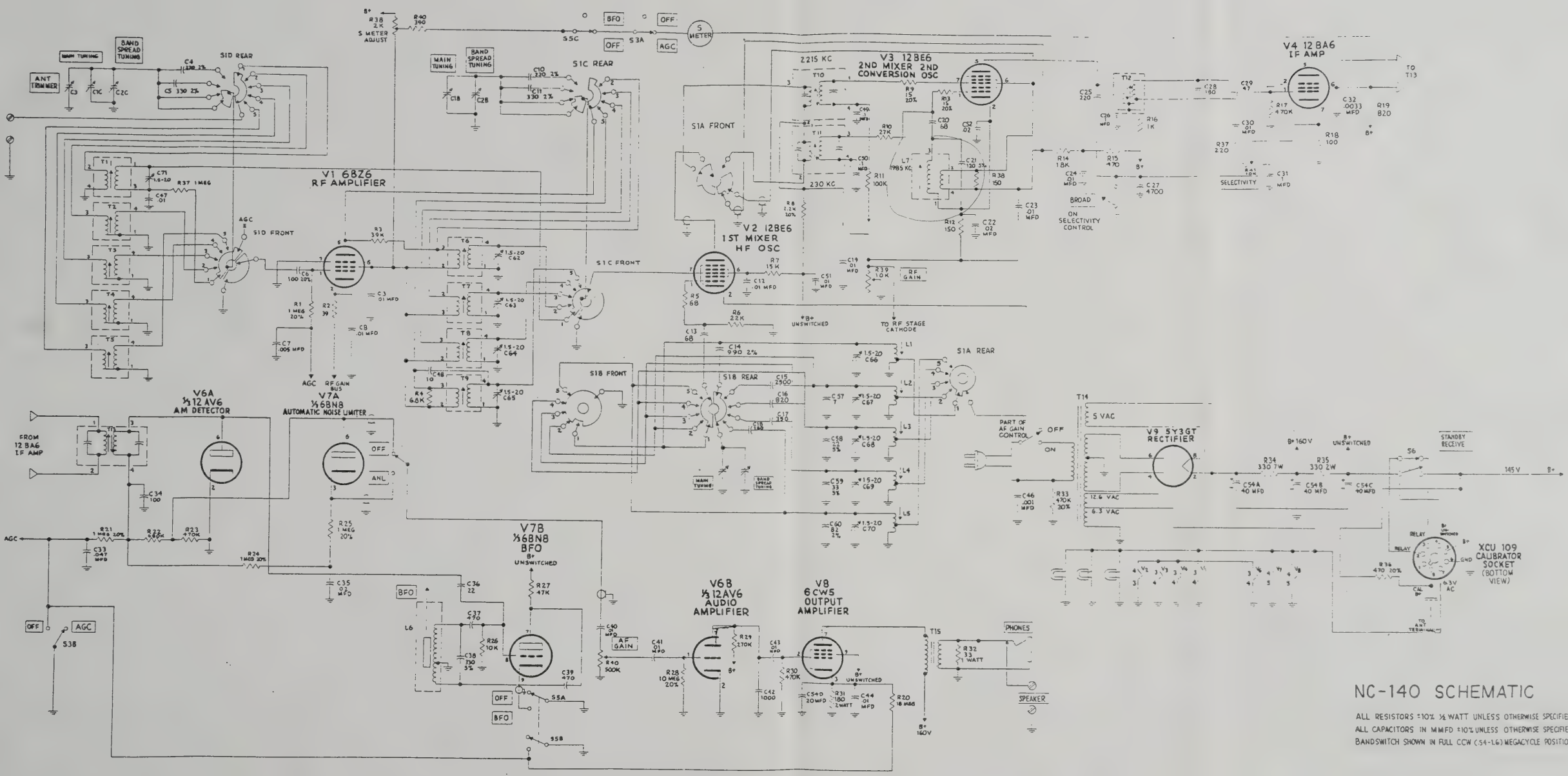

**NC-140 SCHEMATIC**

ALL RESISTORS ±10% 1/4 WATT UNLESS OTHERWISE SPECIFIED  
 ALL CAPACITORS IN MMFSD ±10% UNLESS OTHERWISE SPECIFIED  
 BANDSWITCH SHOWN IN FULL CCW (S4-L6) MEGACYCLE POSITION



## NC-140 ALIGNMENT INSTRUCTIONS

Alignment of the NC-140 receiver should be made only by persons familiar with communications receivers and experienced in their alignment. Refer to Alignment Location Figure for location of all adjustments.

### EQUIPMENT REQUIRED

1. Signal generator covering 200 Kc. to 35 Mc.
2. Vacuum tube voltmeter (VTVM)
3. Output meter. The AC scale of the VTVM can be used.
4. Tuning Wand — General Cement No. 8278 or equivalent.
5. Hex Alignment — General Cement No. 5097 or equivalent.

### INITIAL CONTROL SETTINGS

STBY-REC.....Receive	Selectivity.....Broad
ANL.....Off	Antenna.....Mid-Range
AGC.....Off	Bandspread.....At "Set" Point
BFO.....Off	Main Tuning.....At minimum capacity
Bandswitch.....As indicated in chart	Dial Selector.....Amateur Bandsread
RF and AF Gain.....Fully Clockwise	

### 230 KC IF ALIGNMENT

Signal Generator Connections	Signal Generator Frequency	Bandswitch Setting	Output Connections	Remarks
High side directly to mixer section of tuning gang. Low side to chassis.	230 Kc. (unmod.)	Broadcast Band	VTVM DC probe to junction of R21 and C34. Low side to chassis. (Topside of diode load)	Peak both sides of T11, T13, and top of T12. For bottom of T12 see Q MULTIPLIER ADJUSTMENT. Maintain approximately 2V reading on VTVM. Rock generator for maximum output. Maintain approximately 2V reading on VTVM. Set BFO switch on. Adjust L6 to zero beat. Loosen BFO knob set screw. Set BFO knob to center mark on panel. Then tighten set screw and return BFO switch to Off position.

### Q MULTIPLIER ADJUSTMENT

Set signal generator at BFO zero beat frequency as indicated in 230 KC IF ALIGNMENT.

Turn selectivity control clockwise until beat note is heard. Then turn control slowly counter-clockwise until the beat note just ceases. Re-set the bottom core of transformer T12 for maximum output. Adjust the generator output and selectivity controls as necessary to maintain 2V reading on VTVM at just below oscillation point. Turn selectivity control back to Broad position.

### 2215 KC IF ALIGNMENT

High side directly to mixer section of tuning gang. Low side to chassis.	2215 Kc. (unmod.)	4-10 MC	VTVM DC probe to junction of R21 and C34. Low side to chassis.	Set generator frequency to 2215 Kc. Set L7 for maximum output. The second peak from the bottom of the coil should produce the correct oscillator frequency of 1985 Kc. Peak top and bottom of T10. Maintain approximately 2V reading on VTVM.
--	----------------------	---------	--	---

### RF ALIGNMENT

Before proceeding with RF Alignment, check dial pointer for proper indexing. With tuning gang fully closed, set the pointer so that it reads exactly "0" on the logging scale. With bandsread capacitor fully closed, adjust dial disc to the exact low frequency end of the calibrated scales. Then open bandsread capacitor to "Set" mark.

*General Instructions* — The signal generator should be connected to the Antenna terminal through a 68 ohm ½ watt resistor. Ground generator to chassis. The oscillator circuits should always be adjusted first for proper dial calibration at the specified frequencies on each band. Then the mixer and RF circuits should be set for maximum output. A certain amount of interaction may occur between oscillator and RF adjustments. Final adjustment should be made for correct calibration. The trimmer adjustments should always be the final adjustment for each band. The oscillator frequency is always on the high side of the signal frequency. Suitable precautions or checks should be used to insure this condition.

Bandswitch Setting	Generator and Receiver Frequency	Adjustments
.54-1.6 MC (Broadcast)	.6 MC 1.5 MC	L1 for correct calibration, T1 for maximum output. C66 for correct calibration, C7 for maximum output.
1.6-4.0 MC	1.8 MC 4.0 MC	L2 for correct calibration, T6, T2 for maximum output. C67 for correct calibration, C62, Ant. Trim. for maximum output.
4.0-10.0 MC	4.0 MC 10.0 MC	L3 for correct calibration, T7, T3 for maximum output. C68 for correct calibration, C63, Ant. Trim. for maximum output.
10-20 MC	11.0 MC 20.0 MC	L4 for correct calibration, T8, T4 for maximum output. C69 for correct calibration, C64, Ant. Trim. for maximum output.
20-30 MC	20.0 MC 30.0 MC	L5 for correct calibration, T9, T5 for maximum output. C70 for correct calibration, C65, Ant. Trim. for maximum output.





