

INSTALLATION AND OPERATING INSTRUCTIONS

GONSET VHF POWER AMPLIFIER

MODELS 3063, 3065, 3067

RECEIVED
JUN 30 1958

WARNING

Over 1000 volts is employed on this amplifier, and it is very dangerous to work on out of cabinet. Always pull the a-c cord and short the high voltage supply to ground with an insulated screwdriver to discharge the filter condensers before attempting to work on it.

HENRY RADIO

TVI

If TVI is caused to channel 2 when operating on the 50-54 Mc. band, due to lack of selectivity in nearby TV receivers, it can be reduced or eliminated by addition of a Drake model TV-300-HP filter at the antenna terminals of the TV receiver.

WARRANTY

The Gonset Company warrants this product to be free from defective material and workmanship when new, and will remedy any defect or replace any defective part other than the vacuum tubes free of charge for a period of 3 months from date of original purchase, provided warranty registration card is filled in and mailed to us. This warranty does not apply to units which have in any way been abused or misused, either deliberately or accidentally, or have been altered.

The defective unit or part must be returned to us transportation charges prepaid, after first getting authorization to return.

No dealer or other person is authorized to assume any further liability on our behalf when selling this unit.

Made in U.S.A.

801 S. MAIN ST.



BURBANK, CALIF.

Gonset

VHF Power Amplifier

GENERAL

The Gonset VHF linear power amplifier is designed to (1) increase the carrier power of an amplitude-modulated, low-powered VHF radiotelephone transmitter, such as the Gonset Communicator, to a level of 50 to 60 watts, or (2) increase the carrier power of a low powered FM or CW VHF transmitter to nearly 100 watts. Approximately 4 to 5 watts is required to drive the amplifier to the full output, but the amplifier can still be used where as little as 3 watts is available. In the latter case the power output will be reduced slightly.

The amplifier includes an antenna changeover relay which is automatic in operation. The relay coil is connected in the negative high voltage lead in such a manner that application of enough excitation to cause approximately 90 ma. of plate current to flow will actuate the relay armature. This requires a minimum of approximately 3 watts driving power for positive operation.

It is important to note that the PLATE VOLTAGE IS APPLIED TO THE TUBES AT ALL TIMES (both transmit and receive) so long as the primary switch is in the "on" position.

INSTALLATION

The amplifier is shipped with all tubes removed from their sockets. All tubes should be inserted in their sockets and the back screen then attached to the cabinet with the screws supplied.

If a Phillips head screwdriver is not available for inserting the screws that hold the back, a small conventional screwdriver having a narrow blade will serve the purpose.

Installation is accomplished by connecting the amplifier to the antenna, connecting the amplifier to the receiver and driver by means of the cables furnished, and plugging in the 115 volt cord. It is recommended that the amplifier be connected to a load at all times it is turned on, because of high r-f voltages that may build up across the antenna output circuit under certain conditions of tuning when there is no load on the amplifier. For best operation the amplifier is designed to feed a 50 ohm line having a VSWR of not more than 2.0.

When the amplifier is employed with a Gonset COMMUNICATOR it is necessary to remove the back cabinet screen of the COMMUNICATOR. The cables furnished mate with the connectors on the COMMUNICATOR. The small coax with Motorola type connector pushes into the receptacle on the rear portion of the receiver, after first pulling out the cable terminating at this connector. The COMMUNICATOR may be operated with back removed, or, if preferred, a small "U" slot may be cut to permit replacing the back screen.

The large coax cable furnished connects from the regular (top) antenna connector on the COMMUNICATOR to the "input" receptacle on the amplifier.

OPERATION

The amplifier is so designed that so long as the driving power is limited to approximately 6 watts, nothing can be damaged under any possible conditions of mistuning, either accidentally or deliberately, providing that at least some load is connected to the amplifier to prevent r-f voltages from reaching excessive values across the antenna coupling components.

This means that when the amplifier is used with a COMMUNICATOR, one need only tune for maximum output (consistent with adequate modulation capability if for A-M telephony) without regard to plate current or grid current values. Because of its economy and because it is an r-m-s rather than an averaging device, a Mazda lamp is used as the output indicator. This lamp is coupled to the output circuit in such a fashion that when everything is adjusted and working properly it glows at about half normal brilliancy for 50 watts input into a 50 ohm load, and at near normal brilliancy for 80 to 90 watts output (as obtained on F-M).

Being an r-m-s indicating device, the lamp permits a check on the modulation capability. When the amplifier is used for A-M telephony, the idea is to adjust the antenna coupling and drive to obtain the greatest amount of brilliancy that can be obtained and still have the lamp "modulate upward" on speech. If the drive is excessive or the loading insufficient, the upward modulation capability will be restricted and the lamp will not "modulate up".

If a more quantitative check on the modulation is desired on A-M, a scope should be employed. However, the very simple method described will result in a near-optimum adjustment satisfactory for all but the most critical. For F-M operation one simply tunes for maximum output (lamp brilliancy) without regard to upward modulation capability.

Where more than approximately 6 watts of drive is available, it is possible under some conditions of tuning adjustment to cause the tubes to draw excessive plate current. This will be evidenced by the tube anodes showing a yellow color, rather than orange, when viewed through the window. If more than 6 watts drive is available, it is best to insert a 0-250 or 0-300 ma. d-c meter in the meter jack the first time the unit is tuned up. Total cathode current should be limited to approximately 225 ma. maximum. After observing the color of the tube plates under conditions of proper tuning, the amplifier subsequently can be tuned up safely by utilizing the tube anode color as an indication of approximate plate dissipation.

INITIAL TUNE-UP

When tubes are inserted and all connections properly made, the first requirement is to concurrently tune the output circuit of the r-f driver and the grid tuning control of the amplifier to get the

changeover relay to "kick in." Until some familiarity in tuning is had, it is recommended that a few "practice runs" be made using a 50 ohm dummy load in place of an antenna, keeping in mind that some readjustment of the amplifier plate tuning and load controls will be required when the transmission line is substituted for the dummy load unless the line happens to be absolutely flat (no standing waves at all).

If difficulty is had in getting the relay to close on initial tune up, turn the plate tuning control to another setting and repeat the procedure with the grid tuning.

Once the relay closes, the procedure for A-M telephony is simply to adjust the drive and antenna loading to give the greatest tuning lamp brilliancy that can be obtained and still have pronounced "upward modulation" when checked with a whistle into the mike. The plate tuning controls should always be adjusted to resonance, and the grid tuning condenser preferably so. However, it is permissible to adjust the grid drive by detuning the grid condenser if no convenient method of varying the output of the r-f driver is provided. **WHEN COUPLED TO AN ANTENNA RATHER THAN A DUMMY LOAD, MAKE THESE ADJUSTMENTS AS RAPIDLY AS POSSIBLE AND THE TESTING AS BRIEF AS POSSIBLE.**

If the amplifier is used as a power amplifier for a low power F-M transmitter, one simply tunes for maximum brilliancy of the tuning lamp without regard to "upward modulation". This will provide considerably greater carrier power for the same power input.

If the driving transmitter is capable of delivering more than approximately 6 watts into a 50 ohm load, then it is recommended that a 0-250 or 0-300 ma. d-c meter be inserted in the cathode jack during initial tune up, to avoid the possibility of excessive dissipation of the 826's or overloading of the rectifier tubes. Once one gets the "feel" of the amplifier and is familiar with the shade of orange color indicating normal dissipation on the 826's, the meter no longer need be used. Actually the tubes will withstand considerable overload for short periods of time, but continued overload is not to be recommended. The same applies to the rectifiers.

NEUTRALIZATION

The amplifier is neutralized at the factory and ordinarily the adjustment will hold indefinitely unless it becomes necessary to replace one or both 826's.

Neutralization is accomplished in the same manner as for any cross-neutralized push-pull amplifier. The neutralizing capacitors are of the "piston" type, with lead screw adjustment accessible through two holes in the bottom of the cabinet. The movable electrode is connected to the grid side in each case, so that there is no danger of electrical shock. However, to prevent detuning the grid tank and to be absolutely safe, only a plastic tool should be employed for adjustment. A piece of 1/4 inch polystyrene filed to a chisel point makes an excellent and inexpensive tool.

When the amplifier is properly neutralized, it will not self-oscillate at any setting of the plate tank condenser (excitation off). Another check is to remove the 5U4GB rectifiers, apply r-f excitation, insert an 0-25 or 0-50 ma. meter in the meter jack, and see if there is more than a barely perceptible flicker of the grid current as the plate tank condenser is tuned through resonance. This check is best made with a load on the amplifier, to simulate actual operating conditions for the plate tank.

If adjustment of the neutralizing capacitors is required, they should be moved in and out together to maintain circuit symmetry. Usually only a slight readjustment will be required when changing tubes.

BLOWER LUBRICATION

The blower motor should be lubricated about every 60 days with normal use; less frequently if seldom used and more frequently if used constantly. A couple of drops of medium-light machine oil should be applied to the oil hole at each end of the armature. The rear oil hole is reached by inserting the nozzle of the oil can through the meter jack on the rear of the chassis. This requires removing the chassis from the cabinet.

INDICATOR LAMP REPLACEMENT

Because of the frequency involved, it is not practical to employ a regular lampholder for the No. 47 Mazda output indicator lamp. Thus, should it require replacement, the new bulb must be soldered in.

The coupling to the indicator lamp may be adjusted, if desired, by reaching in with a polystyrene rod through the ventilation hole through which the link may be seen (near the rear of the antenna coax connector).

RELAY ADJUSTMENT

The relay is adjusted at the factory for proper operation and should not require attention for a long period of time, if ever. The relay should close on approximately 100 ma. cathode current, and drop out at not less than 70 ma. as the current through the winding is varied slowly between these limits.

If the armature takes over 100 ma. to pull in, then the loading spring should be stretched just enough to give the degree of tension that causes the relay to pull in at 100 ma. Do not attempt to get it to pull in at less than 90 ma. or it will not be possible to adjust it to open without reducing the current below 60 ma.

If the current through the coil must be reduced to less than 70 ma. to make the armature drop out, then the small adjusting screw must be screwed in (after first loosening the locknut) until the armature drops out at close to 70 ma. as possible. Check to make sure that both of the armature (swinger) contacts make positive contact with the "down" stationary contacts after the screw adjustment is made. If not, bend the stationary contacts as necessary, being careful not to put excessive strain on the ceramic insulation.

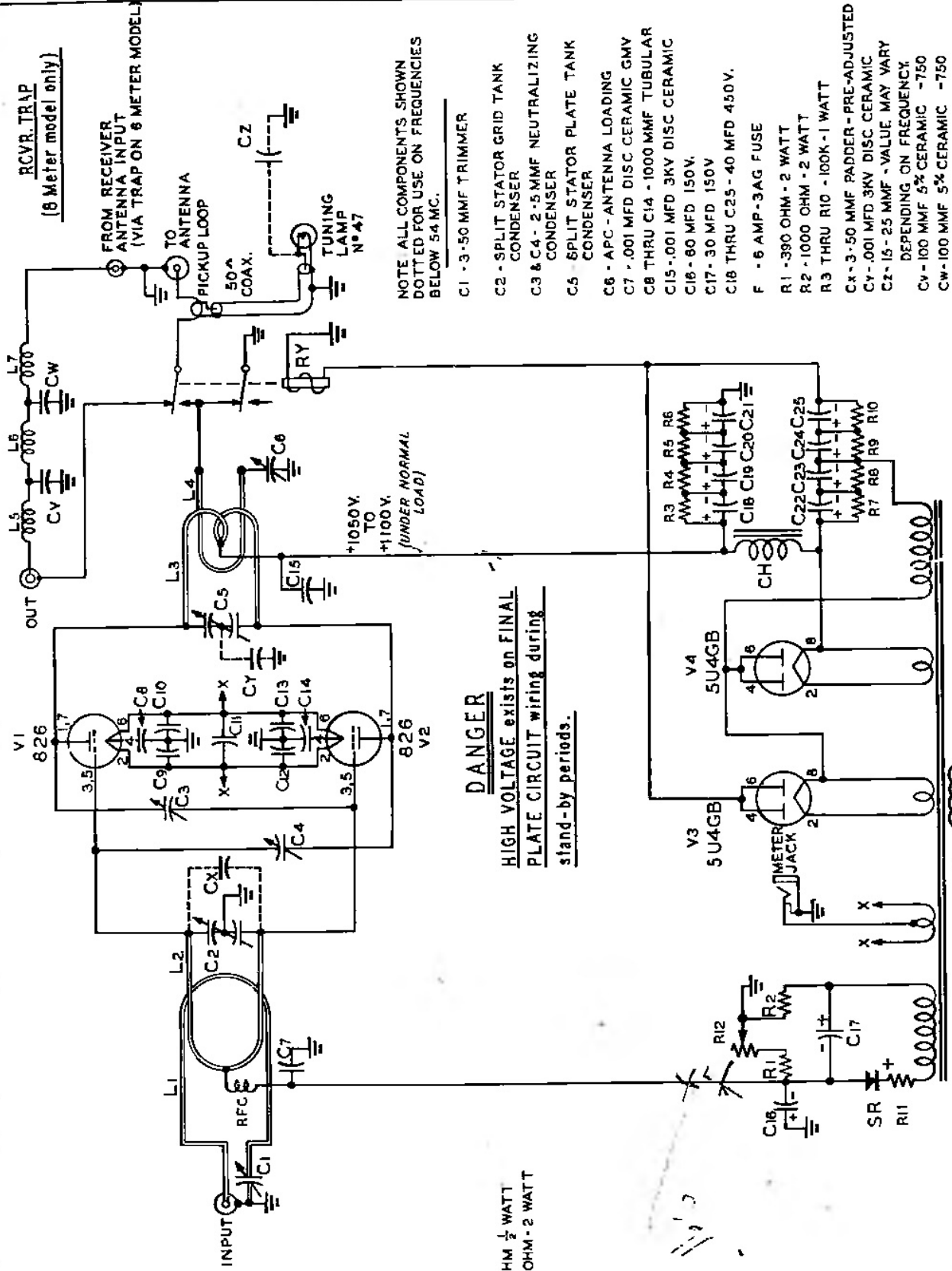

RCVR. TRAP
(6 Meter model only)

FROM RECEIVER
ANTENNA INPUT
(VIA TRAP ON 6 METER MODEL)

TO ANTENNA
PICKUP LOOP

50 Ω
COAX.

TUNING
LAMP
N°47

NOTE ALL COMPONENTS SHOWN
DOTTED FOR USE ON FREQUENCIES
BELOW 54 MC.

- C1 - 3.50 MMF TRIMMER
- C2 - SPLIT STATOR GRID TANK CONDENSER
- C3 & C4 - 2.5 MMF NEUTRALIZING CONDENSER
- C5 - SPLIT STATOR PLATE TANK CONDENSER
- C6 - APC - ANTENNA LOADING
- C7 - .001 MFD DISC CERAMIC GMV
- C8 THRU C14 - 1000 MMF TUBULAR
- C15 - .001 MFD 3KV DISC CERAMIC
- C16 - 80 MFD 150V.
- C17 - 30 MFD 150V
- C18 THRU C25 - 40 MFD 450V.
- F - 5 AMP-3AG FUSE
- R1 - 390 OHM - 2 WATT
- R2 - 1000 OHM - 2 WATT
- R3 THRU R10 - 100K - 1 WATT
- Cx - 3.50 MMF PADDER - PRE-ADJUSTED
- Cy - .001 MFD 3KV DISC CERAMIC
- Cz - 15 - 25 MMF - VALUE MAY VARY DEPENDING ON FREQUENCY
- Cv - 100 MMF 5% CERAMIC - 750
- Cw - 100 MMF 5% CERAMIC - 750

DANGER
HIGH VOLTAGE exists on FINAL
PLATE CIRCUIT wiring during
stand-by periods.

R11 - 27 OHM 1/2 WATT
R12 - 250 OHM - 2 WATT

+1050V.
TO
+1100V.
(UNDER NORMAL
LOAD)

**GONSET VHF LINEAR
POWER AMPLIFIER**

Model 3063 - 144 Mc. | CD Model 3089 - 144 Mc.
Model 3065 - 50 Mc. | CD Model 3090 - 50 Mc.
Model 3067 - Commercial Frequencies

BLOWER
(SEE OILING
INSTRUCTIONS)

115 V.A.C.