



Johnson

Outboards for '54

KNOWN AROUND THE WORLD FOR DEPENDABILITY

QUIETER

NOW! THE WORLD'S FIRST REALLY

Outboard Motor

The new Sea-Horse 5½ is the climax to years of Johnson effort to make outboard motors *quieter*. It started with the important development of Underwater Exhaust which Johnson introduced to outboard motoring in 1928. It progressed through the stages of advanced muffling, rubber cushioning and air silencing. Development continued ceaselessly, till

today Johnson gives you the ultimate—a motor with an entirely new type of construction. For the first time in outboard manufacture, the engine is free of the steel brackets—isolated by cushions. *This dissipates the vibration that creates the noise that you don't like . . .* Here is an historic development destined to change the whole complexion of outboard boating.

Antique Boat Museum

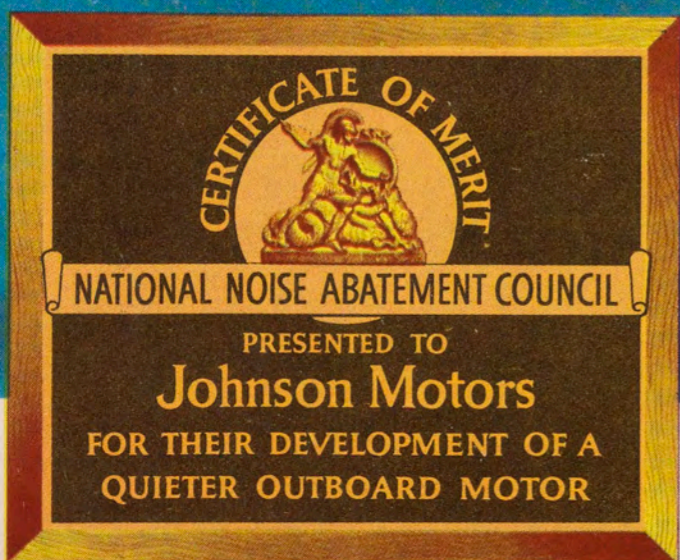

The Sea-Horse 5½ has the distinction of being the first outboard motor ever to win a citation from The National Noise Abatement Council.



SEA-HORSE
5½
 5½ HORSEPOWER

*Entirely New,
 Entirely Different*

This new motor you've got to try yourself! No one can tell you what it's like, because there has never been anything like it!

It's quiet. So quiet that conversation now becomes a part of outboard boating. So quiet that folks on shore hear the bow-lap above the sound of the motor. So quiet that it means the eventual revolution of all outboard manufacture. Motors that deafen are doomed!

And such quality performance you've never imagined! *Vibration is gone.* No more transom chatter. No more plank-sting. Truth is,

vibration is so thoroughly dissipated that you wonder if you're making speed—till you see the wake you leave behind!

The Sea-Horse 5½ has more modern developments than have ever before been concentrated in any outboard regardless of size—and its size is the most remarkable achievement of all! It follows the pattern of its famous predecessor—the Sea-Horse—which for years has been America's largest selling outboard. The 5½ has the same priceless handling ease, but even sweeter power—and more of it!

For specifications and construction features, see back cover.



Commercial fishermen everywhere have adopted Sea-Horse power—eloquent testimony to Johnson **DEPENDABILITY**, economy and long life!

Power flows to the keelson of your boat through resilient cushions, indicated by red arrows. This is Johnson's new Suspension Drive. It isolates your boat from the vibration that otherwise makes it a vast sounding board, that sets up "outboard drum." All that is transmitted to your boat is a surge of pure power—minus jitter, chatter, throb and noise.

But that's only the half of it! Through the introduction of resonating type silencers in the air intake and in the exhaust relief, the sharp explosiveness, characteristic of all outboards, is damped out at the source!

SUSPENSION DRIVE

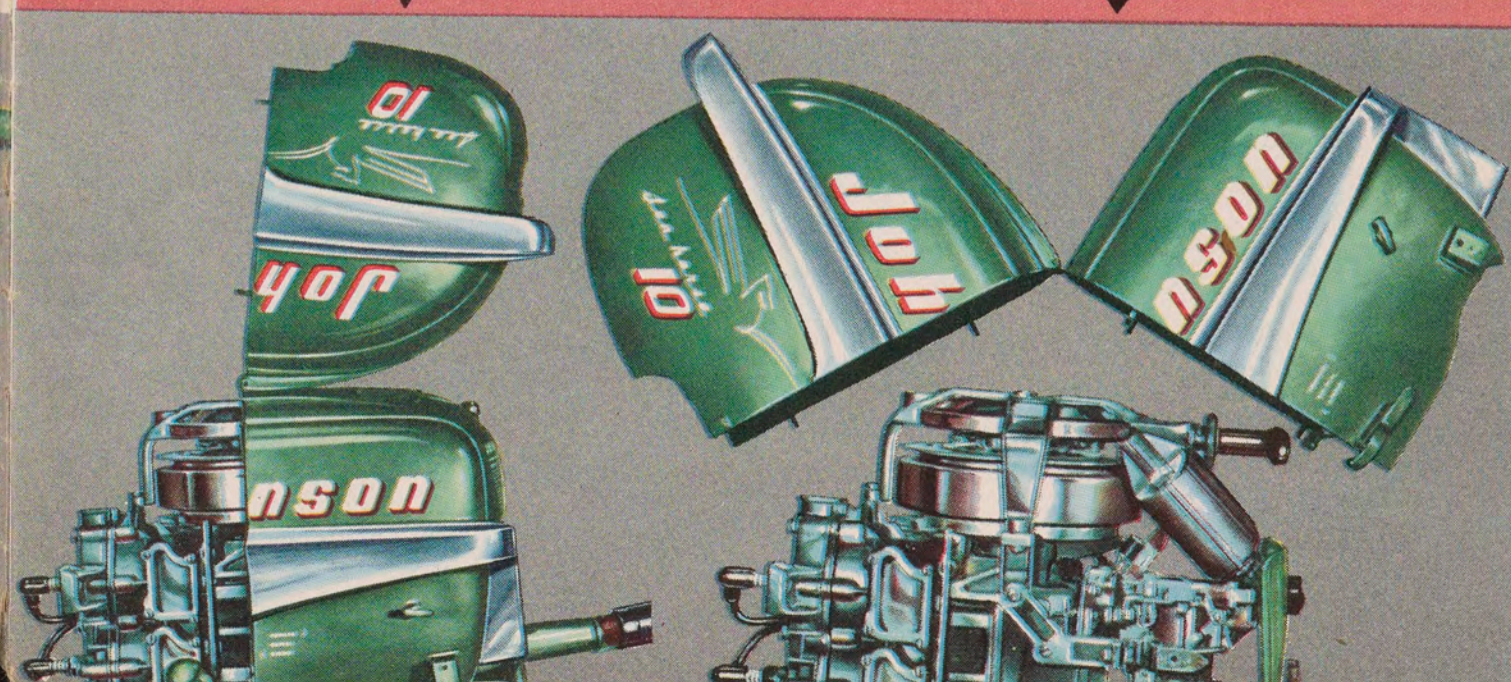
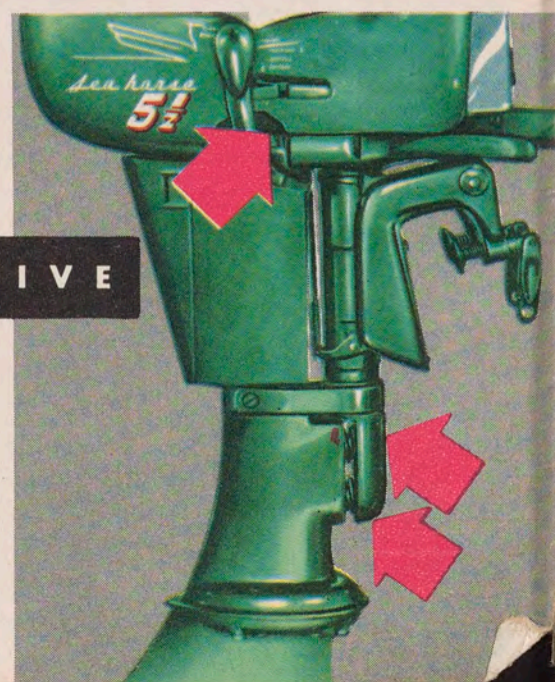

**NEW!
 REVOLUTIONARY
 QUIET**

**NEW!
 UP-AND-OFF
 MOTOR HOOD**

**NEW!
 NO VIBRATION**

**NEW!
 TWIST-GRIP
 SPEED CONTROL**

**NEW!
 FULL GEAR SHIFT
 NEUTRAL • FORWARD • REVERSE**

**NEW!
 MILE-MASTER
 FUEL SYSTEM
 (4 Gallons)**

IT'S UP!

Want to change a spark plug? Touch the snap releases and swing up the stern half of your hood—click—like that! In closed position you'd never know the hood lifted—it seats so solidly, holds so rigidly.

IT'S OFF!

And look! Turn two thumb screws and the entire hood comes off! Such accessibility has never before been known in a hooded outboard motor. It's Johnson's new Up-and-Off Hood, another modern feature of the "5½."

**NEW!
 5½ HORSEPOWER**

Antique Boat Museum



**ELECTRIC
STARTING
SEA-HORSE**

25

25 HORSEPOWER

Now! Push-Button Power

Talk about the "automatic outboard." This is IT! Here is everything that has made the Sea-Horse 25 sensational, PLUS JOHNSON-ENGINEERED ELECTRIC STARTING!

The Electric Starting Sea-Horse 25 is a complete unit—ready (except for battery) to spin into action at the first touch of the button—and still equipped for manual starting at any time. The starting drum is fitted with a Bendix Drive Electric Starter. The relays are housed in a special Control Box which is cable-connected to the choke and starter buttons on the Dash Panel. Nothing has ever been created to make outboard handling so simple, so convenient, so luxurious! And with Ship-Master Remote Control you have complete command. Sit down and relax. Your Sea-Horse will take care of itself.

For specifications and construction features, see back cover.



Johnson Sea-Horses have become great favorites of work boat operators who find their advantages in their flexibility, adaptability and economy. This "outboard motor" is powered by a twin engine "25" installation.

• 4 •

EVERYBODY IS CHOOSING THE SEA-HORSE 25 FOR CRUISING

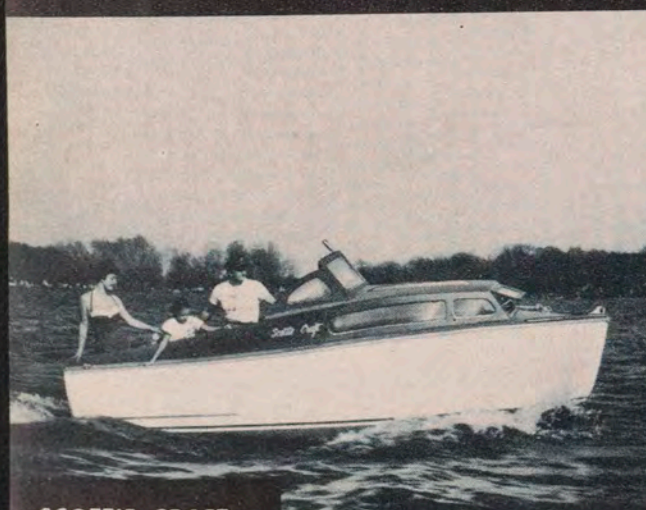

SCOTTIE CRAFT

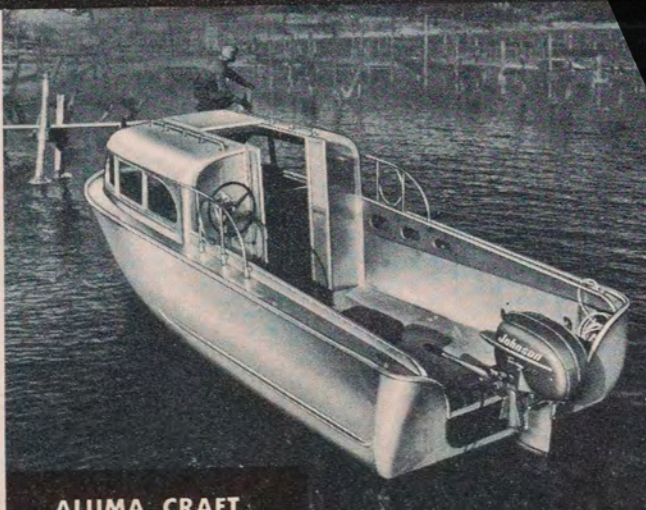

ALUMA CRAFT



OZARKA



WAGEMAKER



CHRIS CRAFT

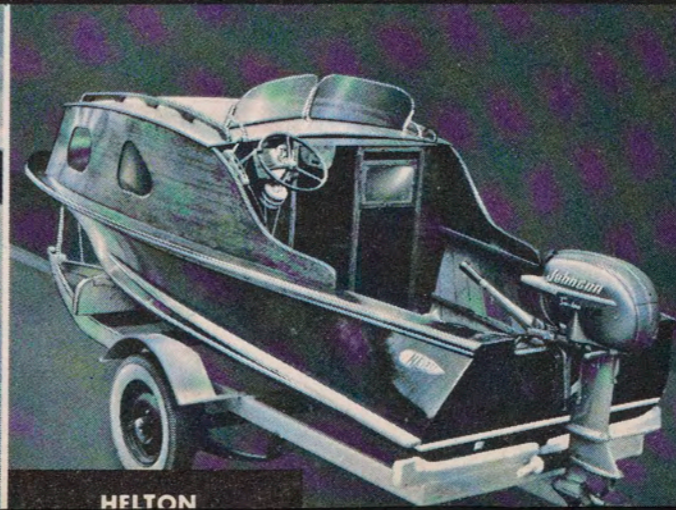

HELTON

... IT'S DEPENDABLE!

**NEW!
ELECTRIC
STARTING**

**SPEEDS OVER
30 M.P.H.
YET IT TROLLS!**

**FITTED FOR
SHIP-MASTER
REMOTE CONTROL**

**MILE-MASTER
FUEL SYSTEM
(6 Gallons)**

**FITTED FOR
FUEL-MASTER
SUPPLY SYSTEM**

**FULL GEAR SHIFT
NEUTRAL • FORWARD • REVERSE**

**TWIST-GRIP
SPEED CONTROL**



• 5 •



SEA-HORSE
25
25 HORSEPOWER

Simply Sensational!



Johnson's development of the Sea-Horse 25 started something in boating. Outboard runabouts have become smarter, abler, faster. Commercial operators have switched to outboard power for this motor's definite advantages of performance, flexibility and economy. And the outboard-cruiser dream has suddenly become a beautiful reality.

For here is everything. Big power—capable of driving staunch, sleek runabouts, fully loaded, over 30 m.p.h. in a self-contained unit that offers no problem of installation—that does not intrude upon precious space inside your boat, nor

add excessive weight. A big capacity, portable fuel system—no fittings necessary—that plugs into your motor "click"—and that is furnished with the motor's standard equipment—no extra cost. Easy shift, to direct the motor's power at will. And built-in fittings for Johnson's wonderful Remote Control which gives perfect shift-and-throttle operation from your steering wheel.

For three years Johnson has been building this sensational motor by the thousands. For three years Johnson has been unable to keep up with demand. Drive this motor—thrill to its performance—and you'll understand why.

For specifications and construction features, see back cover.

SPEEDS OVER
30 M.P.H.
YET IT TROLLS!

ONLY
99 POUNDS

FULL GEAR
SHIFT
NEUTRAL • FORWARD • REVERSE

FITTED FOR
SHIP-MASTER
REMOTE CONTROL

LOWEST PRICE
PER
HORSEPOWER

TWIST-GRIP
SPEED CONTROL

MILE-MASTER
FUEL SYSTEM
(6 Gallons)

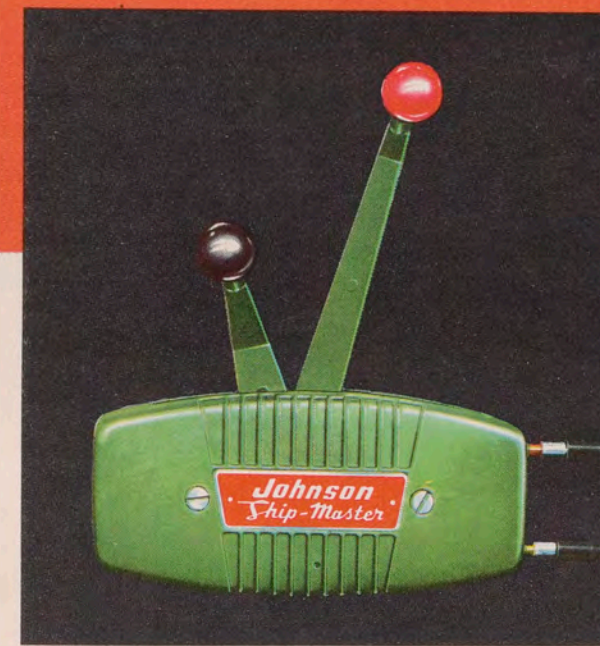

SHIP-MASTER

Smooth, dependable shift-and-throttle operation from your steering wheel is provided by Ship-Master Remote Control—an accessory—especially engineered for the Sea-Horse 10 and both Sea-Horse 25's.

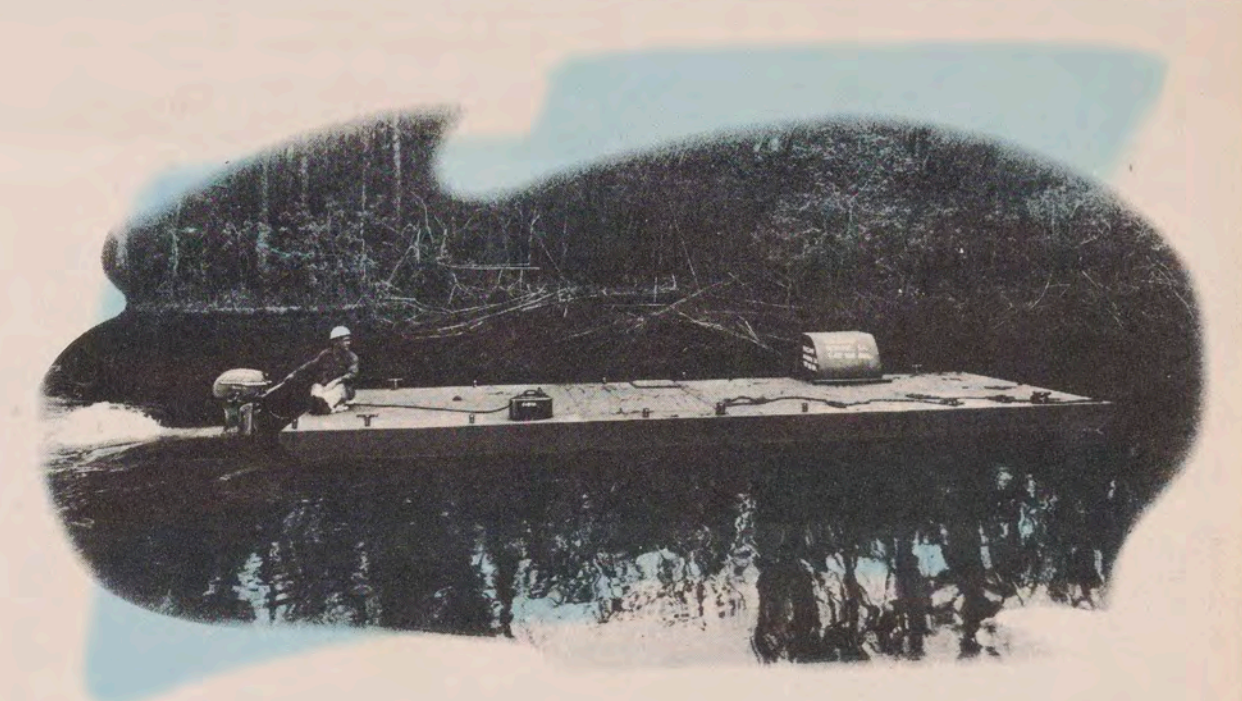

THE BIG TREND IN WATER TRANSPORTATION

More and more, the world's loads are being moved by Sea-Horse outboard motors as work boat operators discover the advantages of these modern, high-performance engines. Here a 30' x 15' barge, powered by a Sea-Horse 25, moves tons of oil through the shallows of Louisiana swamps—more swiftly, more surely, more economically than the job was ever done before.

GET ABOARD THE FASTEST-GROWING SPORT IN AMERICA—

IT'S FUN FOR ALL THE FAMILY

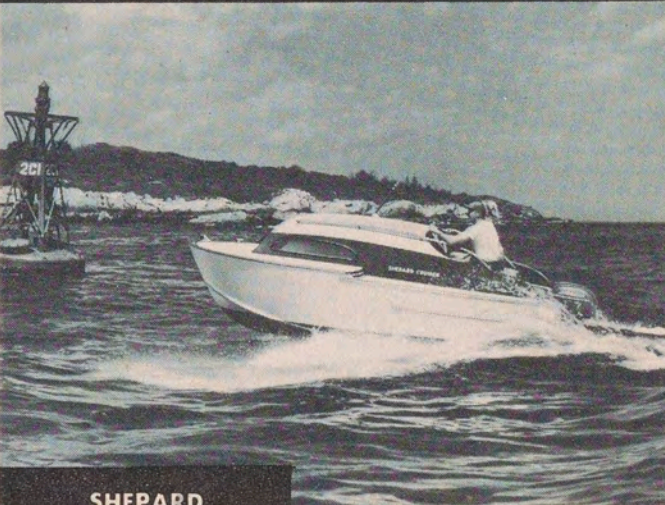
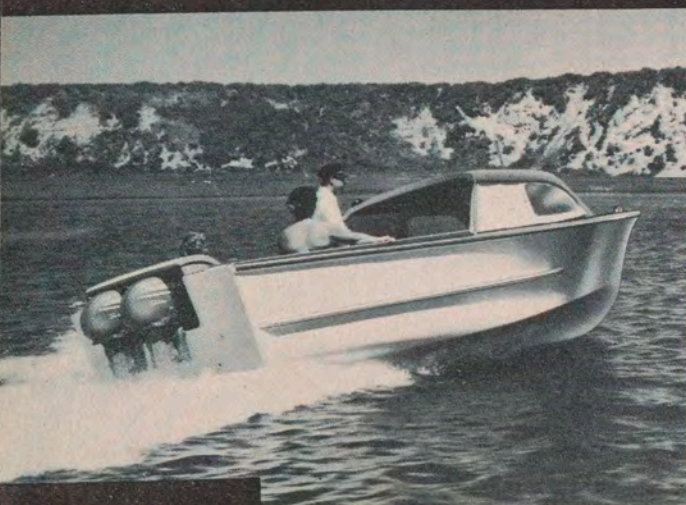

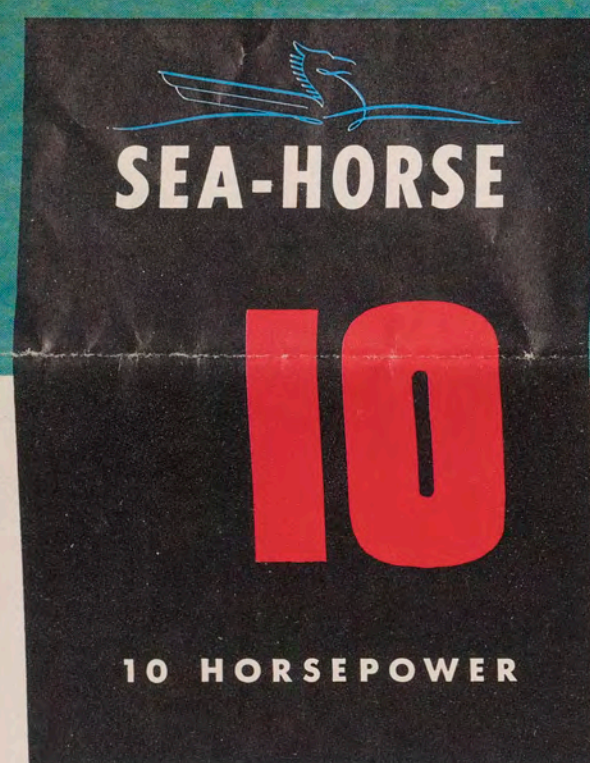
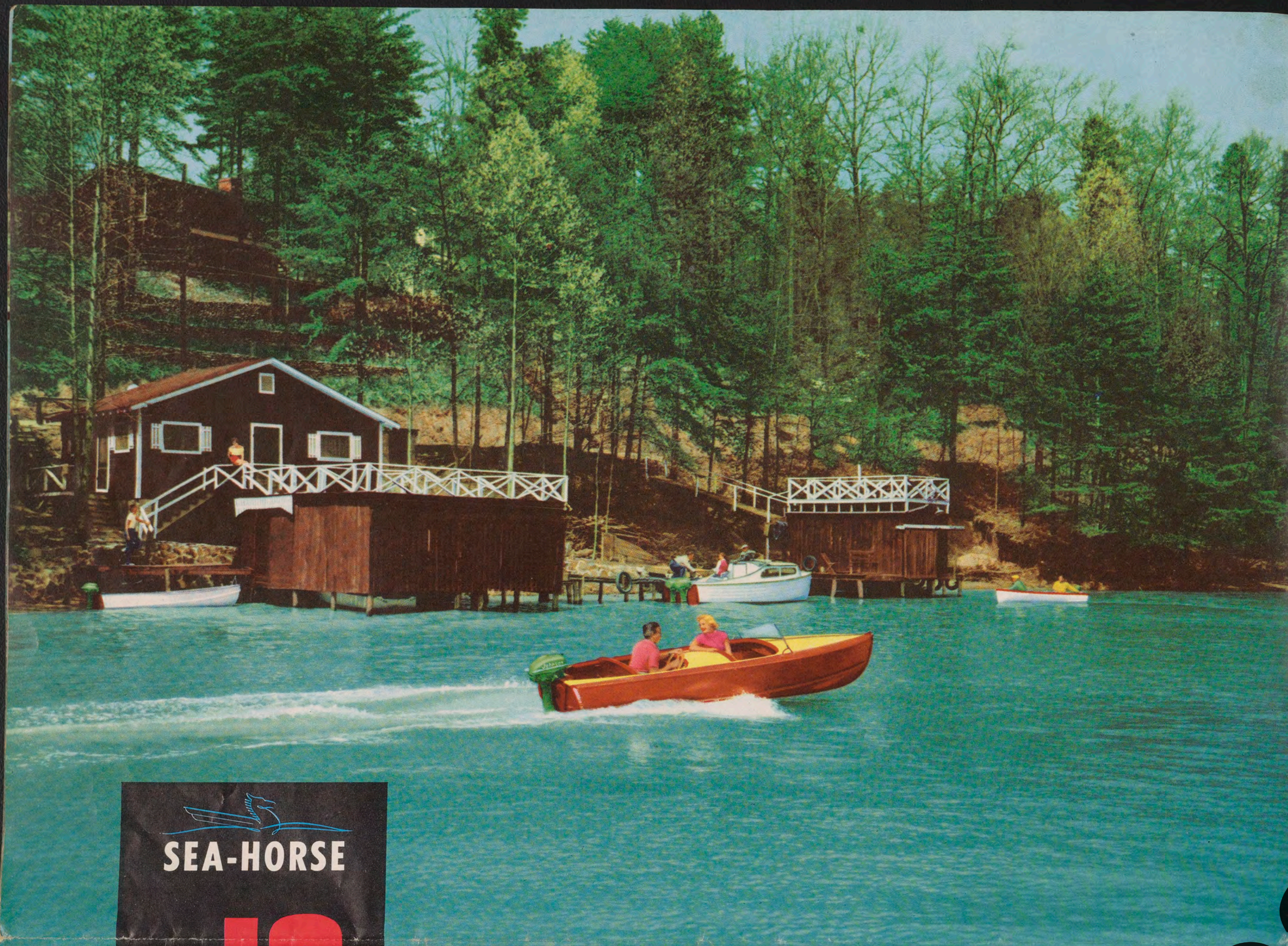

Now, Greater than Ever!

Here is the new improved version of the brilliant Sea-Horse model that is setting outboard motordom afire. Flashing power for flashing speed, in a compact unit that you can handle easily—and that gives spectacular performance!

Look at it in its smart new dress for 1954 . . . It's an eyeful to be proud of. Try its new Up-and-Off Motor Hood and learn what it's like to have easy, immediate access to your engine. And listen to it run. It speaks with all its old authority in a new and softer voice—due to the introduction of resonating type silencers in the air intake.



The Sea-Horse 10 is America's great all-purpose outboard. It has ample power to give you thrilling action on fast runabouts. And it is sized to delight the hearts of fishermen—compact and handle-able.

It is different—with a difference you can feel. High torque power, the result of extremely advanced outboard design, produces great thrust at lower speeds—which means you get terrific action all the way up. No lag—no sputter. Just roll your wrist—and hold your hat! . . . Cut your gas and your foot down to a crawl without missing a beat.

It's a thoroughly deluxe motor—with every feature to make outboard motoring easy and pleasant. Gear Shift, that simplifies handling. Mile-Master Fuel Tank, that carries separately, that plugs in and feeds automatically. You can run top speed for hours without refueling. Synchron Twist-Grip gives you full control of speed simply by twisting the grip of the steering handle. Built-in fittings accommodate the Johnson Ship-Master for operation of shift and throttle from your steering wheel.

There is one other important thing. This motor dramatically demonstrates the advantage of big and superior facilities for outboard manufacture. It is available at a price that plainly invites the widespread ownership it enjoys. Check. You'll see!

For specifications and construction features, see back cover.

SMART NEW
STYLING

UP-AND-OFF
MOTOR HOOD

CARBURETOR
INTAKE SILENCER

TWIST GRIP
SPEED CONTROL

SHIFTL GEAR
SHIFT
NEUTRAL • FORWARD • REVERSE

FITTED FOR
SHIP-MASTER
REMOTE CONTROL

MILE-MASTER
FUEL SYSTEM
(6 Gallons)

NEW AIR SILENCER!

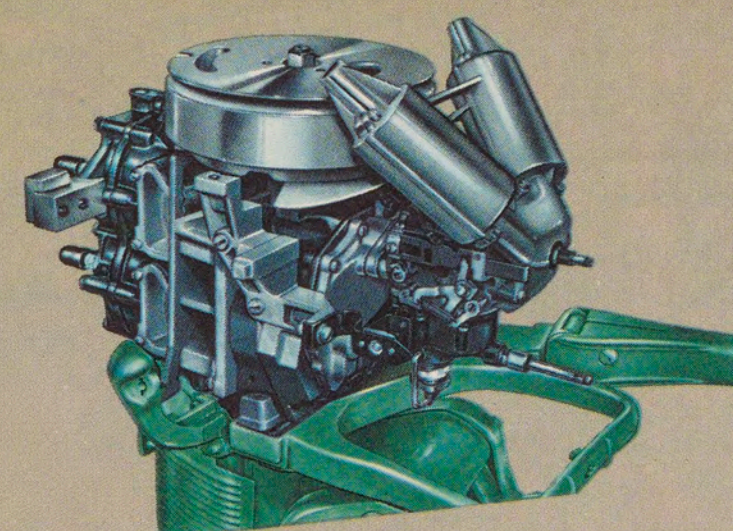

The high level of noise ordinarily created by outboard carburetor suction is effectively lowered in the Sea-Horse 10 through the introduction of a resonating type silencer. This damps out annoying pulsations, resulting in quieter operation.

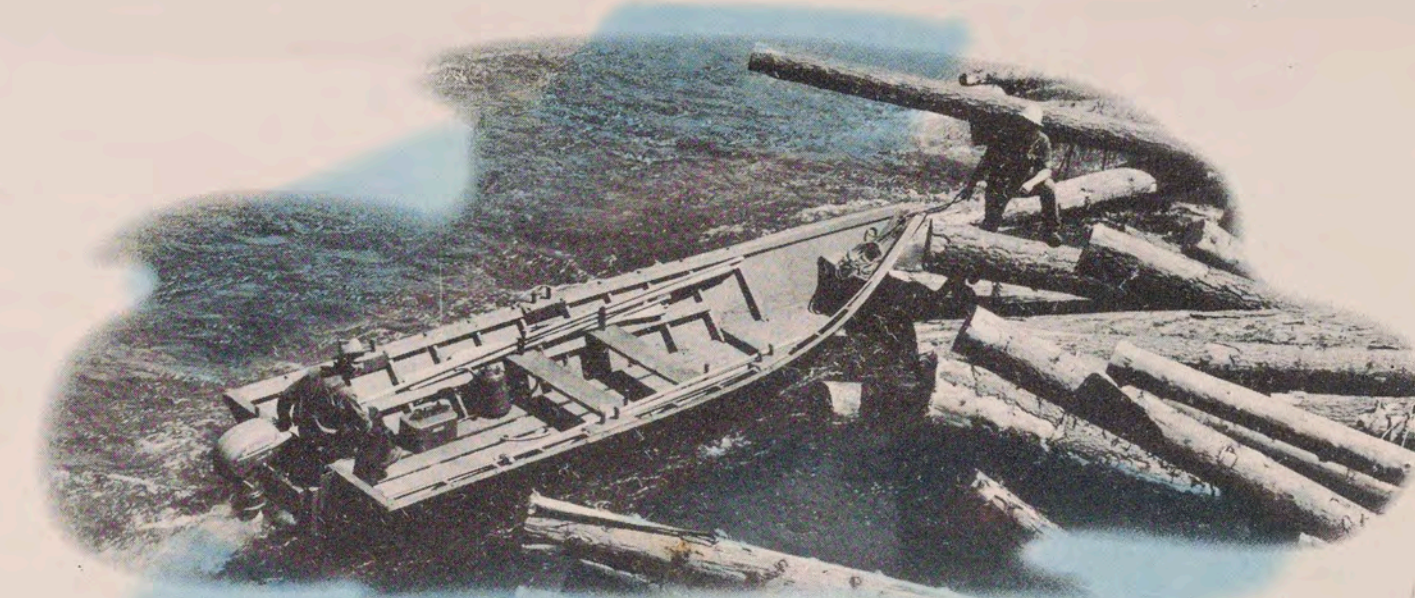

Sea-Horses are widely used in logging operations, where the hours are long and the going is tough. Here is one of three boats, all Johnson powered, used to ferry a 34-man crew in a mechanized log drive. Modern outboard responsiveness, flexibility and economy account for the ever growing use of Sea-Horses in this industry.



Amazing Performance

The Sea-Horse 3 will get you around in waters that are plain unfriendly to a motor with any other kind of drive. Angle-Matic is amazing!

There's more to it than the slant of the skeg. Note how the propeller is set to corkscrew through the thickest bed of weeds. Then note what happens when you drive in just a saucerful of water: the lower unit tilts, but your prop is still in position to deliver a forward thrust. Ask owners. Johnson Angle-Matic Drive (patented) is a feature that makes a small motor doubly valuable!

The Sea-Horse 3 has all the power it takes to drive you at a smart

clip in average fishing boats. Which is something to ponder—since its weight is only 32 pounds! Moreover, it's not a single—a Johnson Perfected Alternate Firing Twin. Nothing is smoother!

Everybody likes to handle this motor. It's nothing to lift. It totes like a tackle box—and stows out of the way almost as readily. Thousands of owners keep it in their boats—always on tap for fishin' wherever the sport is right.

Through and through, it's a Sea-Horse—with inherent Sea-Horse DEPENDABILITY. Same basic construction, even down to Johnson's famous 3-way protection against corrosion (plus stainless steel propeller, shaft, driveshaft and underwater screws). Such quality refinements as Air Intake Silencer and Rubber Cushioned Power Head are part and parcel of the "littles Sea-Horse." Don't let anyone tell you that you have to sacrifice quality to get light weight in an outboard. You get both in a Johnson.

For specifications and construction features, see back cover.



Reelfoot Lake where fish are fish—and the water is carpeted with vegetation. Makes no difference to Angle-Matic Drive. It goes anywhere!

**CARBURETOR
SILENCER**

**3 SOLID
HORSEPOWER**

**ALTERNATE FIRING
TWIN**

**ONLY
32 POUNDS**

**RUGGED,
DEPENDABLE**

**AMAZING
ANGLE-MATIC
DRIVE**

Johnson Angle-Matic Drive feels its way along like nothing else in power boating. It slides through weeds . . .

. . . and keeps going even in shallows that will barely float your boat! It's the drive with the magic touch . . .

. . . and it skis right over underwater obstructions. With this unusual drive you go along at full power.

Goes Where Others Dare Not Venture

• 11 •

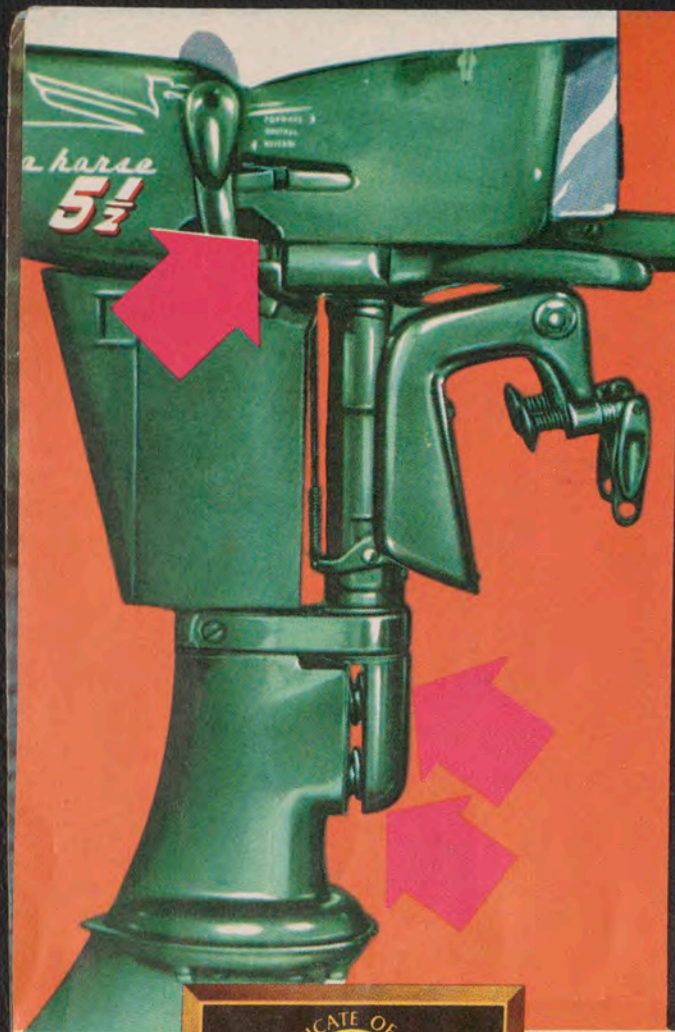

SUSPENSION DRIVE

Johnson's revolutionary outboard construction. This frees engine from stern bracket. Power flows through resilient cushions (see arrows) that prevent transfer of vibration to boat. Result—quiet! Sea-Horse 5 1/2 only.

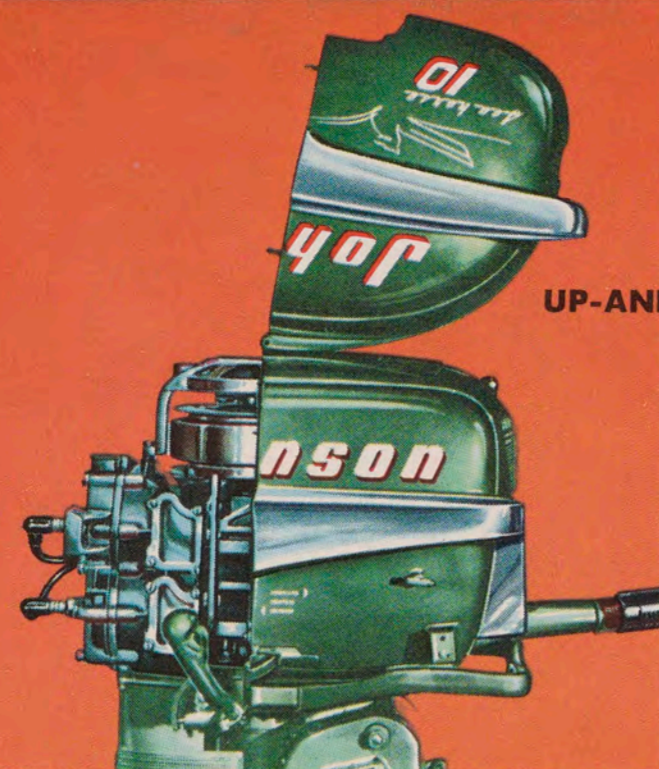

UP-AND-OFF MOTOR HOOD

It's wonderful—the hood with the 2-stage lift. Lifts up for instant access to stern half of engine, simply by opening snap release.

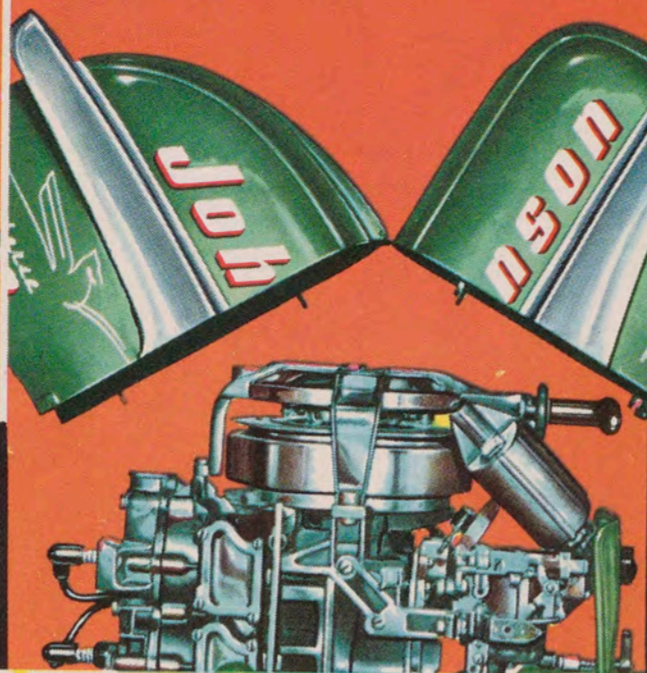

Turn two thumb-screws and entire hood lifts off. Rigid, solid seating. On Sea-Horses 5 1/2 and 10.

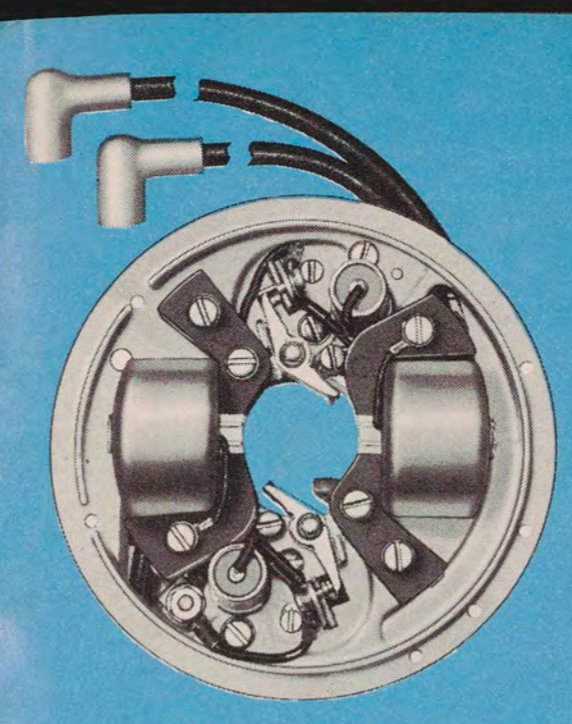
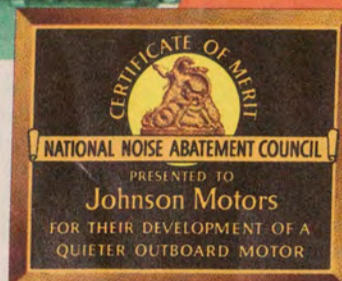

WATERPROOF IGNITION

Sealed! Coils are molded in plastic. High tension leads are rubber covered—sealed in plastic coil case. Condensers are sealed. Spark plugs protected with rubber shields. Johnson magnetos deliver, every time!

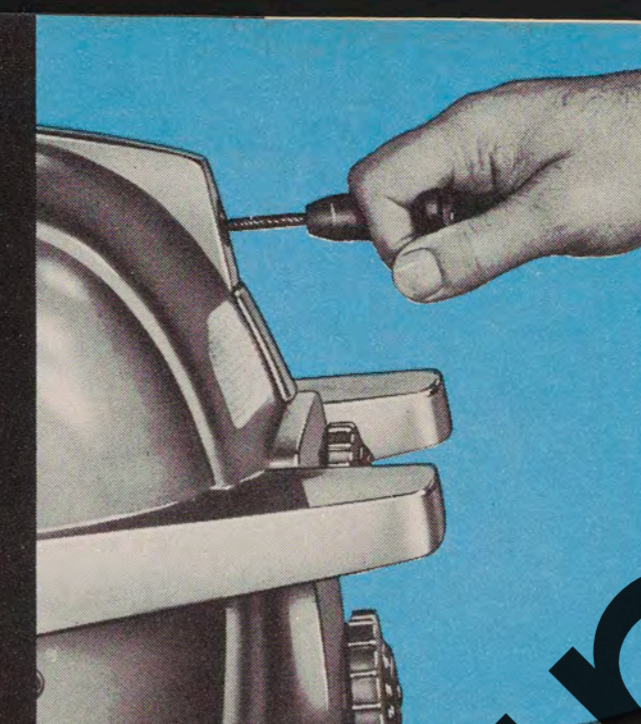

SEA-HORSE STARTING

The joy of every Johnson owner! No other type gas engine starts so sure, so easily. Shown above, Ready-Pull Starter—automatic, no wind. Oversize drum in the Sea-Horse 25.

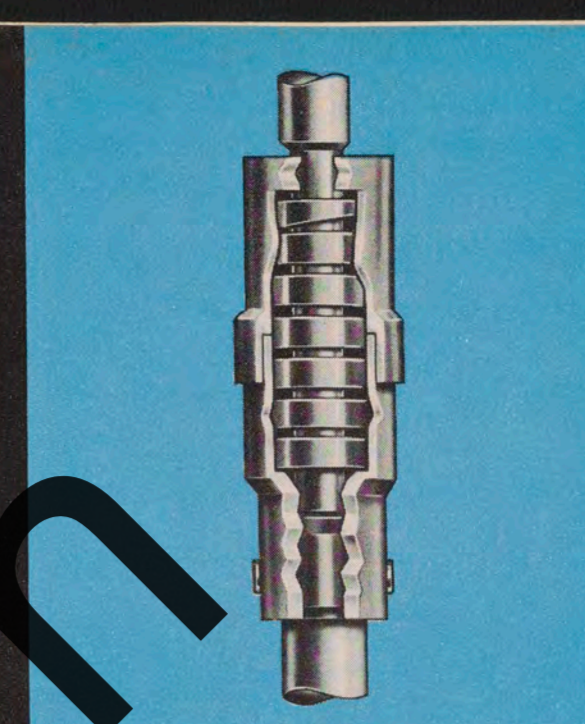

SHOCK ABSORBER DRIVE

The "educated" drive in the Sea-Horse 5 1/2 that lets go of the drive shaft when your prop hits an obstruction—and engages again when you're free. No shear pin! No fear of shearing one!

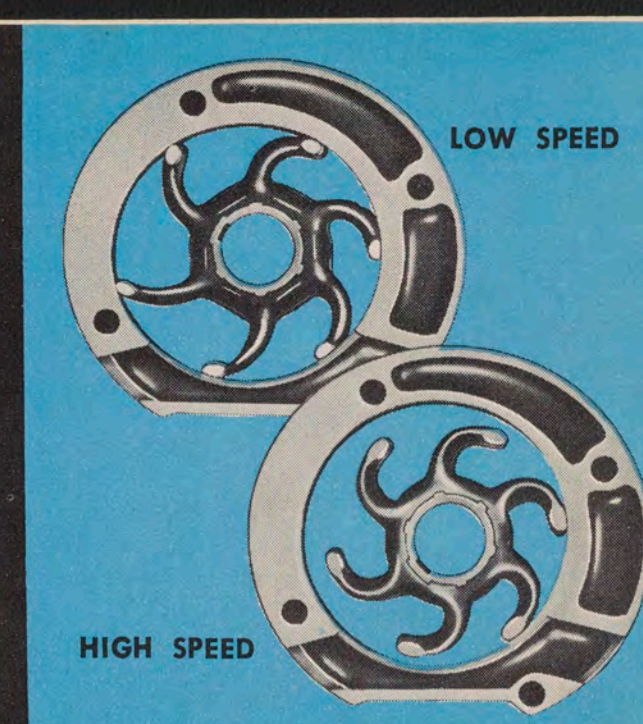

VARI-VOLUME WATER PUMP

Efficient cooling at all speeds—even in muddy or sandy water. Dual action. A positive displacement type at slow speeds. The rotors flex at higher speeds for high volume centrifugal action.

When you've got a **Johnson** you've got Outboard Motoring's Finest Features!

GEAR SHIFT...gears are always in mesh—no clash

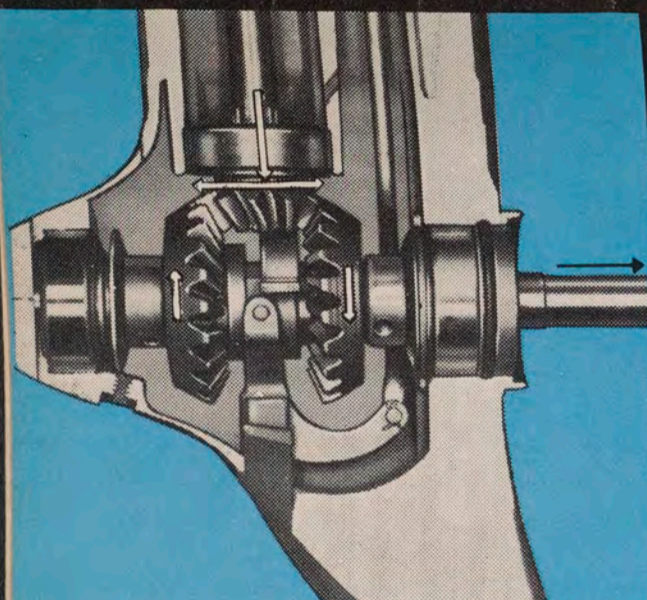

NEUTRAL. Gears are in motion but propeller shaft is disengaged... Automatic speed limitation in neutral, on higher horsepower motors.

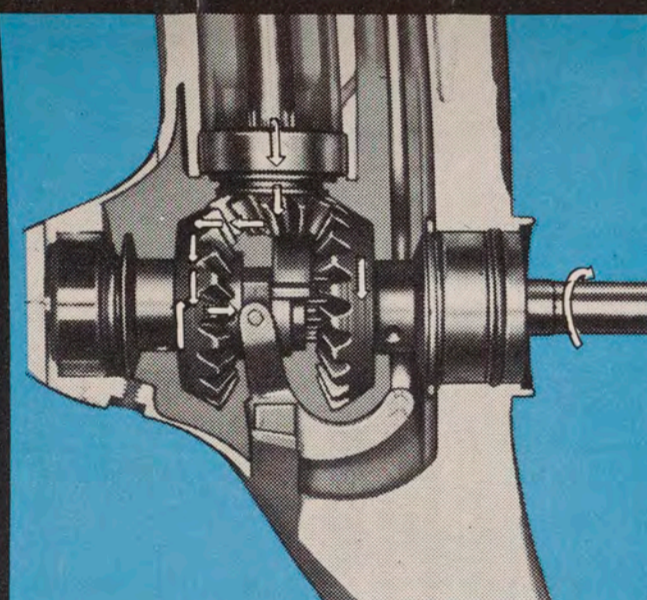

FORWARD. Propeller shaft engages rotation of forward gear. No clash... Spiral bevel gears insure quietness and long life.

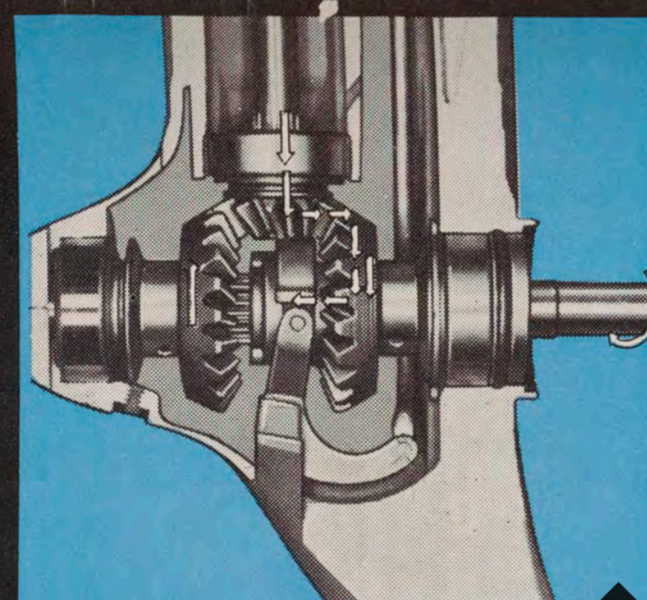

REVERSE. The shaft engages the rotating reverse gear. No clash. Also, rubber floated propeller cushions every shift.

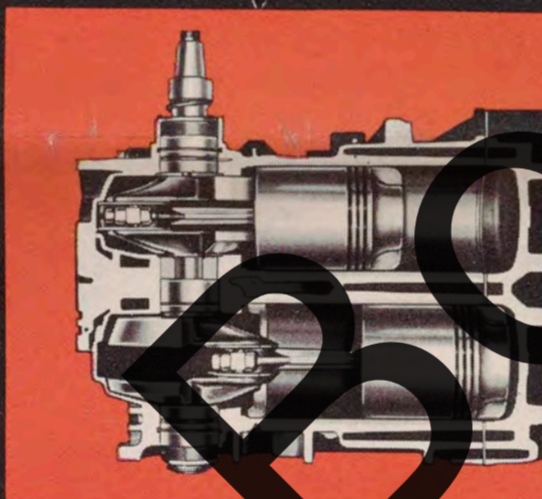

PERFECTED ALTERNATE FIRING

Outboard alternate firing was originated by Johnson and it is brought to its peak of perfection in Johnson Sea-Horses. Two impulses per revolution (8,000 to 10,000 per minute) level out the surge of power to a smooth, liquid flow!

TWIN GRIP HAND HOLDS

Man-size stern grip for balanced carry. Forward or rear motor-rest gives solid 3-point suspension when you lay motor down. Sea-Horse 25's have new Tilting Handle at rear.

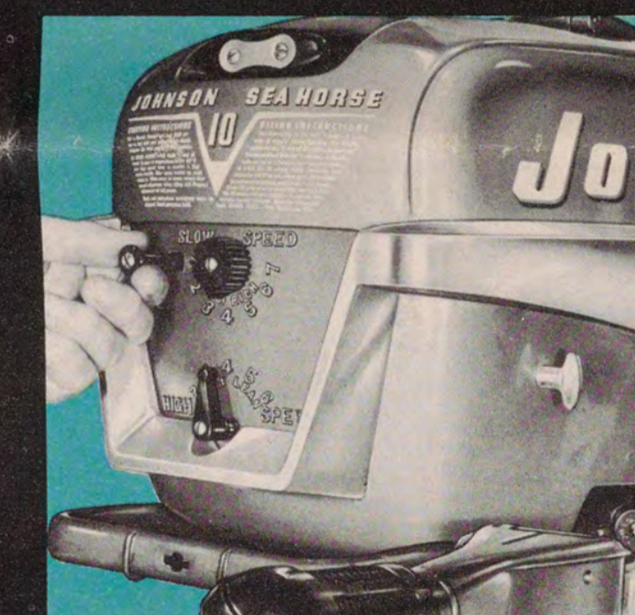

AUTOMOTIVE TYPE CHOKE

Now all Sea-Horses are built with this highly efficient automotive type choke for further refinement of Johnson's sure and easy starting. No flooding.

Face forward and drive, one-handed, with Twist-Grip Speed Control.



SYNCHRO TWIST-GRIP SPEED CONTROL

Just twist the grip to go fast, go slow, stop. Gas and spark are synchronized, automatically maintaining a correct setting between the two. Highest efficiency is assured, from slow troll to top speed. On Sea-Horses 5 1/2, 10, 25.

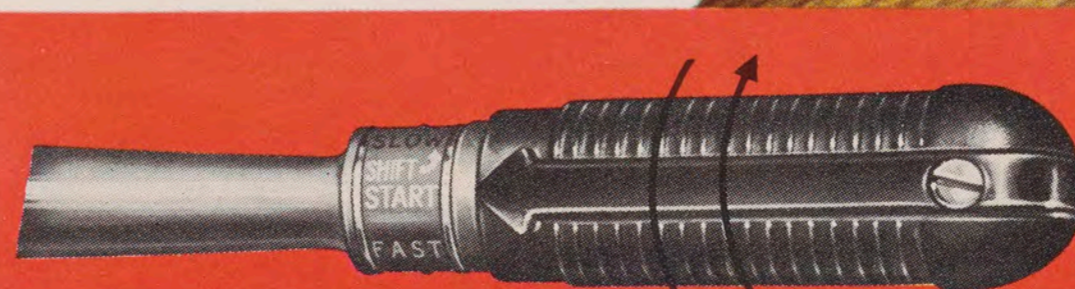

SHIP-MASTER REMOTE CONTROL. Engineered for Sea-Horse 10 and both Sea-Horse 25's. Special connectors for shift, speed and steering hook into built-in fittings on motor in seconds! Detach as quickly. Smooth, positive action gives you remote control. Two models—for single or twin-engine installations. Optional cable lengths—17 ft.



4-GAL. MILE-MASTER FUEL SYSTEM. Designed for new Sea-Horse 5 1/2—to give extraordinary cruising range. Carries separately. Flexible 6-ft., pinch-proof, 2-way fuel and pressure line plugs into motor with self-sealing connector. No spill-over! Positive automatic flow of fuel. Big fuel gauge. Interchangeable with 6-gal. Mile-Master.



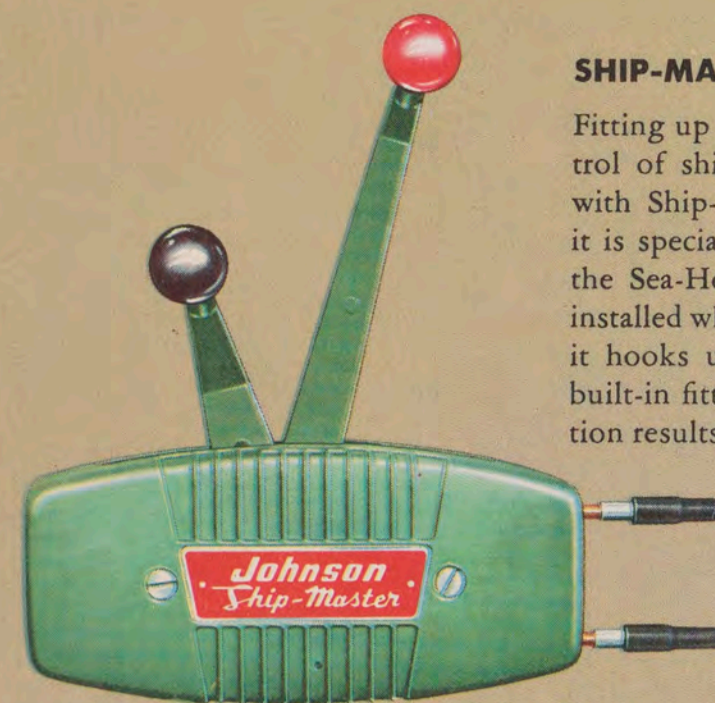

SHIP-MASTER REMOTE CONTROL

Fitting up an outboard cruiser for remote control of shift and throttle is vastly simplified with Ship-Master. It's a complete unit—and it is specially engineered for the operation of the Sea-Horse 10 and both 25's. Once it is installed where you want it (a simple procedure) it hooks up or detaches in seconds—to the built-in fittings on your motor. Perfect operation results. And it is *corrosion proof*.

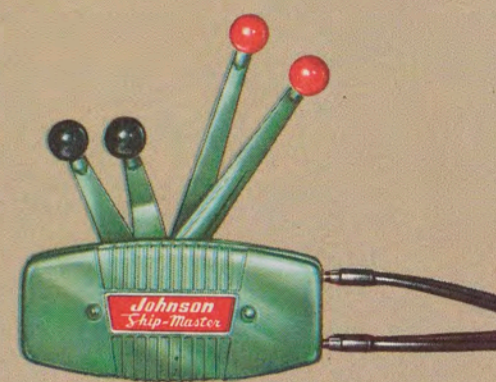

Above: Unit for single engine . . . At right: Unit for twin engine installation . . . Optional cable lengths to 17 feet.



MILE-MASTER FUEL SYSTEM

Mile-Master solves your fuel supply problem in one neat package. It's a complete fuel system—with big capacity (6 gallons), dial type fuel gauge, positive feed, automatically maintained by motor's crankcase compression, and 12 ft. fuel-and-pressure flexible line that lets you stow tank conveniently. Plugs into motor like an electric toaster with self-sealing connector that never permits leak or spill. Instant interchangeability makes it practical to carry more than one Mile-Master for extended cruising.

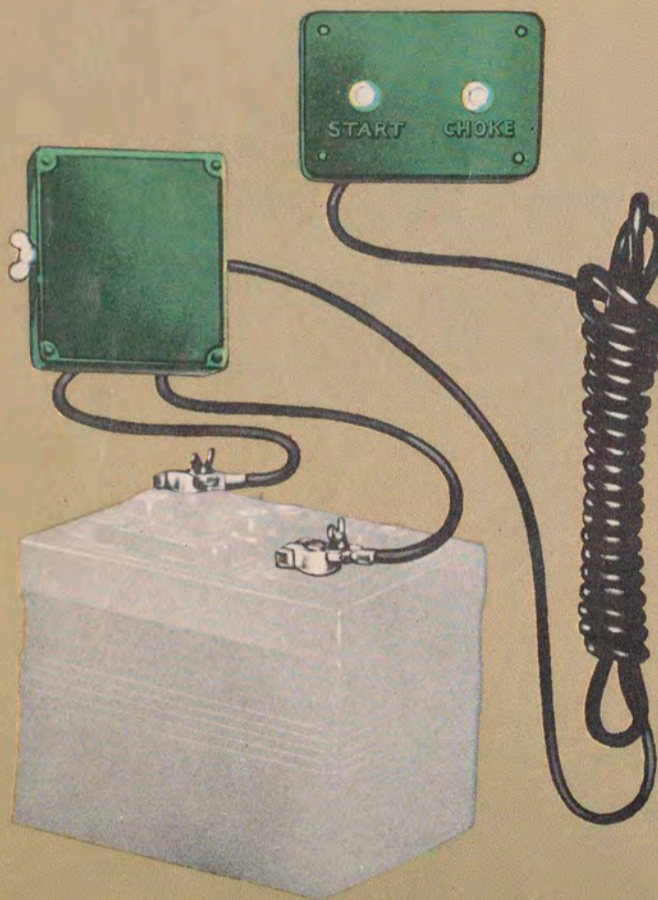
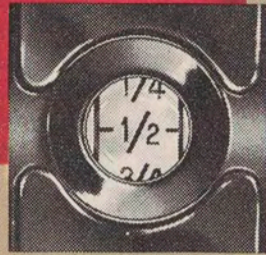

ELECTRIC STARTING

For the ultimate touch of ease and comfort in outboard runabouts and cruisers. It's sure—it's dependable—it's Johnson engineered. Choke and Starter Buttons on dash panel activate relays in control box which operate solenoid choke and Bendix Drive Electric Starter. Has automatic cut-out to insure starting at safe engine speeds. Standard equipment on Electric Starting Sea-Horse 25 (battery not included). Conventional choking and Ready-Pull Starting are retained.

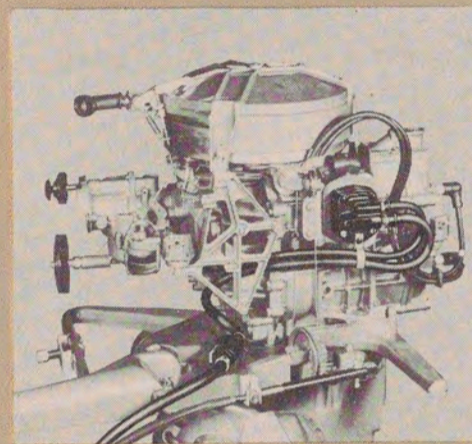

FUEL-MASTER SUPPLY SYSTEM

Here's good news for the owner of the Sea-Horse 25 who requires extra large fuel capacity and installs his own tanks and copper tubing. The Johnson Fuel-Master Supply System provides the means of hooking up easily, perfectly. Package consists of diaphragm operated Fuel Pump, over-size Filter Bowl with mounting flange, Priming Unit, Connector, Hose and Fittings. Connector plugs into motor like Mile-Master connector. Adaptable to single and twin-engine installations—and can be used with one or more tanks.

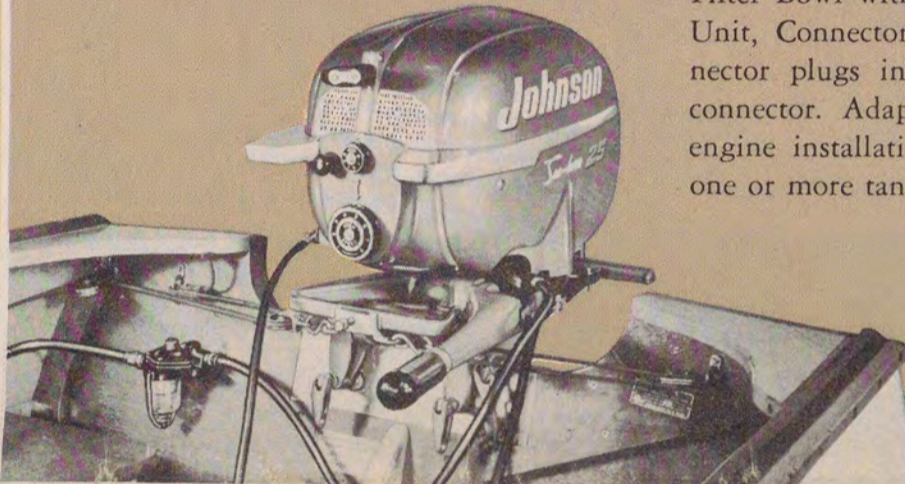

THERE'S SERVICE FOR YOUR
Sea-horse
WHEREVER YOU GO!

Cruise where you will, you're never far from a friendly Johnson dealer who has the parts and the training to give you expert service. In the United States alone, over 2,000 Dealers, backed by over 700 Master Service Stations with factory trained mechanics, stand ready to give you immediate help should the need arise.

This chain of service extends not only across the length and breadth of this continent, but around the entire world. *Wherever* you go, Johnson Sea-Horse is a familiar name. When you drive a Sea-Horse you're always among friends.

JOHNSON MOTORS • WAUKEGAN, ILLINOIS



Johnson has the features that spell Quality to big-boat skippers!

With the development of Johnson's sensational high power motors, outboard boating has broadened beyond belief. Boating enthusiasts have found a new type of power boating that combines speed and load carrying capacity with outboard simplicity, flexibility and economy. Whether *your* interest is in sport, fast runabouts, big-water fishing hulls, cruisers or work boats, you have special requirements in controls, fuel supply, starting and motor operation itself. You'll find that your requirements have been anticipated in the special, high quality features which Johnson has developed for big boat operation.



SPEAKING OF JOHNSON'S FAMOUS DEPENDABILITY!

Johnson is the first manufacturer to build 1,000,000 outboard motors.

Each one proudly bears the Johnson name.

As the millionth motor rolled off the lines, a search was instituted to determine the vintage of the oldest Johnsons still in existence.

The results were incredible!

The fifty oldest motors reported were all built in the first three months of

Johnson production! All 31 years old! All verified!

The very *first* Johnson sold is still in use. It is shown here with its present owner, LeRoy C. Lynch of Madison, Wisconsin, who bought it from a previous owner two years ago.

Johnson's always have been and always will be built for ruggedness and long life. They are noted for **DEPENDABILITY**—because they *are* dependable.

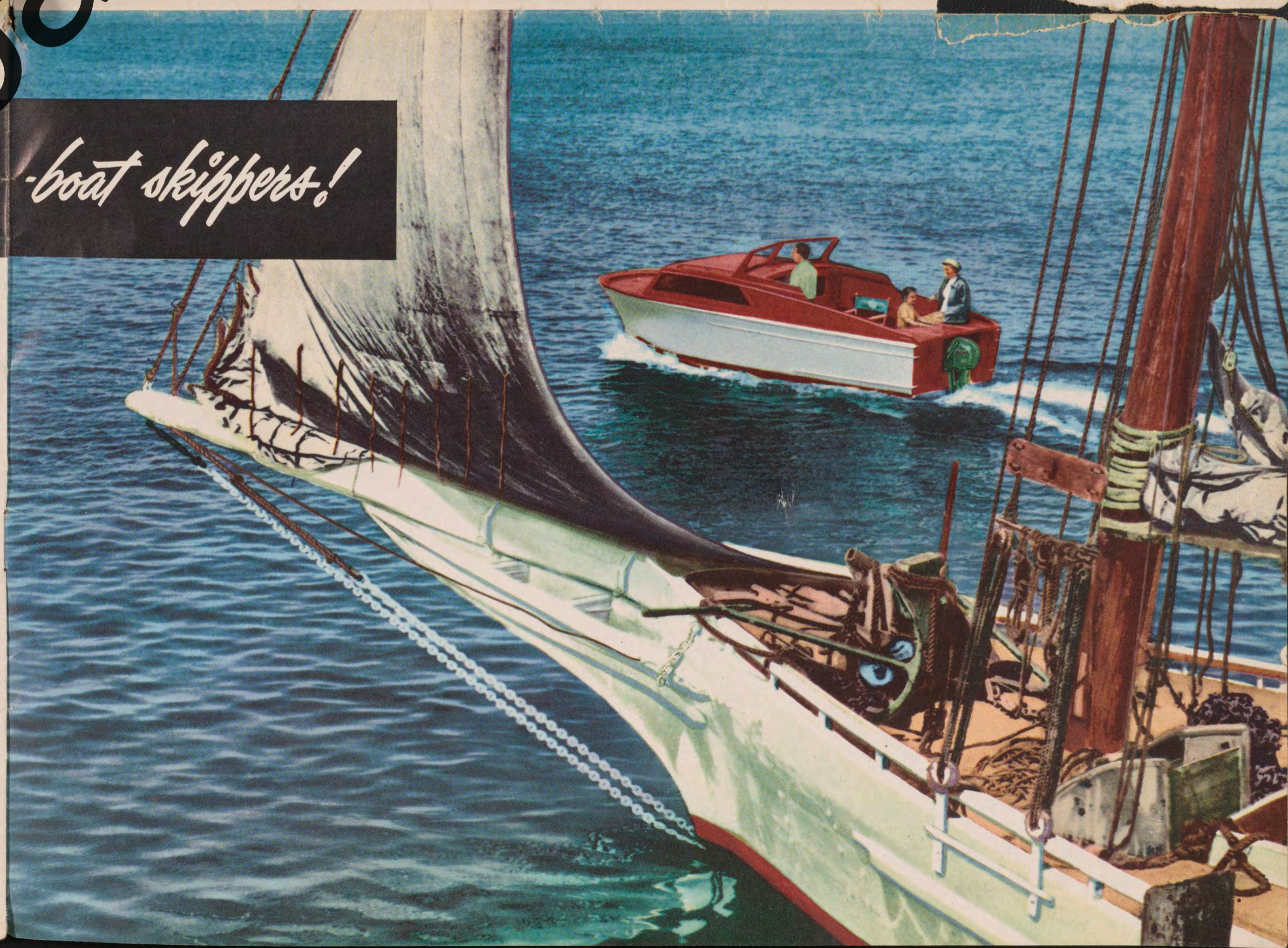

Antique Boat Museum

HANDY CHART OF SPECIFICATIONS...1954 JOHNSON SEA-HORSE OUTBOARD MOTORS

	SEA-HORSE 25	Electric Starting SEA-HORSE 25	SEA-HORSE 10	SEA-HORSE 5½	SEA-HORSE 3
OBC CERTIFIED BRAKE H.P.*	25 horsepower	25 horsepower	10 horsepower	5½ horsepower	3 horsepower
WEIGHT	99 lbs. (Long model, 101 lbs.) Mile-Master Fuel Tank, 13 lbs.	111 lbs. (Long model, 113 lbs.) Mile-Master Fuel Tank, 13 lbs.	63 lbs. (Long model, 64½ lbs.) Mile-Master Fuel Tank, 13 lbs.	47 lbs. (Long model, 48 lbs.) Mile-Master Fuel Tank, 10 lbs.	32 lbs. (Long model, 32½ lbs.)
LENGTH	46½" (Long model, 51½")	46½" (Long model, 51½")	42½" (Long model, 47½")	39½" (Long model, 44½")	37½" (Long model, 42½")
WIDTH	12½"	12½"	11½"	10½"	9¾"
STERN HEIGHT	15" (Long model, 20")	15" (Long model, 20")	15" (Long model, 20")	15" (Long model, 20")	15" (Long model, 20")
PROPELLER	3-blade rubber-floated aluminum, 10¾" diameter, 12½" pitch	3-blade rubber-floated aluminum, 10¾" diameter, 12½" pitch	3-blade rubber-floated aluminum, 9" diameter, 8" pitch	2-blade aluminum brass bushed, weedless design. 8" dia., 7¼" pitch	3-blade aluminum brass bushed, weedless design. 6½" dia., 5¾" pitch
BORE AND STROKE	Bore, 2⅞"; Stroke, 2¾"	Bore, 2⅞"; Stroke, 2¾"	Bore, 2⅞"; Stroke, 1⅞"	Bore, 1⅞"; Stroke, 1½"	Bore, 1⅞"; Stroke, 1⅞"
PISTON DISPLACEMENT	35.7 cubic inches	35.7 cubic inches	16.6 cubic inches	8.84 cubic inches	5.28 cubic inches
GEAR REDUCTIONS	12 to 21	12 to 21	12 to 21	12 to 21	12 to 20
MOTOR REVOLUTION	4000-5000 per minute	4000-5000 per minute	4000-5000 per minute	3500-4500 per minute	3500-4500 per minute
FUEL CAPACITY	Separate 6-gallon Mile-Master Fuel Tank	Separate 6-gallon Mile-Master Fuel Tank	Separate 6-gallon Mile-Master Fuel Tank	Separate 4-gallon Mile-Master Fuel Tank	4.88 pints
DRIVE	Gear Shift—Neutral-Fwd.-Rev.	Gear Shift—Neutral-Fwd.-Rev.	Gear Shift—Neutral-Fwd.-Rev.	Gear Shift—Neutral-Fwd.-Rev.	Full Pivot Reverse
REMOTE CONTROL FITTINGS	Yes	Yes	No	No	No
SPEED CONTROL	Twist Grip on the steering handle synchronizes spark and throttle	Twist Grip on the steering handle synchronizes spark and throttle	Twist Grip on the steering handle synchronizes spark and throttle	Twist Grip on the steering handle synchronizes spark and throttle	Spark and throttle are synchro- nized in one lever
SPEED RANGE, AVERAGE	Slow trolling to over 30 MPH	Slow trolling to over 30 MPH	Slow trolling to over 20 MPH	Slow trolling to over 12 MPH	Slow trolling to over 8½ MPH
BOATS	Large outboard boats. Fast run- abouts. Cruisers. Auxiliary power	Large outboard boats. Fast run- abouts. Cruisers. Auxiliary power	Large outboard boats. Fast run- abouts. Cruisers. Auxiliary power	Outboard boats. Large canoes. Dinghies. Auxiliary power	Outboard boats. Any canoe. Dinghies

FEATURES **ENGINE TYPE:** All models are Johnson Perfected Alternate Firing Twins. **STARTING:** Automatic rewind Ready-Pull Starter in all models. Oversize Starting Drum in the Sea-Horse 25's for easy pull. Automotive-type choke in all models—no flooding. **CARBURETION:** Full-range carburetion in all models—correct amount of fuel at all speeds; flow of fuel automatically regulated by low and high speed jets. **IGNITION:** All models have Hi-Power, waterproof, easily adjusted magneto with 2 coils, 2 condensers, 2 automotive-type breakers. Platinum points on Sea-Horses 25 and E. S. 25. All models have water-proof rubber Spark Plug Shields. **SILENCING:** Carburetor intake silencers on Sea-Horses 3, 5½, and 10; exhaust relief silencers on 5½. **PROPELLER PROTECTION:** Spring Release Shock Absorber Drive in Sea-Horse 5½. Rubber floated propeller with pilot, and shear pin protection in all other models. **STEERING:** Vibrationless, with automatic Co-Pilot, all models. **FUEL PROTECTION:** All models have fuel strainer and filter. In Sea-Horse 5½, 10, 25 and E. S. 25, fuel is filtered and strained as it leaves Mile-Master Fuel Tank. **COOLING:** Vari-Volume Pump, all models. **AUTOMATIC SPEED LIMITATION:** On Sea-Horse 25 and E. S. 25. Prevents racing motor in neutral; unlimited in forward and reverse. **VERTICAL ADJUSTMENT:** Quick-Set Thrust Socket for instant correct vertical adjustment on Sea-Horses 3, 5½, 25 and E. S. 25. **ENGINE ACCESSIBILITY:** Up-and-Off Motor Hood on Sea-Horses 5½ and 10. **LUBRICANT SEALS:** Drive shaft and propeller shaft, all models. Aircraft-type main bearing seals on Sea-Horses 10, 25, and E. S. 25. **LUBRICATION:** Automatic, all models. Engine parts lubricated by oil in fuel mixture. **EXHAUST DISCHARGE:** All models have quiet underwater exhaust. **ANTI-CORROSION:** All models have 3-way protection against corrosion plus stainless steel propeller shaft, drive shaft and underwater screws.

MATERIALS **GEARS:** Hardened steel operating in hypoid oil for most efficient lubrication, all models. **CYLINDER BLOCK:** Lightweight aluminum with wear-resistant cast-in iron sleeves. Removable head. **PISTONS:** Lightweight aluminum. Aircraft quality piston rings, all models. **CRANKSHAFT:** Drop-forged nickel molybdenum steel. Integrally counterbalanced. **CONNECTING RODS:** Silver-faced forged steel with needle bearings on Sea-Horse 10. Forged steel with retained needle bearings on Sea-Horses 25 and E. S. 25. Full floating wrist pin on Sea-Horses 10, 25 and E. S. 25. Sea-Horses 3 and 5½—aluminum alloy with

bronze bearing surfaces. **BEARINGS:** Hard bronze low friction bearings in Sea-Horses 3 and 5½. Needle bearings on end journals of Sea-Horse 10 crankshaft. Tapered, ball and needle bearings in Sea-Horses 25 and E. S. 25.



*All ratings are OBC certified brake horsepower at 4000 rpm.

Johnson Motors reserves the right to change construction, materials, or specifications without notice and without obligation. All weights are approximate.

JOHNSON MOTORS, WAUKEGAN, ILLINOIS

BILL'S MOTORCYCLE SHOP
1005 SO. STATE ST.,
SYRACUSE, N. Y.