

From the first Mercury, produced just 15 short years ago, to the brilliant 1954 Mercury line there's a consistent record of engineering and design "firsts" that have sparked the entire outboard industry — and earned for Mercury the undisputed position of outboard leadership!

See the 15th Anniversary Line and learn why the combination of speed, power and endurance is unmatched by any other outboards. Again, Mercury outboard motors mean the most compact power packages per pound of weight you'll find in the whole field . . . performance and rugged reliability that has made Mercury the "most wanted" outboard in America!

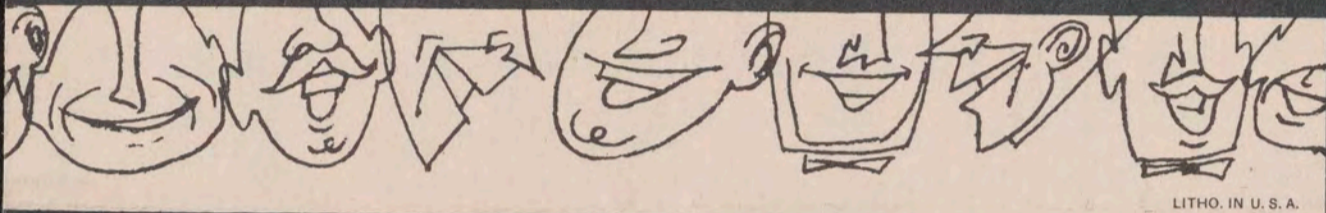

LITHO. IN U.S.A.

KIEKHAEFER

VANGUARD ENGINEERING

PACKS A LIFETIME

OF PROGRESS

INTO 15

PACE-SETTING YEARS

## Here's what they say about **MERCURY**

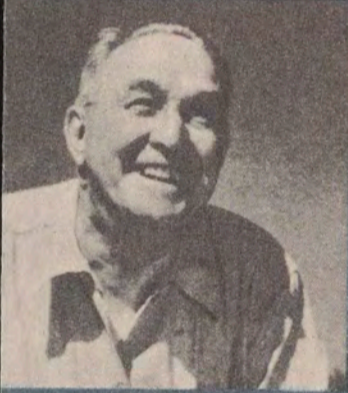

### Inventor of the FIRST Outboard CAMERON B. WATERMAN:

"I invented the outboard motor in 1905 because I loved to fish and hated to row. Other fishermen felt the same way and we produced and sold several thousand Watermans before another manufacturer entered the field in 1909.

Mercury is my choice in outboards today. They are outstanding examples of the finest modern outboard design and craftsmanship. What a far cry from my little 'one lung' of 1905."



### World Traveler, Lecturer and Photographer JULIAN GROMER:

"For fun, enjoyment and adventure, it's hard to beat an outboard cruiser trip. I chose Mercury for mine, for an outboard with plenty of 'get-up-and-go', built to stand a rough 70-mile ocean trip. Mercury 'safety engineering' offers bonus values in speed, power, stamina and reliability!"



### Florida Fishing Guides FRANKEE AND JIMMIE ALBRIGHT:

"Our fishing jaunts cover a lot of salt water—over crusty coral and oyster beds, weedy flats and choppy open seas. Naturally, we can't settle for less than fast, reliable water transportation . . . and that means Mercury—for performance instead of promises!"

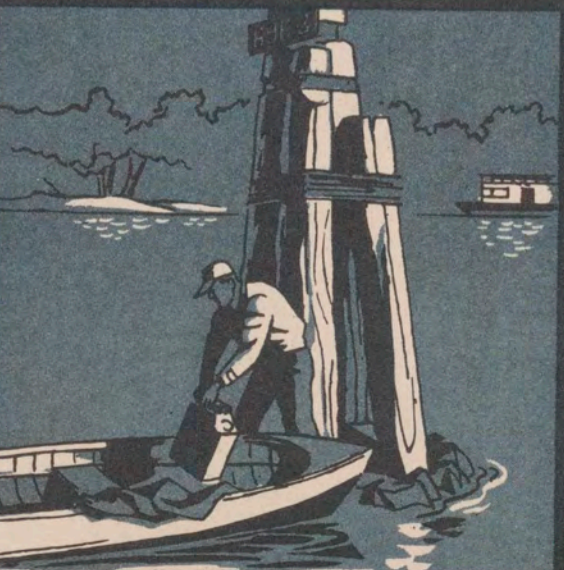

### Work Boat Operator CHARLES HASTINGS:

"It isn't the glamour of outboards that counts with me . . . it's the way they stand up to the daily strain of tough work! And for power, endurance and sheer lugging ability, I'll stack Mercury against any competition! I know that the Kiekhaefer engineering that goes into Mercurys is responsible for the performance you get out of 'em!"

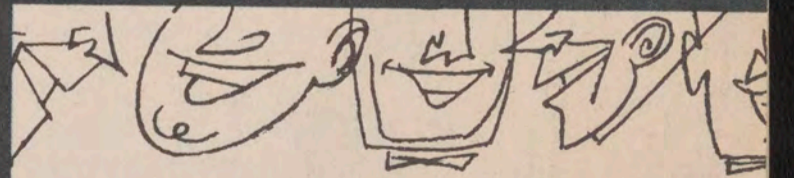

KIEKHAEFER  
**MERCURY**

15th  
Anniversary  
Line



a Lifetime of  
Outboard Progress  
packed into

15 Fabulous Years

Just as the first Mercury sparked advances that made all outboards better, so the 1954 Mercurys continue to set the highest standards in the industry... with proved, superior Kiekhaefer design, engineering and performance features that make Mercury the "most wanted" outboard in America today!

See the magnificent Mercury 15th Anniversary models at your dealer's now... he's listed in the yellow pages of your telephone book. Ask him for a demonstration of America's finest outboards—Mercury!

**FULL JEWELED POWER** — anti-friction ball and roller bearings throughout — first in Mercury, in every Mercury!

**KIEKHAEFER CORPORATION, Fond du Lac, Wisconsin** © 1954

Write for FREE illustrated catalog: "America's Finest Outboards". Features of Mercury motors are protected by issued or pending patents.



Proved favorite of fishermen everywhere

**MERCURY mark 5**

Alternate Twin with Push-Button Clutch! 5 s.a.e.\* H.P.

It's light — only 40 pounds, easy to handle pounds. Sensational Push-Button Clutch for finger-touch starts and stops. Full Reverse with exclusive Rear Steering Handle... Dual Purpose Drive for real weedless operation... adjusts instantly for efficient, straight line thrust in open water. Multiple Disc Propeller Clutch... safe, sure propeller protection. Unequalled power and stamina... smooth, quiet all-day trolling.

Ready — Rugged — Reliable!

**MERCURY mark 7**

Alternate Twin with Rocket Engine! 7.5 s.a.e.\* H.P.

Whatever the weather, in salt water or fresh, the Mercury Mark 7 is the proved standard of its class. Plenty of power for bigger fishing boats with a smooth, steady all-day troll. All the famous Mercury features — Full Jeweled Power, Unicast one-piece gear case — Full feathered safety steering — Forged steel connecting rods — waterproofed spark plugs, Duo-flex propeller clutch and many more.

Sleek, Trim Powerhouse

**MERCURY mark 20**

Alternate Twin with Reverse Gear and Neutral, Remote Fuel Tank 16 s.a.e.\* H.P.

Big engine performance in a light, compact, easy-to-handle package. A high-spirited beauty with a Hurricane of power for water sports, light cruisers, large family runabouts and work boats. A real, all-purpose outboard capable of pulse-quickening top speed and silky smooth, quiet, all-day trolling. Engineered for years of rugged duty.

Forward, neutral and reverse... Twist-grip synchronized spark and throttle... designed for quickly detachable remote controls, plus all the exclusive performance proved Mercury features make this "America's Most Wanted Outboard"



Mercury remote fuel tank. Furnished as standard equipment with Mark 20 and Mark 50.

\*s.a.e. horsepower ratings used for Mercury motors are based on the standard definition of horsepower as accepted by the Society of Automotive Engineers: a unit of power numerically equal to a rate of 33,000 foot-pounds of work per minute.

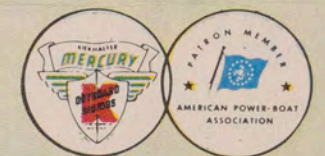

Here at last, all the features you ever wanted in a big outboard engine!

- Easiest starting of any large outboard because of exclusive 4-cylinder in line construction... a ten-year old can start it.
- Integrated remote control design arranged for inside or outside steering.
- Sealed under-cowl... maximum protection against spray and following seas.
- New Cowl-Around lifting and carrying handle.
- New smart, compact, modern Mercury styling.
- The famous Thunderbolt engine for super-smooth power flow... from a slow, steady troll to record racing speeds.
- New "Hi-Thrust" lower unit, geared for power efficiency with heavy loads.
- Plus "Full Jeweled Power" and all the exclusive pace-setting Mercury features.

Introducing today's most powerful outboard

New **MERCURY mark 50**

4-CYLINDER IN LINE, ALTERNATE FIRING FORWARD, NEUTRAL AND REVERSE 40 s.a.e.\* H.P.

Power!!! Power!!! Power!!! For big outboard cruisers, big, fast family runabouts, heavy commercial fishing boats, the whole family on water skis... the mighty Mark 50's great reserve of fighting horsepower masters any outboard application with effortless ease.





MARK 50  
40 s.a.e. H.P.

today's most powerful outboard

## NEW MARK 50

Introducing the magnificent



15th  
Anniversary  
Line

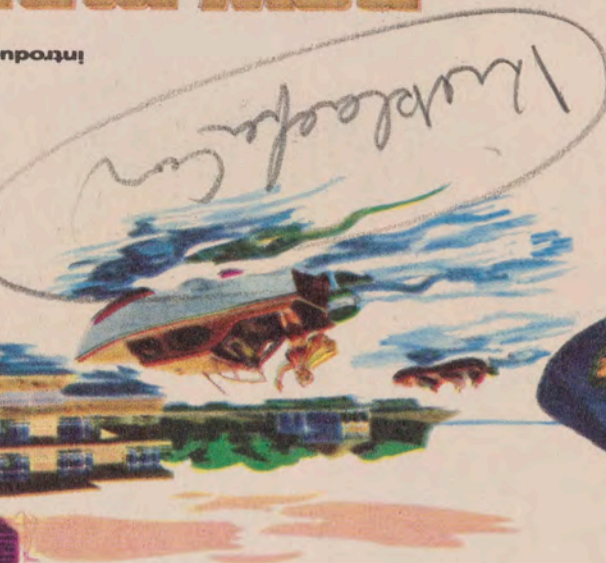

Mercury  
America's Finest Outboards

move up

... TO

ENGINEERING

THAT'S ALWAYS

"YEARS AHEAD"

Today's Mercury is the culmination of 15 years of progressive Mercury engineering and the finest outboard technology in the industry — skilled craftsmen, scientists, engineers and machines working constantly to maintain and increase Mercury's leadership.

It's pioneering Kiekhaefer engineering that has given today's sportsman finer outboards than ever . . . that keeps Mercury head and shoulders above the rest — truly America's finest outboards!

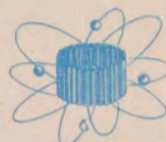

**FULL JEWELLED POWER**—the big "plus" in every Mercury! Ball and roller bearings applied to all moving parts — crankshaft, connecting rods, drive and propeller shafts — for smooth power flow, minimum power loss, less starting effort, greater engine efficiency, more horsepower delivered to the propeller, better engine performance and longer engine life. A Mercury "exclusive".

**WATERPROOF MAGNETO**—fully enclosed, completely protected from moisture and salt air, functions normally even when completely submerged — so your Mercury shrugs off rain and bad weather, starts easily every time. High voltage at starting speeds gives those famous Mercury quick starts. Aircraft type breakers. Patents pending.

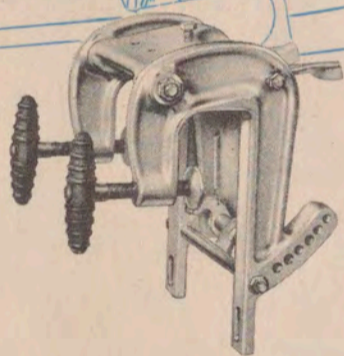
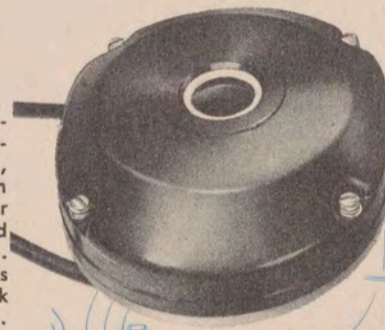

**DROP FORGED ALUMINUM CLAMP AND SWIVEL BRACKETS** — a Mercury "first". Unbreakable, heat treated to the strength of steel yet light in weight. Deep-throated for transom safety; equipped with fine thread rubber-handled clamp screws. Patents pending.

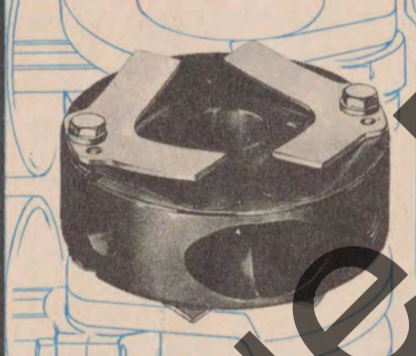

**VARI-TIMED VALVES** — still another Mercury "first", patented and a feature of every Mercury. Provides automatically correct valve timing at all operating speeds — from a purring troll to wide-open racing pace. Perfect sealing of crankcase means easier starting, simplified carburetor adjustments. Eliminates manifolds and the need for dual carburetion and induction systems. Backfire-proof for extra safety.

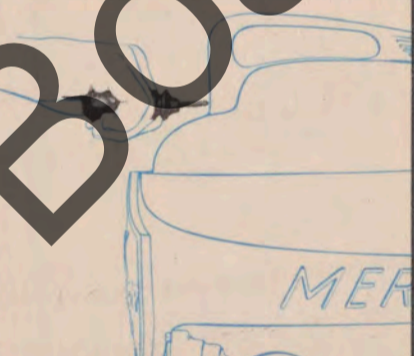

**MAGNA-PUL STARTER**—a patent-protected feature of all Mercury outboard motors. Operates on a simple magnetic principle . . . eliminates need for delicate springs or fragile stamped parts. Rugged and safe—with no loose pieces on revolving flywheel. Drop forged steel pawls for a lifetime of those famous fast Mercury starts.

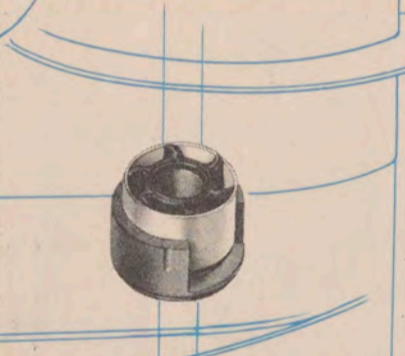

**VARIABLE VOLUME ROTAX WATER PUMP**—for superior cooling at all speeds, from slowest troll to wide-open racing pace. Operates as a positive displacement pump at low speeds and a centrifugal pump at high speeds . . . weed-proof, silt-proof, non-clogging — and easily accessible. Patented.

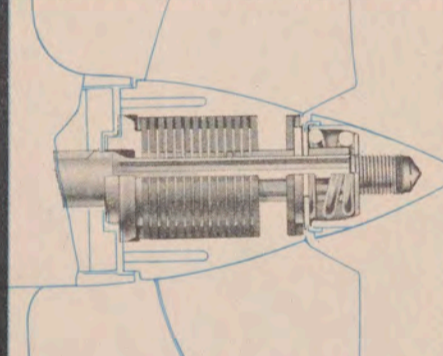

**MULTIPLE DISC SAFETY CLUTCH** — provides improved propeller protection for the Mark 5, with patents pending. Propeller driven through splines on shaft rather than shear pins. Clutch power is partly dependent on propeller thrust, is reduced at lower speeds to protect propeller in negotiating obstructions. Damaged propeller will function with half the blades gone.



**FLO-TORQ PROPELLER DRIVE** — Compressed live rubber bushing cushions normal loads, slips on impact to protect propeller. Shear pins are eliminated. Standard equipment on Mark 20 and Mark 50. Mercurys are built to get you there — and back!

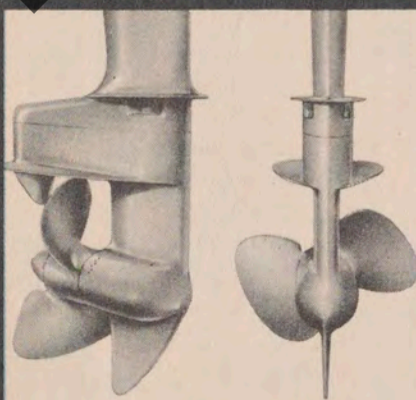

**UNI-CAST ONE-PIECE GEAR HOUSING** — offers extra strength with one-piece drive shaft housing. Hydrodynamically correct design decreases frontal area to yield more speed per horsepower. Shafts, bearings and gears permanently aligned. No need for frequent grease checks, no gaskets to leak or soften. On all models, patents pending.

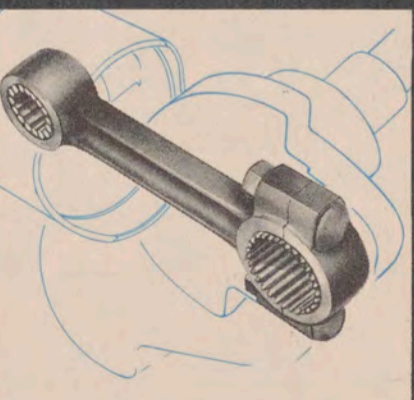

**"HI-REV" MICRO-MOUNTED DROP FORGED ALLOY STEEL CONNECTING RODS**—of chrome nickel-moly steel, heat treated, hardened and tempered, precision ground to close tolerances, balanced for matched performance and doweled into position with ground bolts. Provides peak efficiency where power originates . . . roller bearings on crank pins and wrist pins reduce friction.

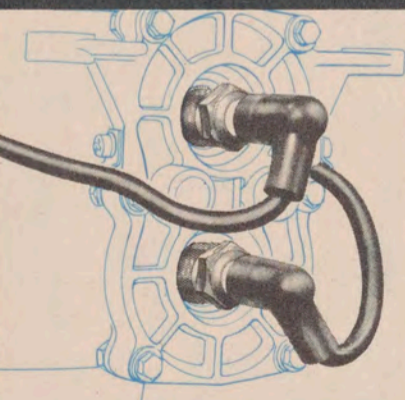

**WATERPROOFED SPARK PLUGS** — for all-weather operation in fresh or salt water. Stay dry and clean, fire even when completely submerged. Contribute to Mercury's quick starts, improved performance and minimum maintenance. Weather-protected receptacle for spare plugs under cowl.

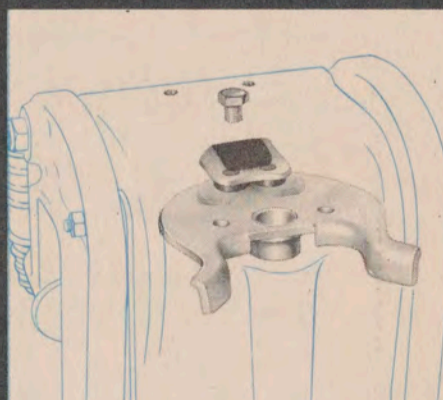

**MULTIPLE DISC CO-PILOT** — another Mercury "first", protected by pending patents. Spring-loaded co-pilot makes possible smooth manual control plus automatic steering that frees your hands when your course is set and clear ahead. Live rubber bushing cushions power unit . . . absorbs vibrations.